

Biomedical Engineering for Africa

Edited by Tania S. Douglas

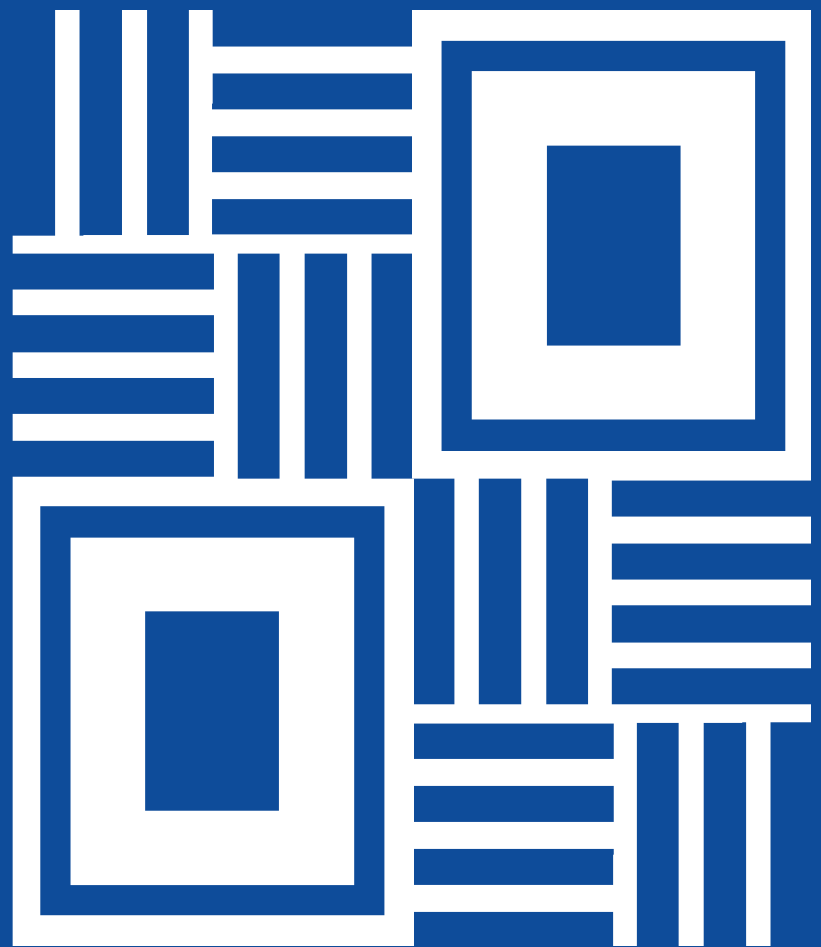

Biomedical Engineering for Africa

This work is licenced under the Creative Commons license:



© The Authors

Published in 2019 by University of Cape Town Libraries, Rondebosch, Cape Town, 7700, South Africa.

Suggested citation: Douglas, T.S. Ed. 2019. *Biomedical engineering for Africa*. Cape Town: University of Cape Town Libraries. DOI: <http://dx.doi.org/10.15641/0-7992-2544-0>

Suggested citation of a chapter: Makobore, P.N. & Mulerwa, M. 2019. An electronically controlled gravity feed infusion set for intravenous fluids. In *Biomedical engineering for Africa*. T.S. Douglas, Ed. Cape Town: University of Cape Town Libraries. 125–138. DOI: <http://dx.doi.org/10.15641/0-7992-2544-0>

ISBN: 978-0-7992-2544-0

Contents

List of Contributors	v
Peer Review Statement	ix
Foreword <i>Folasade T. Ogunsola</i>	x
Chapter 1. Introduction <i>T.S. Douglas and R.L. Murphy</i>	1
Part 1. African Perspectives on Biomedical Engineering	5
Chapter 2. The Case for Biomedical Engineers in African Hospitals: A Clinician's Point of View <i>D. Atwine</i>	7
Chapter 3. Recent Developments in Biomedical Engineering Education in Africa: A Focus on Nigeria and the University of Ibadan <i>A. Coker, F. Akintayo, C. Achi, M. Odeniyi, A. Olorunnisola and D. Akano</i>	11
Chapter 4. Creating a Department of Biomedical Engineering and an Undergraduate Programme – The University of Lagos Experience <i>O.P. Popoola, N.K. Iurhe, O.J. Balogun and A.A. Osuntoki</i>	19
Chapter 5. Biomedical Engineering in Ethiopia <i>A. Hussein and D. Assefa</i>	27
Part 2. From Needs to Products	33
Chapter 6. Biomedical Engineering and Entrepreneurship <i>C.J. Diji, A.I. Shittu, O. Dakare, N. Idusuyi and F. Isaacs</i>	35
Chapter 7. Problem Identification and Needs Assessment for Healthcare Technologies <i>T. Saidi, O.O.E. Ajibola, A. Desmennu, B.R. Ojebuyi, O.A. Oladapo, O. Tade, C.G. Achi, O.J. Balogun, S.C. Nwaneri, A.I. Aiyegbusi, D.C. Umesei, A.B. James, A.O. Coker and C.J. Achenbach</i>	41
Chapter 8. Frugal Biodesign: An Approach for Developing Appropriate Medical Devices in Low Resource Settings <i>S. Sivarasu</i>	47
Chapter 9. Materials for Medical Services <i>T. Saidi, A.A. Dare, S.K. Fasogbon, O. Ewemoje, O. Anyaeche, M. Bolarinwa, O. Adetoyi, K. Adewole, O. Lawal and A.O. Coker</i>	55
Part 3. Design Case Studies	63
Chapter 10. User-Centred Design in a Health Innovation Course to Address Hearing Loss in the Elderly <i>N. Conrad, T.E.M. Mutsvangwa, A. Doyle, T. Saidi and T.S. Douglas</i>	65

Chapter 11. Implementing a Design Methodology: Concept for a Head Positioning Device for Hospital Beds	77
<i>O.P. Popoola, O.J. Balogun, N. Irurhe, O. Adesogan, K.K. Adewole, S.K. Fasogbon, E. Wessels, G. Beukes and S. Sivarasu</i>	
Chapter 12. Medical Device Concept for Burn Wound Exudate Detection	91
<i>K. Burke, A. Dai, J. Hauck, M. Glucksberg and A.I. Michael</i>	
Chapter 13. Infant Warming Device for Neonatal Surgery in a Low-Resource Setting	103
<i>A.O. Coker, T. Lawal, C. Achi, D. Akano, A.O. Olorunnisola, L. Cilenti, Y.H. Lee, M. Simkowski, F. Cummins, M. Doerfler, E. Glowik, R. Lu, A. Williams, M. Chua, I. Ikene, S. Das, D. Gatchell, M. Glucksberg and R.L. Murphy</i>	
Chapter 14. Needle Disposal Device for Use in Low-Resource Settings	111
<i>G. Beukes, C. Achi, B. Bolasodun, A. Desmennu, A. Oloyo, O. Oyebola, O. Oyewola, T. Saidi, A.O. Coker and S. Sivarasu</i>	
Chapter 15. An Electronically Controlled Gravity Feed Infusion Set for Intravenous Fluids	125
<i>P.N. Makobore and M. Mulerwa</i>	
Chapter 16. A Prototype Metabolic Cage for Rats and Mice for Biomedical Research in Nigeria	139
<i>O.A. Adejumbi, C.J. Diji, M.K.C. Sridhar, A.O. Coker, N. Idusuyi, C.G. Achi, O.O. Omotosho, T.O. Omobowale and A.O. Olorunnisola</i>	
Part 4. Ethical, Legal and Regulatory Considerations for Biomedical Engineers	147
Chapter 17. Biomedical Engineering Ethics	149
<i>O. Ewaleifoh, O. Adeleye, A.O. Balogun, S.O. Adetona, K.O. Soetan, S.O. Adeosun and A.A. Osuntoki</i>	
Chapter 18. Intellectual Property Protection and Commercialisation	161
<i>Y. Karanja and R.L. Murphy</i>	
Chapter 19. Medical Device Regulation in Africa	175
<i>T. Saidi and T.S. Douglas</i>	
Part 5. Situating Biomedical Engineering Within the Health System	187
Chapter 20. Healthcare Technology Management	189
<i>A.K. Oloyo, S. Nwaneri, S. Gbenle, F. Ipinnimo, C. Mutswangwa and A.A. Osuntoki</i>	
Chapter 21. Healthcare Technology Management in Zimbabwe	195
<i>C. Chimhundu</i>	
Chapter 22. Mobile Health for Africa	203
<i>B. Malila, T.E.M. Mutsvangwa and T.S. Douglas</i>	

List of Contributors

Editor

Douglas, Tania S. Division of Biomedical Engineering, University of Cape Town, South Africa

Editorial Committee

Coker, Akinwale O. Department of Civil Engineering, University of Ibadan, Nigeria

Gatchell, David W. Segal Design Institute, Northwestern University, Evanston, IL, United States of America

Glucksberg, Matthew R. Department of Biomedical Engineering, Northwestern University, Evanston, IL, United States of America

Murphy, Robert Leo. Center for Global Health, Northwestern University, Chicago, IL, United States of America

Osuntoki, Akinniyi A. Department of Biochemistry, University of Lagos, Nigeria

Palamountain, Kara. Kellogg School of Management, Northwestern University, Evanston, IL, United States of America

Authors

Achenbach, Chad J. Department of Medicine and Center for Global Health, Northwestern University, Chicago, IL, United States of America

Achi, Chibueze, G. Department of Civil Engineering, University of Ibadan, Nigeria

Adejumobi, Olumuyiwa A. Department of Veterinary Medicine, University of Ibadan, Nigeria

Adeleye, Olurotimi. Department of Systems Engineering, University of Lagos, Nigeria

Adeosun, Samson. Department of Metallurgical and Materials Engineering, University of Lagos, Nigeria

Adesogan, Olufemi. Department of Civil Engineering, University of Ibadan, Nigeria

Adetona, Sunday. Department of Electrical and Electronics Engineering, University of Lagos, Nigeria

Adetoyi, Oluyemi. Department of Electrical and Electronic Engineering, University of Ibadan, Nigeria

Adewole, Kazeem. Department of Civil Engineering, University of Ibadan, Nigeria

Aiyegbusi, Ayoola Ibifubara. Department of Physiotherapy, University of Lagos College of Medicine, Lagos, Nigeria

Ajibola, Olawale O. E. Department of Systems Engineering, University of Lagos, Nigeria

Akano, Damola. Department of Civil Engineering, University of Ibadan, Nigeria

Akintayo, Folake O. Department of Civil Engineering, University of Ibadan, Nigeria

Anyaeche, Osita. Department of Industrial and Production Engineering, University of Ibadan, Nigeria

Atwine, Daniel. Department of Biomedical Sciences and Engineering, Mbarara University of Science and Technology, Mbarara, Uganda

Balogun, Adeola O. Department of Electrical and Electronics Engineering, University of Lagos, Nigeria

Balogun, Oluwaseyi Jessy. Department of Biomedical Engineering, University of Lagos, Nigeria

Beukes, Giancarlo. Division of Biomedical Engineering, University of Cape Town, South Africa

Bolarinwa, Mojosola. Department of Industrial and Production Engineering, University of Ibadan, Nigeria

Bolasodun, Babatunde. Department of Metallurgical and Materials Engineering, University of Lagos, Nigeria

Burke, Kelsey. Department of Biomedical Engineering, Northwestern University, Evanston, IL, United States of America

Chimhundu, Chipso. Biomedical Engineering Consultant, Harare, Zimbabwe

Cilenti, Lautaro. Segal Design Institute, Northwestern University, Evanston, IL, United States of America

Coker, Akinwale O. Department of Civil Engineering, University of Ibadan, Nigeria

Conrad, Nailah. Division of Biomedical Engineering, University of Cape Town, South Africa

Cummins, Frank. Department of Biomedical Engineering, Northwestern University, Evanston, IL, United States of America

Dai, Andrew. Department of Biomedical Engineering, Northwestern University, Evanston, IL, United States of America

Dakare, Olamitunji. Department of Business Administration, Pan-Atlantic University, Lagos, Nigeria

Dare, Ademola. Department of Mechanical Engineering, University of Ibadan, Nigeria

Das, Sanjeet. Department of Biomedical Engineering, Northwestern University, Evanston, IL, United States of America

Desmennu, Adeyimika. Department of Health Promotion and Education, University of Ibadan, Nigeria

Diji, Chukwuemeka J. Department of Mechanical Engineering, University of Ibadan, Nigeria

Doerfler, Matthew D. Feinberg School of Medicine, Northwestern University, Chicago, IL, United States of America

Douglas, Tania S. Division of Biomedical Engineering, University of Cape Town, South Africa

Doyle, Anastasia. Division of Biomedical Engineering, University of Cape Town, South Africa

Ewaleifoh, Osefame. Department of Microbiology-Immunology, Northwestern University, Chicago, IL, United States of America

Ewemoje, Oluseyi. Department of Agricultural and Environmental Engineering, University of Ibadan, Nigeria

Fasogbon, Samson K. Department of Mechanical Engineering, University of Ibadan, Nigeria

Gatchell, David. Segal Design Institute, Northwestern University, Evanston, IL, United States of America

Gbenle, Oluwasegun A. Department of Biomedical Engineering, University of Lagos, Nigeria

Glowik, Ewa. Department of Biomedical Engineering, Northwestern University, Evanston, IL, United States of America

Glucksberg, Matthew. Department of Biomedical Engineering, Evanston, IL, Northwestern University, United States of America

Haile, Dawit Assefa. Center of Biomedical Engineering, Addis Ababa University, Ethiopia

Hauck, Joshua. Department of Biomedical Engineering, Northwestern University, Evanston, IL, United States of America

Hussein, Ashenafi. Center of Biomedical Engineering, Addis Ababa University, Ethiopia

Idusuyi, Nosa. Department of Mechanical Engineering, University of Ibadan, Nigeria

Ikene, Iboro. Department of Biomedical Engineering, Northwestern University, Evanston, IL, United States of America

Ipinnimo, Femi. Department of Systems Engineering, University of Lagos, Nigeria

Irurhe, Nicholas K. Department of Radiation Biology, Radiotherapy, Radiodiagnosis & Radiography, Lagos University Teaching Hospital, Lagos, Nigeria

Isaacs, Faranha. Division of Biomedical Engineering, University of Cape Town, South Africa

James, Ayorinde Babatunde. Virology Unit, University of Lagos College of Medicine, Nigeria

Karanja, Yvonne W. Division of Biomedical Engineering, University of Cape Town, South Africa

Lawal, Oluwatoyin. Department of Oral Pathology, University of Ibadan, and Department of Oral Pathology, University College Hospital, Ibadan, Nigeria

Lawal, Taiwo Akeem. Department of Surgery, University of Ibadan, and Division of Paediatric Surgery, University College Hospital, Ibadan, Nigeria

Lee, Yoon. Department of Biomedical Engineering, Northwestern University, Evanston, IL, United States of America

Lu, Roy Cheng Chen. Department of Biomedical Engineering, Northwestern University, Evanston, IL, Evanston, IL, United States of America

Makobore, Philippa. Instrumentation Division, Uganda Industrial Research Institute, Kampala, Uganda

Malila, Bessy. Division of Biomedical Engineering, University of Cape Town, South Africa

Michael, Afieharo. Department of Plastic, Reconstructive, and Aesthetic Surgery, University College Hospital, Ibadan, Nigeria

Mulerwa, Martha. Instrumentation Division, Uganda Industrial Research Institute, Kampala, Uganda

Murphy, Robert Leo. Center for Global Health, Northwestern University, Chicago, IL, United States of America

Mutsvangwa, Tinashe E. M. Division of Biomedical Engineering, University of Cape Town, South Africa

Mutswangwa, Christopher. Division of Biomedical Engineering, University of Cape Town, South Africa

Nwaneri, Solomon C. Department of Biomedical Engineering, University of Lagos, Nigeria

Odeniyi, Michael A. Department of Pharmaceutics and Industrial Pharmacy, University of Ibadan, Nigeria

Ojebuyi, Babatunde R. Department of Communication and Language Arts, University of Ibadan, Nigeria

Oladapo, Oyewole Adekunle. Department of Communication and Language Arts, University of Ibadan, Nigeria

Olorunnisola, Abel O. Department of Wood Products Engineering, University of Ibadan, Nigeria

Oloyo, Ahmed. Department of Physiology, University of Lagos, Nigeria

Omobowale, Tayo O. Department of Veterinary Medicine, University of Ibadan, Nigeria

Omotosho, Oladipo O. Department of Veterinary Medicine, University of Ibadan, Nigeria

Osuntoki, Akinniyi A. Department of Biochemistry, University of Lagos, Nigeria

Oyebola, Olusola. Department of Physics, University of Lagos, Nigeria

Oyewola, Olanrewaju. Department of Mechanical Engineering, University of Ibadan, Nigeria

Popoola, Oluwatoyin P. Department of Biomedical Engineering, University of Lagos, Nigeria

Saidi, Trust. Division of Biomedical Engineering, University of Cape Town, South Africa

Shittu, Ayodele Ibrahim. Department of Economics, University of Lagos, Nigeria

Simkowski, Julia. Department of Biomedical Engineering, Northwestern University, United States of America

Sivarasu, Sudesh. Division of Biomedical Engineering, University of Cape Town, South Africa

Soetan, Kehinde Olugboyega. Department of Veterinary Physiology and Biochemistry, University of Ibadan, Nigeria

Sridhar, Mynepalli K. C. Department of Environmental Health Sciences, University of Ibadan, Nigeria

Tade, Oludayo. Department of Sociology, University of Ibadan, Nigeria

Umesi, Donna C. Department of Restorative Dentistry, University of Lagos, Nigeria

Wessels, Edmund. Division of Biomedical Engineering, University of Cape Town, South Africa

Williams, Anika. Department of Biomedical Engineering, Northwestern University, Evanston, IL, United States of America

Zeitz-Chua, Mindy. University of Washington School of Medicine, Seattle, WA, United States of America

Peer Review Statement

The *Biomedical Engineering for Africa* monograph has been through the academic peer review process to conform to the Department of Higher Education and Training requirements.

Each chapter, including the introductory chapter, has been peer-reviewed by senior academics at universities in South Africa, Nigeria and the United States of America. Reviewers are considered subject matter experts.

The review process was as follows:

- *The papers were submitted to reviewers, who provided comments and suggestions.*
- *The Editorial Committee requested authors to correct the manuscripts in accordance with the comments and suggestions of the reviewers.*
- *If the Editorial Committee were satisfied with the revised manuscript, the manuscript was accepted for publication.*

Peer review process confirmed by Dr Reggie Raju (Director: Research and Learning Services, Libraries, University of Cape Town, South Africa).

Foreword

It is with great pleasure that I write the foreword to this much anticipated book on biomedical engineering written by Africans and their collaborators, with an African perspective. High mortality rates, expensive health care systems, and heavy dependence on imported health technology from industrialised countries, motivate the development of technological capacity on the African continent to advance health and healthcare. Biomedical engineering education, research and practice are critical contributors to such capacity.

This book disseminates knowledge in a range of facets of innovation for improved health and healthcare systems. It appropriately emphasises knowledge of context as a critical factor for successful health technology development. Comprehensive coverage of the conception, development and implementation of health-related technologies is accompanied by educational approaches for prospective biomedical engineers and others wishing to contribute health technology innovation. Emphasis has been placed on biomedical engineering best practices for developing countries, especially in Africa, to bring about inclusive developmental outcomes.

Biomedical Engineering for Africa will be a useful guide for aspiring and practicing biomedical engineers, biomedical engineering educators, and other associated professionals. It is heart-warming that biomedical engineering in Africa has come of age. Happy reading!

Professor Folasade T. Ogunsola
Deputy Vice Chancellor, Development Services
University of Lagos, Nigeria
March 2019

Chapter 1

Introduction

T.S. Douglas & R.L. Murphy

Healthcare in low-and middle-income countries (LMICs) lags behind that of the more industrialised and high-income world, primarily because of limited financial and human resources. The disease burden is different, especially for lower-income countries which have high mortality rates from tuberculosis (TB), human immunodeficiency virus/acquired immunodeficiency syndrome (HIV/AIDS), malaria, and other treatable infectious diseases. Infant and maternal mortality related to childbirth also remains unacceptably high. Appropriately designed technologies can be used in the prevention, diagnosis, monitoring and treatment of disease. In the context of LMICs, such innovations can additionally *save many lives*.

Health technology development in LMICs, including countries in Africa, falls far short of meeting the healthcare needs of these settings. The result is a heavy reliance on products and technologies imported from industrialised countries that are often not suited to, or sustainable for, LMICs.

When making decisions to invest in the research and development (R&D) of new products, most device manufacturers that are based in high-income countries often require prerequisite levels of projected annual sales, market growth and rates of return to prioritise project investments. Because of these investment criteria, very few medical devices are designed primarily for LMICs, which are not perceived to provide adequate profit potential. Additionally, because of the way devices and consumables are priced and paid for in developed countries, there is little motivation to develop technologies that are more effective, affordable and accessible, easier to use, and able to deliver superior scalability. Transplanting healthcare systems and technologies from high-income countries to resource-limited settings is slow and expensive, and in many instances, challenging if not impossible. Developing *new* healthcare delivery methods and devices tailored to LMIC environments and conditions is a faster, better and more cost-effective alternative.

Appropriate healthcare products for LMICs are best developed in these countries, where local knowledge and understanding of needs, context and available resources may be incorporated into designs and implementation plans. For local innovation of health technologies to become the norm, capabilities in health technology are required for needs assessment, market analysis, product design, prototyping and testing, manufacturing, distribution and management. In Africa, economic growth, increasing healthcare expenditure, the availability of digital technologies, and young populations provide opportunities for the development of robust health technology innovation systems.

The objectives for enabling health technology development in LMICs include: 1) expanding the base of expertise through research training programmes with a problem-solving focus; 2) stimulating new knowledge, approaches and solutions by enabling innovation; and 3) integrating research communities within and across institutions to build critical mass.

The field of biomedical engineering is central to health technology innovation. Education in biomedical engineering is essential for the development of the skills required to transform healthcare in LMICs through the development and deployment of essential technologies. While biomedical engineering traditionally has operated at the interface of health systems and engineering sciences, it is clear that African approaches need substantial expansion, if they are to address the health technology needs of the continent. For successful implementation of health technology in Africa, biomedical engineers require an in-depth understanding of the social factors that impact on technology adoption, an appreciation of rapidly evolving health systems, as well as an understanding of critical factors such as ethics, regulation, intellectual property management, entrepreneurship and commercialisation.

This book is a response to the need for biomedical engineering capacity in Africa. It is grounded in the African context. It serves as a resource for academics and students in biomedical engineering, for those interested in entering the field in any capacity and for practitioners at every stage of product development. University leaders intent on establishing new biomedical engineering programmes or departments, may draw on the content for guidance on structuring their offerings. The book reaches beyond Africa, as it is relevant to other low-resource settings, and provides insights to guide global health initiatives focused on technology innovation.

Part 1 provides different perspectives on the imperative for biomedical engineering in Africa and describes the development of a set of academic programmes in the field. Part 2 describes a range of considerations and approaches to be applied in converting healthcare needs into products, and includes a methodology for the design of medical devices. Part 3 presents a set of case studies on the design of solutions to address African health-related needs. Part 4 introduces the ethical, legal and regulatory factors that should be considered in the development and implementation of health technologies. Finally, Part 5 places biomedical engineering and its products within the broader health system.

The Editorial Committee wishes to thank the contributing authors for their valuable and constructive input into making this book the first focused on the African biomedical engineering landscape. The contributions of the reviewers are also gratefully acknowledged.

We have an especially strong appreciation for the support provided by the Fogarty International Center of the United States National Institutes for Health (NIH), which funded our project that contributed to the establishment of Departments of Biomedical Engineering at the University of Ibadan and the University of Lagos in Nigeria, through the Framework Programs for Global Health

Innovation (grant # D43 TW009374). The grant solidified the collaboration of academics from these institutions with biomedical engineers at the University of Cape Town and those at Northwestern University in Chicago. In particular, we thank our program officer, Flora Katz, as well as the Director of the Fogarty International Center, Roger Glass, for their encouragement and incredible support.

The Editor received a Visiting Scholar award from the Department of Biomedical Engineering at Northwestern University in 2017. This, combined with support from the NIH-Fogarty grant, enabled preparation for this book.

We have sincere appreciation for the technical and intellectual support of the staff at the University of Cape Town Libraries, who have generously accepted the task of publishing our book as well as our on-line journal, *Global Health Innovation*, under the Open UCT Publications banner.

Part 1

African Perspectives on Biomedical Engineering

Chapter 2

The Case for Biomedical Engineers in African Hospitals: A Clinician's Point of View

D. Atwine

Introduction

This chapter explores the roles that could be played by a biomedical engineer to enhance patient care in the African context through medical device innovation. The need for strengthening cooperation between clinicians and biomedical engineers is emphasised, and some common opportunities that create a platform for building this cooperation are demonstrated. The term “clinician” is used to represent a range of health workers, such as doctors, clinical officers, nurses, and therapists.

Needs and opportunities

The largest needs-based shortages of health workers are in South-East Asia and Africa, with the global shortage projected to be over 14 million health workers in 2030 (WHO, 2016). This human resource constraint within African health systems is further compounded by limited availability of medical equipment. Limited health financing in African countries is the main driver of these constraints, and is a serious obstacle to improving health outcomes on the continent.

In addition, the World Health Organization estimates that more than 50% of medical and related equipment in developing countries are defective (WHO, 2011). This is typically because health facilities are unable to perform adequate maintenance and repairs. The consequences of broken or defective medical equipment include: delays in diagnosis and treatment, over or under-treatment, long-term risks to health, high out of pocket healthcare costs, long hospital stays and, the worst of all, loss of life. The proportion of this unusable equipment is even higher in countries where biomedical engineering has not been fully integrated into the health sector. There is a major problem of inadequate maintenance capability and lack of appropriate human resources to design, develop, and manage medical equipment in less developed countries.

Such a landscape not only creates a challenge in ensuring adequate patient management, but also creates an environment where improvising and innovation becomes part of daily patient care practice. Not only is the training to enable such innovation not included in curricula for healthcare workers, but also the effectiveness of improvised biomedical materials and equipment is rarely evaluated and generally not known. The risks of unevaluated and inappropriate improvisation are high, as they cause harm to patients. Appropriately trained biomedical engineers have the potential

to fill the equipment gaps that exist in African hospitals by transforming the needs of the clinician into practical solutions that meet prevailing standards and requirements.

Potential contributions of biomedical engineers

Could the impoverished health service delivery landscape in Africa offer an opportunity for building a stronger link between clinicians and biomedical engineers for addressing medical equipment needs? Would clinicians embrace this interdependence? The scenarios that follow explore the potential of biomedical engineers to enhance day-to-day patient care in hospitals in Africa. While clinicians are trained in patient care and in using medical equipment, biomedical engineers are trained in maintenance, design and development of such equipment. Biomedical engineers use the principles of both engineering and life sciences in a wide range of applications, for example to design devices and software, to integrate knowledge from many technical sources to develop new procedures, products and methods, or to apply technological research to clinical problems. In the hospital setting, biomedical engineers have a role to play in identifying challenges related to patient care, in innovating and developing customised devices and processes, and evaluating these new devices or processes.

The following are hypothetical situations to illustrate the roles that biomedical engineers may play in enhancing patient care and clinical service in resource limited settings, particularly with a view to addressing the problem of inadequate medical equipment.

Scenario 1: In a certain hospital, the paediatric ward has a neonatal care unit with maximum capacity of 10 beds. This unit only has two oxygen cylinders that can be used on two neonates only at any particular time. On a certain day, four preterm babies with life-threatening conditions requiring pure oxygen are brought to the neonatal unit. Referral is not possible since the next hospital with such facilities is at a distance of 140 km. The clinical records show an increasing rate of neonatal mortality at this unit. An engineering solution that would enable limited available oxygen cylinders to accommodate more infants might be a lifesaving solution.

Scenario 2: An orthopaedic surgeon working in a rural African hospital is frustrated by the poor outcomes of her fracture management procedures. She blames it on the lack of suitable equipment for rehabilitation. Patients are discharged with hardly any equipment to support their early mobility. As a result, bone deformities and contractures are common. Access to a biomedical engineer able to design and build low-cost rehabilitation devices would improve patient outcomes.

Scenario 3: An orthopaedic surgeon at a certain hospital has had much success in managing limb fractures. However, due to the high cost of orthopaedic implants, some of his patients who would otherwise be candidates for implants, are managed using external fixation and require extended limb traction. This results in longer hospital stays due to complications like pressure sores. The design and manufacture of customised mattresses and other devices to reduce the risk of pressure

sores would be of great benefit to patients, would liberate hospital beds by reducing length of hospital stay, and consequently would reduce costs of care.

Scenario 4: The maternity ward of a hospital in a densely populated urban area records about 20–30 deliveries per day, of which 2–5 new-borns are preterm and in need of incubation. The neonatal ward has a premature unit with only one incubator that was donated following a research project conducted in previous years. Neonatal mortality is increasing, with many preterm babies dying of hypothermia due to the shortage of incubators. The purchase of imported incubators has not been prioritised due to the prohibitive cost. Low cost, locally designed and manufactured incubators are likely to reduce neonatal mortality.

The above scenarios demonstrate not only the need for biomedical engineers to address the shortage and high cost of imported medical devices, but also the need for them to work closely with clinicians to assess clinical needs and design context-appropriate devices in response. The scenarios also illustrate the need for scalable devices that can be manufactured in Africa to meet local needs.

Some initial steps to integrate clinical practice with biomedical engineering practice are outlined below.

- Having both groups of personnel agree on the unified goal of establishing good patient outcomes.
- Fostering mutual understanding and respect for the unique roles and skills each group brings in working towards achieving the common goal.
- Ensuring good communication in problem solving activities related to patient care.
- Raising awareness with hospital management and health system administrators of the benefits of clinician–biomedical engineer cooperation in order to garner their support.

Conclusion

If I, as a medical doctor, had been asked six years ago about the role of biomedical engineers in the hospital, my immediate answer would have been: repairing broken beds. This was before I had the opportunity of working with biomedical engineers. Even in the present time, there are many clinicians and policy makers in Africa whose perception of the role of biomedical engineers in hospitals may not be different to mine six years ago. This has hampered the integration of biomedical engineers into the healthcare systems in African countries, causing them to escape into private business, industry and general engineering. It is time for biomedical engineers to be recognized as critical in addressing Africa's healthcare deficits.

References

- WHO. 2011. *Medical device donations: considerations for solicitation and provision*. Geneva: WHO.
- WHO. 2016. *Global strategy on human resources for health: Workforce 2030*. Geneva: WHO. Available: https://www.who.int/hrh/resources/pub_globstrathrh-2030/en/ [2019, May 6]

Chapter 3

Recent Developments in Biomedical Engineering Education in Africa: A Focus on Nigeria and the University of Ibadan

A. Coker, F. Akintayo, C. Achi,
M. Odeniyi, A. Olorunnisola & D. Akano

Introduction

Biomedical engineering (BME) programmes are relatively few in Africa. It was reported in 2008 that only twelve African universities in only six countries offered biomedical engineering compared with 229 universities in North America (Abu-Faraj, 2008). As at 2015, there was less than 0.01 biomedical engineer per 10,000 population in Ghana compared to 0.49 in the United States (Mohedas et al., 2015).

It is evident that developing a critical mass of home-grown BME practitioners – biomedical equipment technicians, clinical engineers and biomedical engineers, all of whom have major roles to play in supporting healthcare delivery – is a prerequisite to improved healthcare delivery in Africa. One of the objectives of a BME programme in Africa should be to contribute to capacity development in this specific sub-sector of Africa's healthcare sector. It is necessary and very desirable to develop a cohort of Africans with the technical expertise to develop and manage processes and products to serve the particular healthcare needs of the continent. Another objective should be the promotion of BME research and innovation. To this end, a special focus must be placed on postgraduate research training.

This chapter provides an overview of initiatives in support of BME education in Africa as well as an overview of BME in Nigeria, with particular reference to the antecedents and features of the recently established BME training programme at the University of Ibadan. This programme was designed to develop a skilled workforce capable of creating new biomedical industries and providing solutions to emerging local and global healthcare challenges.

Initiatives to address the dearth of BME practitioners in Africa

Biomedical and clinical engineers are critical in facilitating the local design, development and production of health technologies in Africa. A number of initiatives have been introduced across Africa to address the dearth of qualified BME practitioners on the continent. These are discussed below.

BME degree programmes

Biomedical engineering degree programmes are growing in Africa. Within the past one and a half decades, a number of new BME degree programmes have been established in many universities in sub-Saharan Africa, including Addis Ababa University, Ethiopia; Kenyatta University and Technical University of Mombasa in Kenya; Makerere University and Mbarara University of Science and Technology in Uganda; Dar-es-Salaam Institute of Technology, Tanzania; the University of Ghana and All Nations University College in Ghana; Universities of Ilorin, Ibadan and Lagos, and Bells University, Ota, all in Nigeria. These programmes, the majority of which are at the undergraduate level, were established largely for the purpose of responding to the needs of the respective countries for technical expertise related to hospital equipment and its management.

African Biomedical Engineering Consortium

A consortium of African universities running, or aspiring to establish, BME degree programmes, founded the African Biomedical Engineering Consortium (ABEC) in August 2012¹. Specifically, the goals of ABEC are to “build the human capital needed to install, maintain and upgrade medical equipment” and to “nurture entrepreneurial and innovative skills to design and develop robust and commercially viable medical devices”. The Universities of Lagos and Ibadan, both located in Nigeria, were accepted as members of ABEC at the annual meeting of the consortium in Addis Ababa in January 2016.

One of the achievements of ABEC is the development of a generic undergraduate BME curriculum which has been adopted, in many cases with some modifications, by some of the participating universities.

Another major achievement of ABEC is the successful organization of five successive annual Biomedical Engineering Innovators’ Summer School (ISS) events with participation of member institutions, and hosted by a different member institution each year². The ISS is an initiative of the United Nations Economic Commission for Africa (UNECA) that is “aimed at fostering the economic development of Africa by stimulating biomedical innovation and improving higher education”. BME students identify a problem that affects health delivery within their country and design a solution to be presented at the ISS after a competitive selection process.

Each ISS is focused on a specific area of need critical for the development of BME skills in Africa. An exploratory ISS was held in 2012; ISS 2013 introduced students to medical device regulation and rapid prototyping; and ISS 2014 had the objective of designing a simple device and exposing students to product development, business planning and marketing (Ahluwalia et al., 2015). The

¹ <http://abec-africa.org/about-us/>

² <http://abec-africa.org/innovators-summer-schools/>

theme of ISS 2015 was the application of mobile telephony in the design of medical devices, while the ISS 2016 had the theme of biomedical and clinical data and informatics.

BME in Nigeria

Nigeria has a well-structured healthcare delivery system comprising primary, secondary and tertiary healthcare institutions. Healthcare provision in the country is a concurrent responsibility of the three tiers of government, i.e., the federal, state and local government. The federal government's role is mostly limited to coordinating the affairs of the university teaching hospitals and federal medical centres (tertiary healthcare), while the state government manages the various general hospitals (secondary healthcare), and the focus of the local government is on dispensaries (primary healthcare), which are regulated by the federal government. Private providers of healthcare also play a visible role in healthcare delivery. However, like with many other countries in Sub-Saharan Africa, Nigeria's healthcare system relies heavily on imported medical devices some of which are not well suited to the tropical environment. It is apposite to note that the major areas of BME practice in Nigeria and many other African countries are in the maintenance, procurement or sale of hospital equipment.

BME practice is not new in the country. Many Nigerians have received training and pursued rewarding careers in diverse areas related to BME for several decades as a result of coordinated efforts between engineers, physicians, pharmacists, physicists and other scientists to fill the gap. Such informal collaboration has been on-going since the 1970s, and attempts to develop training programmes have often failed. The first BME Department in Nigeria was established as a BME Unit in the College of Medicine, University of Lagos, in collaboration with the University of Liverpool in 1974. The Unit was also equipped with facilities for medical diagnosis and research. It was primarily responsible for the repair and maintenance of medical equipment, facilities and installations but was also engaged in training biomedical technologists. The Unit became a full-fledged academic department in 2009, which has introduced postgraduate and undergraduate programmes.

In another positive development, the General Electric (GE) Foundation, in conjunction with the Developing World Healthcare Technology Laboratory at Duke University and Engineering World Health, set up a Biomedical Equipment Technician Training programme at the Federal School of Biomedical Engineering Technology at the Lagos University Teaching Hospital (LUTH), in 2014³. The grant programme expands on the achievements of BMET programmes effectively executed in Rwanda, Ghana, Cambodia and Honduras⁴.

BME in Nigeria has also been strengthened by the activities of a professional organisation. The Nigerian Institute for Biomedical Engineering (NIBE), a non-governmental organisation

³ <http://www.ewh.org/2017-07-12-15-08-39/bmet-training/locations/nigeria>

⁴ <http://www.ewh.org/contact-form/34-programs/bmet/26-bmet-training-program>

representing the biomedical engineering and technology profession and its members in Nigeria and in international organisations, was established in 1999 with the goal of evolving standard and enduring biomedical engineering education, training and practice in Nigeria. It currently has members numbering over 5,000, from the clinical setting, academia, industry, research and training, and the government⁵.

NIBE introduced an annual biomedical engineering conference in 2000. The impact of the conferences on biomedical engineering training in Nigeria was consolidated when NIBE introduced an annual professional development course in 2002 to update members and qualify them as biomedical engineering professionals. The conference and professional development course have been offered every year since inception.

BME education at the University of Ibadan

Established in 1948 as a College of the University of London and transformed into an independent University in 1962, the University of Ibadan (UI) is the oldest university in Nigeria. It is a conventional and comprehensive University noted for excellence in different fields of study including Liberal Arts, Medicine, Basic Sciences, Education, Engineering, Law, Agriculture and Forestry. It is located in south-western Nigeria, 128 km inland northeast of Lagos in Ibadan the third largest metropolitan area in Nigeria, which literally means ‘the town at the junction of the savannah and the forest’.

UI has established itself as a leader in postgraduate education and training in Nigeria and Africa. The University has experience spanning over six decades in administering Master’s degree programmes. A number of academic departments in the University have, over the years, conducted BME-related teaching and research activities in areas such as Radiation and Health Physics, Biomathematics, Computational Biology, Genetics, Cell and Molecular Biology, Data Mining and Machine Learning, Drug formulation and delivery systems, Imaging, Microelectronics, Data Encryption, Pattern and Face Recognition Systems, Modelling of Bio-transportation Processes, Biomechanics, and development of prosthetic devices.

In December 2010, the Vice-Chancellor of UI, Professor I.F. Adewole, now the Minister for Health in Nigeria, expressed a desire for the establishment of a BME programme at UI. Hence, in January 2011 an *ad hoc* committee was set up to prepare the curriculum for a Master’s degree programme in BME. In September 2013, a grant for “Developing Innovative Interdisciplinary Biomedical Engineering Programs in Africa” was awarded by the Fogarty International Center of the National Institutes of Health in the USA to Northwestern University, the University of Lagos, the University of Cape Town, and UI. The activities of this grant gave fresh insights which led to a re-drafting of the curriculum which was approved by relevant organs in UI in the last quarter of 2016.

⁵ <http://www.nigerianbme.org>

The University of Ibadan subsequently commenced a graduate programme in biomedical engineering in 2017. Interdisciplinary capacity development for the programme was facilitated by the NIH-Fogarty grant. The 2-year Master's degree programme was designed to develop a cohort of graduates with the technical expertise to manage and develop processes and products to serve the particular healthcare needs of Nigeria. The objectives of the programme are to:

- offer courses that will lead to the award of a Certificate, a Diploma and a Master's degree;
- provide students with a broad and flexible education in engineering, biological science and medically-related fields; and
- provide training and develop skills in innovation, creativity, adaptability, and critical thinking to solve problems in the biomedical industry.

The programme is currently domiciled in the Department of Mechanical Engineering, Faculty of Technology, until a fully-fledged Biomedical Engineering Department can stand on her feet. The core areas of specialisation, intended to qualify graduates for positions in healthcare facilities, universities, government, or private industry, are biomechanics, clinical engineering and biomedical materials. The programme is intended to attract students from all over Africa, including those who need basic knowledge of BME (an Advanced Certificate obtainable within one semester); those practising BME or who are in related fields and need to enrich their knowledge of BME (an Advanced Diploma obtainable within two semesters); and those that may have obtained tertiary training in related fields and are desirous of furthering their career (a Master's degree obtainable within four semesters). The first cohort of students, whose educational backgrounds were either Mechanical or Electrical & Electronic Engineering, comprised sixteen students. Course delivery is by lectures, tutorials, laboratory/workshop practicals and internships.

The timeline for the development of the BME programme at the University of Ibadan is shown below. In 2018, the foundation was laid for the building that will house the Department of Biomedical Engineering.

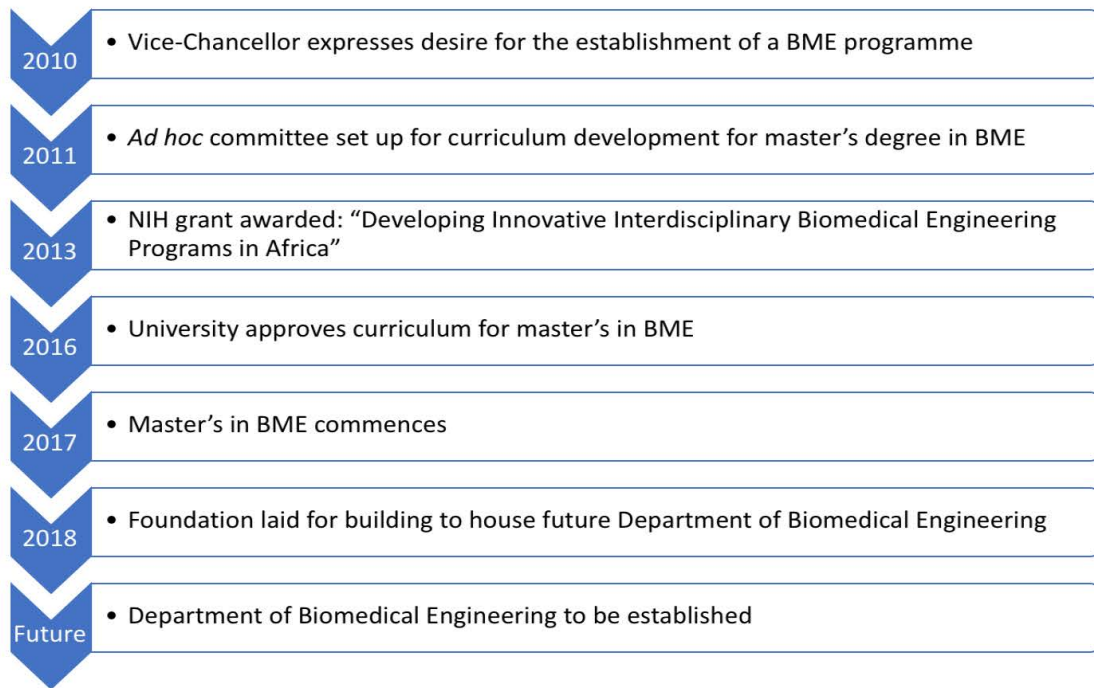

Timeline

for development of BME programme at the University of Ibadan.

Many African universities have concentrated on undergraduate training in BME, providing a potential pool of applicants for the Master's degree programme at UI. A recent survey of the BME graduates in Ghana by Mohedas et al. (2015) showed that the labour market may not be fully ready for the quantum of graduates from the existing undergraduate programmes. An expert group meeting on promoting undergraduate BME innovation for improved healthcare in Ethiopia in January 2016, organised by UNECA in conjunction with ABEC and Addis Ababa University, indicated that the labour market was ill prepared for full engagement of BME graduates. As such, the higher degree programmes at UI provide an opportunity to absorb some of the BME graduates from across the continent and direct their attention and energy to research and development.

Impact of the NIH-Fogarty grant

The NIH-Fogarty grant made it possible for no less than 15 academic staff of UI who teach on the BME programme to visit universities abroad, particularly Northwestern University and the University of Cape Town. The purpose of these visits was to observe teaching and research activities at established BME programmes; to interact with BME faculty and possibly establish mutually beneficial research collaborations; and to audit BME classes, for example in design. These activities served to enhance BME teaching and research activities in the new graduate BME program at UI.

The grant changed the dynamics of interactions between academics in the biomedical and engineering departments at UI. Prior to implementation of the grant, academics in different disciplines were operating largely in silos. However, the opportunity to observe the fruits of collaboration at other institutions with well-established BME programmes, has led to a shift in the mindset of the UI academics who participated in training visits to Northwestern and Cape Town.

In addition to collaborations to teach courses and supervise students' dissertations in the BME Master's degree programme, collaborative research activities have been proposed or are in progress. One of the impacts of the new dynamics is that BME working groups have now been established in UI and a number of research and innovation activities have emanated from these.

Conclusion

Biomedical engineering is still in the developmental stages in Africa in general and in Nigeria in particular. However, the need for the development biomedical engineering education has been identified in order to prepare middle and high-level skills in biomedical engineering and technology. As a result, a number of African and Nigerian universities have created various initiatives aimed at promoting biomedical engineering practice. One of the core initiatives is the establishment of degree programmes, mostly undergraduate, in biomedical engineering. The University of Ibadan started a postgraduate programme in biomedical engineering in 2017. One of the stated goals of the programme is to provide the participants with training and skills leading to innovation, inventiveness, flexibility, and critical thinking with the aim of solving problems in the biomedical industry, medicine, academia, and consulting. The expanding acknowledgment of a felt need to develop health technology locally and the expanding joint effort between African and international institutions bode well for biomedical engineering in Africa.

References

- Abu-Faraj, Z.O. 2008. Project Alexander the Great: a study on the world proliferation of bioengineering/biomedical engineering education. *2008 30th Annual International Conference of the IEEE Engineering in Medicine and Biology Society*. Vancouver, Canada. 2873–2876. DOI: 10.1109/EMBC.2008.4649802.
- Ahluwalia, A., Atwine, D., De Maria, C., Ibingira, C., Kipkorir, E., Kiros, F., Madete, J., Mazzei, D., et al. 2015. Open biomedical engineering education in Africa. *Proceedings of the Annual International Conference of the IEEE Engineering in Medicine and Biology Society*. Milan, Italy. 3687–3690. DOI: 10.1109/EMBC.2015.7319193.
- Mohedas, I., Kaufmann, E.E., Daly, S.R. & H. Sienko. 2015. Ghanaian undergraduate biomedical engineering students' perception of their discipline and career opportunities. *Global Journal of Engineering Education*. 17(1): 34–41. Available: <http://dalyresearch.engin.umich.edu/wp-content/uploads/sites/237/2018/02/Mohedas-Kaufmann-Daly-Sienko-Ghanaian-undergraduate-biomedical-engineering-students-perceptions-of-their-discipline-and-career-opportunities.pdf>. [2019, May 6].

Chapter 4

Creating a Department of Biomedical Engineering and an Undergraduate Programme – The University of Lagos Experience

O.P. Popoola, N.K. Irurhe, O.J. Balogun & A.A. Osuntoki

Background

The University of Lagos (UNILAG) Nigeria was established in 1962. It is located in the southwestern part of Nigeria with a student population of over 40,000 and approximately 3,365 academic, non-academic and technical staff. It has three campuses namely Akoka (main campus), Idi-araba (College of Medicine) and Yaba campuses. There are currently 12 faculties with 9 at the Akoka campus namely: Engineering, Law, Arts, Social Sciences, Education, Environmental Science, Pharmacy, Science, and Management Science, while the College of Medicine at Idi-araba campus houses Basic Medical Sciences, Dental Sciences, Clinical Sciences. All faculties have both undergraduate and postgraduate degree programs. The University also has a Distance Learning Institute.

A Biomedical Engineering Unit was set up at the College of Medicine, University of Lagos in 1974. The purpose of this unit was to maintain laboratory and medical equipment in the College and at Lagos University Teaching Hospital as well as to train biomedical technologists for the nation. The University of Liverpool in the United Kingdom assisted in the creation of the unit, donated equipment, and was involved in the initial training.

The capacity to maintain equipment and ensure functionality is central to the successful provision of healthcare, medical education and biomedical research. The production of this capacity was a key deliverable of the Biomedical Engineering unit, and of its aims was to train technicians to cater for the West African sub-region. Nearly a hundred personnel were trained until government policy on education interrupted the program. During the early period of the unit, it was equipped with state-of-the-art equipment for medical diagnosis and research.

The unit became an academic department under the Faculty of Basic Medical Sciences in the 2009/10 academic session. The department now trains students at undergraduate, postgraduate diploma and master's levels in biomedical engineering (BME). The BME undergraduate programme in the University of Lagos had its first intake of students in the 2017/2018 academic session.

The Department of Biomedical Engineering

Location

The process of starting an undergraduate degree programme in the Department of Biomedical Engineering (which operated only at postgraduate level in the Faculty of Basic Medical Sciences, College of Medicine, until 2017) generated a debate on the domiciliation of the programme and the Department. This is quite understandable. The arguments were along the lines of the definitions implied by “biomedical” or “engineering”, special interests e.g. ownership of programmes, and the nuances of individual preferences. In an attempt to objectively resolve the debate some questions were considered:

- a. What effects will proximity to lecture halls and laboratories have on the students (especially where they have to take courses at locations that require inter-campus commuting)? *The main campus and Idi-araba campus are only about 5.5 km apart however traffic between them can sometimes be chaotic.*
- b. What is the likely effect of the location of the programme on the professional identity of the undergraduate students? *At UNILAG, all engineering programmes were in the Faculty of Engineering.*
- c. Which is/are the appropriate body/bodies responsible for licensing, accrediting and regulating the practice of BME in the country? *Engineering programmes are regulated by COREN in Nigeria.*
- d. Where are the majority of teaching resources for this programme (such as personnel, labs etc.) located?
- e. How best will the domiciliation of the programme enhance the interaction between students, their professional peers, and lecturers from the different faculties and departments in the medical school?
- f. How can administrative bureaucratic bottlenecks be minimised or eliminated in managing multidisciplinary faculty members so as not to be counterproductive?

It was resolved by the university Senate that the undergraduate biomedical engineering programme be domiciled in the Faculty of Engineering but co-located in the College of Medicine for student training.

What should the Department be called?

There is a diversity of nomenclature, focus and scope of BME around the world. In some climes, the ‘bio’ is separated from ‘medical’ to make a distinction between biological engineering and medical engineering. Quite often, the term biomedical engineering was used interchangeably with bioengineering. The usage of these terms often suggested the application of engineering principles to biology, medicine or both. While the former deals with engineering applications in medical sciences and clinical practice, the latter deals with applying biological engineering techniques to understand and control biological organisms. In our own case, there was a debate over the

appropriate name for the programme at the level of seeking of University Senate approval for the undergraduate programme. One school of thought felt it should be “Biomedical Sciences and Engineering” while another felt it should retain the existing “Biomedical Engineering”. The University Senate resolved to retain the existing name.

The undergraduate BME program

Why an undergraduate degree programme in BME?

University of Lagos has offered a post-graduate diploma (PGD) in BME since the 2012/2013 academic session, and a master’s degree (MSc) in BME since 2013/2014. Applicants were admitted from a broad range of disciplines namely sciences, engineering, and medicine. Those with first degree in engineering, mathematics, physics and computer science are admitted directly to the MSc programme while others are required to go through the PGD program.

Our experience is that while those without an engineering background lacked the basic numerical and computational skills required for BME, the engineering students lacked the basic knowledge in biological and medical sciences. Lecturers had to go back to basics (the undergraduate curriculum in the relevant subject areas) in order to make up for the knowledge gap. This made it difficult for most students to attain the desired learning goals within the stipulated time. It also affected the quality of research output. These challenges underscore the critical need to introduce and undergraduate BME program. It is expected that these identifiable difficulties at the postgraduate level will be taken care of at the undergraduate level, so that students entering the master’s programme will be adequately prepared.

Moreover, opportunities abound locally and globally in both the private and the public sectors for biomedical engineers. From medical device manufacturers, hospitals, educational and research institutions, to government and non-government agencies there is an ever-increasing demand to employ engineers who can provide solutions to health challenges. Expensive medical equipment is often either grounded or moribund in many health facilities in Nigeria because they were not originally designed for this climate. Over-dependence on imported medical devices leads to prolonged downtime, loss of revenue and poor patient management in the health sector.

The aim of the programme is to offer comprehensive interdisciplinary training in biomedical sciences and engineering that will position our graduates for innovation in the healthcare industry and research. We endeavour to produce graduates that are resourceful, creative, knowledgeable and able to perform the following functions:

- design and supervise the implementation of biomedical engineering projects;
- design and create products with suitable production techniques for the healthcare industry;
- install, maintain, and optimize the performance of, complex biomedical engineering systems in our environment;
- adapt and adopt foreign technology in solving local biomedical engineering challenges;

- inspire original thought and sound professional judgment in the execution of biomedical engineering tasks;
- manage people of diverse skills and interests, machines, materials and funds;
- boost local problem-solving capability by improving indigenous technology; and
- develop a research culture towards sustainability of healthcare solutions.

Design of the curriculum

In 2011, the University applied to the National Universities Commission (NUC) for approval to commence with an undergraduate degree programme in biomedical engineering. Resource verification was done that year but approval was “put on hold” because there was no existing Benchmark for Minimum Academic Standard (BMAS) for biomedical engineering. This became a challenge which the Department of Biomedical Engineering took up on behalf of the University.

In 2014, UNILAG submitted a draft BMAS to the NUC which was a significant contribution to the development and adoption of a national standard which to be used by NUC for the approval of biomedical engineering programs in Nigeria. Official approval from NUC to commence the programme in UNILAG came in October 2017 and thus the Joint Admission & Matriculations Board (JAMB) gave admission in the 2017/2018 academic session to 27 pioneer students.

The question of what model of curriculum to design was resolved after a global survey of BME curricula, and adaptation of some components of the existing curricula of the University of Liverpool and Northwestern University to suit local needs. Programme contributions and appraisal came from the Council for Regulation of Engineering in Nigeria (COREN) – the professional regulatory body for engineering in Nigeria, and other experts in academia, industry and health at home and abroad.

The curriculum was predominantly developed to meet local needs but applying international best practices. It was tailored to equip our graduates with competence, skill and possibly specialisation in any of the following core areas: biomedical devices, biomechanics and biomaterials (prosthetics design and fabrication), and biomedical modelling. These are in demand both locally and internationally.

Figure 1 shows the distribution of courses in the 5-year programme across basic sciences, engineering, medical sciences, general studies, languages and industrial work experience (the students’ industrial work experience scheme – SIWES).

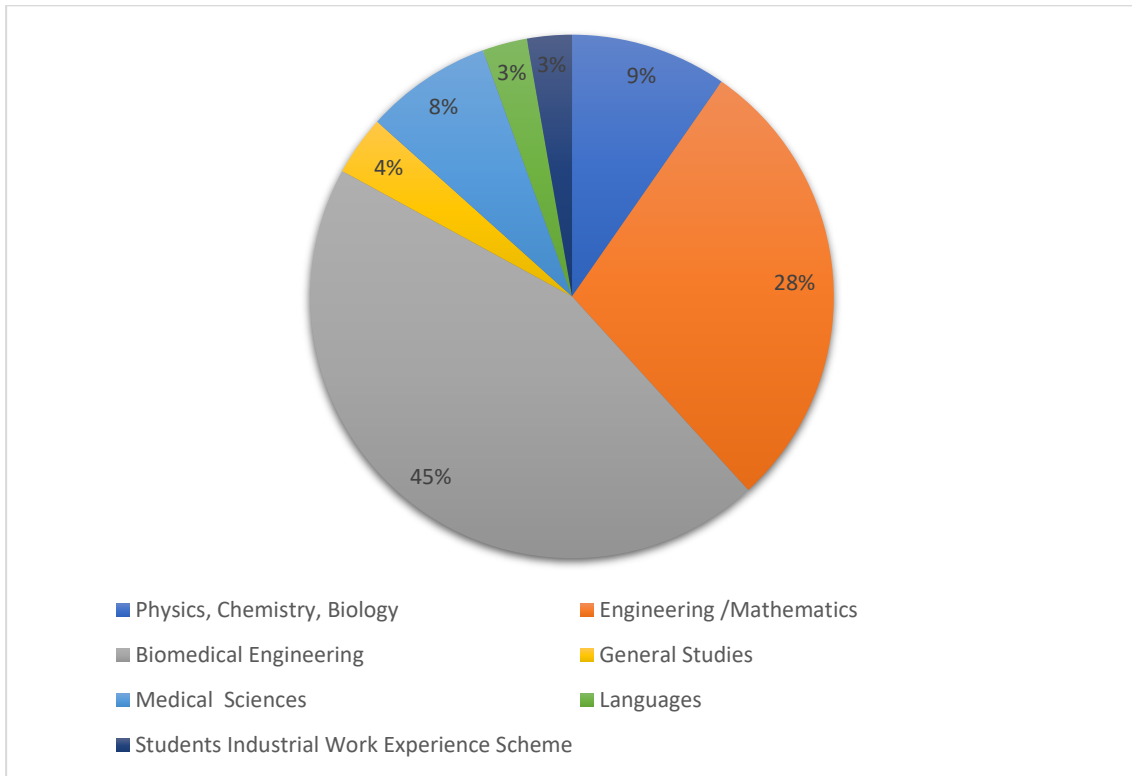

Figure 1: Curriculum distribution for the undergraduate programme

Laboratories

The Department of Biomedical Engineering believes that apart from the shared laboratories with other departments, it should have small units of the following labs:

- *Wet Lab*: where experiments are designed to acquaint students with the methods for acquisition, treatment, and reporting of quantitative information that describes the state of living systems.
- *Design and fabrication labs*: where students have access the tools of a prototyping lab and machine shop. They need to fabricate with various materials ranging from metals to wood, glass and plastic as they design new products and devices. A 3-D rapid prototyping facility is desirable.
- *Computational teaching laboratory*: where students have access to computational workstations installed with design software and integrated videoconferencing capabilities. Modelling and simulation training can be done in this lab.

The Department is hoping to add these facilities to the existing labs in the near future.

Teaching staff

The existing postgraduate programmes have provided the Department with lecturers able to teach the undergraduate courses. However, to reduce the burden on existing lecturers from collaborating

departments (from the Faculties of Engineering and Basic Medical Sciences), more lecturers are being trained and recruited to teach BME undergraduate courses.

Research

There is a paradigm shift in UNILAG from the traditional silos to a more robust interdisciplinary collaborative research culture. BME has been a flagship platform that has popularised collaborative research within the University and also with external partners, especially through the National Institutes of Health (NIH)-funded programme “Developing Innovative Interdisciplinary Biomedical Engineering Programs in Africa”, in collaboration with Northwestern University, the University of Ibadan, and the University of Cape Town. This funding support lasted for 5 years. It afforded the academics involved in the BME programmes and others the opportunity for training visits to the Department of Biomedical Engineering at Northwestern University and other established BME programmes in the United States, as well as for training and project visits to the Division of Biomedical Engineering at the University of Cape Town. It is worthy of mention that the capacity building and training opportunities provided by this project to the benefit of academics from diverse faculties, has largely contributed to motivation for BME and commitment to building the Department of Biomedical Engineering.

The department is also part of the African Biomedical Engineering Consortium¹ and is participating in the African Biomedical Engineering Mobility (ABEM)² project which is funded by the Education, Audiovisual and Culture Executive Agency of the European Commission. ABEM grants scholarships to students to undergo postgraduate programmes and credit-seeking visits to partner institutions. It also facilitates staff exchanges between partner institutions. These will strengthen intra-Africa BME cooperation with the inherent benefits of partnership across institutions.

The BME programme is also being enhanced through NIH support under the Medical Education Partnerships Initiative (MEPI 2) grant, “Building Research and Innovation in Nigeria’s Science” (BRAINS), which supports training and mentored research projects and junior faculty development.

At UNILAG’s Department of Biomedical Engineering, our undergraduate training is aimed at producing engineers who are masters of integration, who know enough about different aspects of medicine and engineering to be able to bring the different knowledge areas and skills together in a practical manner. Although each lecturer has the academic freedom to research in their areas of interest, the following are the core areas in which we are building capacity and developing core competencies at the undergraduate level, with the intention that postgraduate research in these areas will flourish: biomedical devices, biomechanics, biomaterials, and biomedical modelling.

¹ <https://abec-africa.org>

² <https://www.africanbmemobility.org>

Some of the factors that were taken into consideration in arriving at the departmental research focus were: needs that are of significant local and national relevance; the achievable short and long-term goals for biomedical engineering in Africa; global technology trends in biomedical engineering; and resource availability in the immediate or short term.

Our vision

It is the vision of BME at UNILAG to:

- improve and extend the technological capabilities of medical personnel in healthcare delivery;
- operate a department which serves as solution hub for research, medical device manufacturers and clinicians;
- train highly skilled biomedical engineers capable of meeting local needs and global challenges in the biomedical technology space; and
- become the foremost centre of excellence for BME in Africa.

Conclusion

We have discussed our experiences, the motivations and challenges in starting up an undergraduate biomedical engineering programme at UNILAG, and how the challenges have been handled. The experience has helped to form strong interdisciplinary relationships between stakeholders. We believe that the BME programme at UNILAG will be a guiding light in Africa.

Chapter 5

Biomedical Engineering in Ethiopia

A. Hussein & D. Assefa

Introduction

The field of biomedical engineering is fairly new to Ethiopia, where its history is based in meeting the need for maintenance of medical devices. In early 1997, a techno centre was established at one of the largest hospitals in the country, Black Lion Hospital, by a group of technicians and electrical engineers, primarily to address major maintenance problems throughout the country. These professionals were not biomedical engineers but had certifications on medical devices like X-ray scanners, autoclaves, anaesthesia machines and suction machines. At the time, the available health facilities comprised around 96 hospitals, 282 health centres and 802 health posts (El-Saharty et al., 2009). The number of technical professionals was inadequate to service all the health facilities. In addition, spare parts for equipment were not readily available. Most of the devices were imported donations, many of which were not functional. A study published in 2011 revealed that around 39% of the hospital medical equipment in Ethiopia was out of service in 2008, the three main causes being lack of training, lack of health technology management, and lack of infrastructure (Perry & Malkin, 2011).

In the early 2000s, the number of health facilities increased significantly. In 2004–5, there were around 130 hospitals, 600 health centres and 4,210 health posts (El-Saharty et al., 2009). This increase in the number of health facilities increased the interest of donors to provide support in equipping these facilities. Developing the equipment list and specifications was a challenge, as were installation and maintenance. None of the universities at the time had programmes to train the needed technical work force. In 2006 the Ministry of Health entered an agreement with Tegbareid Polytechnic College, Addis Ababa, for the latter to train diploma level biomedical technicians to handle basic installation and maintenance. Training related to biomedical engineering in Ethiopia has mainly focused on equipment maintenance. In 2008 Jimma University launched a biomedical engineering programme at undergraduate level. The Center of Biomedical Engineering at Addis Ababa University was established in 2012 and runs both undergraduate and graduate programmes.

Drivers of biomedical engineering in Ethiopia

The ambitious Growth and Transformation Plan (GTP) of Ethiopia developed in 2010 incorporated a number of strategic directions (MoFED, 2010). One of these is import substitution. It was projected in the GTP that import substitution of pharmaceuticals (a category that includes medical devices in this instance) would reach 50% in 10 years. The plan was to drive manufacturers to establish an industry in Ethiopia for production and assembly of medical devices. Establishing a

medical device industry would need to be supported by biomedical engineers, and is one of the drivers of the expansion of biomedical engineering education in Ethiopia.

Government departments playing a role in the development of biomedical engineering in Ethiopia include the Ministry of Education, the Ministry of Science and Technology and the Ministry of Health. The Ethiopia Society of Biomedical Engineers and Technologists also plays its role, by providing specialised information, mentoring, contributing to curriculum development, and contributing to policy formulation. The society has organised professional meetings and workshops to create awareness of the profession and has worked closely with the government for the development of the field. The society has also been working closely with international partners like the World Health Organisation, the International Federation for Medical and Biological Engineering and UNICEF. Professional peer to peer support has also been implemented in universities and health facilities.

Another factor supporting the production of biomedical engineers is service expansion in the health facilities. Over the past four successive rolling five-year health sector development programmes which started in 1997–8, the number of hospitals in Ethiopia has increased to 146 referral hospitals, more than 3200 health centres and 16,000 health posts (MoH, 2010, 2012). The health sector expansion in infrastructure and service coverage has put a major focus on the need for medical devices and their management at facilities in the three-tier health service delivery system. New and emerging health services like cardiology, oncology and transplantation also drive the introduction of advanced technologies to Ethiopia. Universities and other educational institutions are aligning their fields of study in accordance.

Radiation emitting medical devices, standardisation issues, and calibration and control of medical devices have been substantial concerns associated with the expansion of the health facilities. Services in quality assurance, calibration and standardisation have become driving forces for the development of biomedical engineering education. The government focus on research and innovation has also included the field of biomedical engineering, with four young biomedical engineering innovators being recognised by the Ministry of Science and Technology at the 8th National Science, Technology and Innovation award ceremony held in November 2017.

University programmes

The number of universities running biomedical engineering degree programmes has now reached four. Two of these, Addis Ababa University and Jimma University, have both undergraduate and graduate level programmes while Hawassa University and Gondar University recently launched their BSc level programmes. Addis Ababa University will soon launch a PhD programme in biomedical engineering in partnership with universities in Finland and South Africa. One of the oldest technical and vocational education and training (TVET) colleges in Ethiopia, Tegbare-id

Polytechnic College, runs a biomedical technician programme while other TVET colleges are also following in its footsteps.

The undergraduate programme at AAU is a generic one while the graduate programme is focused on three aspects of biomedical engineering being run under its three research chair groups: biomedical instrumentation & imaging, biomedical rehabilitation, and biomedical computing. The objectives of the graduate programmes include: laying the foundation for an education system that can produce a new generation of biomedical engineers to meet the challenges of the future; improving quality of service in the health sector; producing experts that could run the proposed biomedical manufacturing industries to be erected in the coming years, thereby accelerating national development; providing leadership in creating interdisciplinary academic programmes that are fundamental to addressing the problems facing the country; and providing national and international leadership to the biomedical engineering profession.

With the expansion into bachelor's and master's programmes in biomedical engineering at Ethiopian universities, there is potential to shift the focus from equipment maintenance to innovation, design, research and development.

Challenges for the field of biomedical engineering in Ethiopia

Regulation

Proclamation 661/2009 of the Food, Medicine and Health Care Administration and Control Authority (FMHACA) of Ethiopia, which regulates the safety, quality and efficacy of medicines in this country, has presented a challenge to biomedical engineering. Article 6 of the proclamation categorises medical instruments as a type of medicine and Article 32 defines a “medicinal professional” to be pharmacist, druggist, or pharmacy technician with the appropriate license (FDRE, 1993; FMHACA, 2009). Thus the proclamation has excluded the biomedical engineering role, despite the inclusion of medical instruments, with a negative impact on professional recognition for biomedical engineers. Government policy changes are underway to accommodate biomedical engineering more vigorously.

Awareness about biomedical engineering

Due to the scarcity of biomedical engineers in Ethiopia until recently, the public and in some cases members of the government and health care professionals do not have clear knowledge of what biomedical engineers do. The roles and responsibilities of biomedical engineers and biomedical technicians are sometimes not clearly delineated. The contribution of professional societies and the universities has improved awareness considerably in recent years. In addition, the recent publication by the World Health Organization on the role of biomedical engineers (WHO, 2017) should improve recognition and awareness of biomedical engineering as a profession.

Career path

The lack of knowledge and awareness about biomedical engineering translates into the absence of a clear career path for biomedical engineers. Organisations that might benefit from employing biomedical engineers do not necessarily recruit them. The absence of biomedical engineers from the categorisation of medical professionals by the FMHACA compounds this problem. With changes underway in the FMHACA policies related to biomedical engineering, career paths may become clearer.

Training

Biomedical engineering curricula are varied, with the result that graduates do not leave their undergraduate programmes with a standard set of skills and competencies that is recognised by employers. This has a negative impact on employment of biomedical engineering graduates.

Ethiopian universities have limited availability of teaching laboratories and equipment as well as inadequate research facilities to build sustainable research programmes. The relatively recently established biomedical engineering programmes further strain the universities' ability to provide practical laboratory experience. As a result, universities have shared facilities and have collaborated with better-equipped institutions such as the Tegbare-ed Polytechnic College and the National Metrology Institute, for access to equipment. For practical placements in health facilities, students are sent both to government and to private hospitals, and also to companies operating in the health sector. However, the health facilities lack workshops and equipment for students to gain hands-on experience.

More than 1300 students are currently enrolled for biomedical engineering studies in the four universities running such programmes. Addis Ababa University has 24 teaching staff for more than 600 biomedical engineering students, Jimma University has 30 teaching staff for more than 550 students, Hawassa University has 8 teaching staff for more than 40 students, and Gondar University has 5 teaching staff. These numbers exclude part-time staff on which universities rely given their staff shortages. The universities also have programmes to hire expatriate staff to respond to the chronic shortage in some subject areas.

Academic staff trained to PhD level in biomedical engineering are particularly in short supply, and universities have difficulties in recruiting academics to teach graduate-level courses. Addis Ababa University introduced a master's degree in biomedical engineering in 2012, while Jimma University did so in 2017. Supervision of research projects has been a challenge, which universities have alleviated through the appointment of joint external supervisors and by hiring expatriates. Other than Addis Ababa University, which is to launch a PhD programme shortly, no other PhD programmes in biomedical engineering have been introduced in Ethiopia. Research activity in biomedical engineering at Ethiopian universities is therefore limited, but may be expected to

increase gradually as more PhD graduates are produced and employed by Universities. More research in biomedical engineering is likely to lead to the type of innovation required to establish the medical device industry envisaged by the Growth and Transformation Plan.

Addis Ababa University, Jimma University and Tegbare-ed Polytechnic College are involved in different capacity building projects with local and foreign partners to alleviate the capacity problems described above.

Conclusion

The need and supply of biomedical engineers in Ethiopia is not yet balanced, with need outstripping supply. At the same time, the profession isn't yet well recognised. A number of improvements are underway, with the professional society, universities and government playing a role. Curriculum harmonisation, programme expansion and programme diversification are required. Integration of strategic planning across educational institutions, the industry and health service providers needs careful attention. Universities and technical schools running biomedical programmes should align their strategic capacity development with the long-term health sector development plans of the country. With universities now running undergraduate programmes and expanding into postgraduate programmes, it is expected that the focus of biomedical engineering will shift from equipment maintenance to innovation, design, research and development.

References

- El-Saharty, S., Kebede, S., Olango, P. & Siadat, B. 2009. *Ethiopia – improving health service delivery. Health, nutrition and population (HNP)*. (Discussion paper). Washington, DC: The World Bank.
- FDRE. 1993. *National Drug Policy of the Transitional Government of Ethiopia*. Available: <http://apps.who.int/medicinedocs/documents/s17823en/s17823en.pdf> [2019, May 10].
- FMHACA. 2009. *Food, Medicine and Health Care Administration and Control Proclamation No. 661/2009*. Addis Ababa, Ethiopia: Food, Medicine and Healthcare Administration and Control Authority of Ethiopia.
- MoFED. 2010. *Growth and Transformation Plan (GTP) 2010/11–2014/15*. MoFED, Addis Ababa, Ethiopia. Available: http://www.ethiopians.com/Ethiopia_GTP_2015.pdf [2019, May 10].
- MoH. 2010. *Health Sector Development Programme IV*. Addis Ababa, Ethiopia: Ministry of Health. Available: <https://phe-ethiopia.org/admin/uploads/attachment-721-HSDP%20IV%20Final%20Draft%2011Octoberr%202010.pdf> [2019, May 10].
- MoH. 2012. *Health and Health-related Indicators*. Addis Ababa, Ethiopia: Ministry of Health.
- Perry, L. & Malkin, R. 2011. Effectiveness of medical equipment donations to improve health systems: how much medical equipment is broken in the developing world? *Medical & Biological Engineering & Computing*. 49:719–722.
- WHO. 2017. Human resources for medical devices – the role of biomedical engineers. *World Health Organization Medical Device Technical Series*. Geneva: WHO. Available: https://www.who.int/medical_devices/publications/hr_med_dev_bio-engineers/en/ [2019, May 10].

Part 2

From Needs to Products

Chapter 6

Biomedical Engineering and Entrepreneurship

C.J. Diji, A.I. Shittu, O. Dakare, N. Idusuyi & F. Isaacs

Introduction

Innovation refers to the process of translating an idea into a product, process or service that creates value, or the transformation of an existing product, process or service with the addition of new features. Innovation may be brought about by incremental or radical advances. All innovation begins with creative ideas.

Innovation as it relates to medical devices usually involves the invention of new devices and modification of existing devices. It could also involve appropriation, which means taking an existing device and applying it to a different situation. Biomedical engineering innovation of medical devices may be based on the application of new knowledge from scientific research, or on engineering problem solving; in the latter case, existing knowledge or techniques are applied to newly defined problems.

Innovation requires attention to needs. The well-supported presumption is that when a potential innovator focuses on needs and is attentive to the market of prospective users, he or she can acquire insight into the problems that require solutions and the products that might present suitable solutions.

The identification of a need and the subsequent development of a solution to the need is not the end of the innovation journey. Ensuring that the solution or product reaches the intended beneficiaries and is in fact implemented to address the need, requires a set of activities that may be considered entrepreneurship.

This chapter explores the concept of entrepreneurship, considers the entrepreneurial environment in Africa, and discusses the implications of the latter on the field of biomedical engineering on the continent.

The concept of entrepreneurship

The word entrepreneur is derived from the French verb “entreprendre”, which means to undertake, to attempt, or to try. The term was first introduced by the early 18th century French economist, Richard Cantillon, who defined the entrepreneur as the agent “who buys means of production at certain prices in order to combine them” into a new product and acts as a rational decision maker who assumes risk and manages the firm (Schumpeter, 1951; Kilby, 1971b).

Throughout the history of entrepreneurship, the concept has evolved as scholars from multiple disciplines have grappled with a diverse set of definitions. According to Stokes, Wilson and Mador (2010), the variety of definitions of entrepreneurship could be categorized into three main dimensions of behaviours, processes and outcomes, while others see the concept from the perspective of coordination of productive resources, introduction of innovation and the provision of capital (Hoselitz, 1952). However, the most substantial research into entrepreneurial research was achieved in the 20th century by Joseph Schumpeter who asserted that entrepreneurship and entrepreneurs produce a “creative destruction” which continuously replaces existing components of an economy (Schumpeter, 1934). The definitions range across showing entrepreneurship as a personal characteristic at the micro level of the individual and as an on-going process of transformation at the macro level of the society.

In general, entrepreneurship refers to the ability or the process of creating or adding value by organizing resources to take advantage of an identified opportunity. While it is the individual who takes the necessary steps to become an entrepreneur, a society can transform itself into an enabling environment that encourages entrepreneurship among its members.

Entrepreneurship is today recognized as a socio-economic phenomenon and considered the global panacea to unemployment as well as an essential ingredient for economic development (Bogoro, 2015). There is convincing evidence of a link between entrepreneurship and national development, especially in developed countries in America, Europe and Asia (Kilby, 1971a). For this reason, developing countries are vigorously embracing entrepreneurship, because beyond the realms of business and economy, the concept has become a positive way of life: a way of thinking, reasoning, behaving and acting (Timmons & Spinelli, 2004).

The entrepreneurial environment in Africa

Africa has received global attention in the 21st century as the continent for new growth and opportunities. There has been considerable debate on how African governments can create significant numbers of jobs and develop home-grown business leaders able to access global markets and propel growth in a sustainable and inclusive manner. Sustained growth and development depend crucially on, among other things, the capacity and willingness of African countries to create on a sustained basis an enabling environment conducive to the emergence of entrepreneurship in the public and private sectors.

One set of factors determining the entrepreneurial environment includes the overall economic, socio-cultural and political situation that influences people’s willingness and ability towards entrepreneurship, while another addresses the availability of support services that promote the creation of new enterprises.

Entrepreneurship and local private enterprises are critical components of African economic development (McDade, 2002) and are central to Africa's future prosperity. Fostering entrepreneurship is, therefore, vital for African countries if they are to develop and transform their economies. The biggest business opportunities in the coming decade will require Africans who are able to start businesses, create jobs and generate wealth, and recognise and take advantage of growth opportunities. However, African entrepreneurship can only thrive under a favourable entrepreneurship environment.

The 2017 *African Economic Outlook* report (AFDB, OECD & UNDP, 2017) reveals some interesting statistics about entrepreneurship on the continent. Africa is the region with the highest proportion (22%) of adults starting or running new businesses in the world, although there is considerable variation across African countries. Thirty-eight percent of African entrepreneurs are in the 25–34 age group, reflecting the continent's demographics and its young population. Firms that are younger than five years old and have fewer than twenty employees provide most of the new jobs in Africa's formal sector, with most African entrepreneurs (55%) focusing on lower skill sectors such as retail trade, hotels and restaurants; manufacturing accounts for only 8%. Africa also has a high rate of female entrepreneurs, with African women being twice as likely to start a business than women elsewhere.

However, despite the positive developments and encouraging trends shown on the continent in recent years, the troubling reality is that African entrepreneurship has been driven largely by necessity rather than by opportunity seeking. Necessity entrepreneurs start a firm because of a lack of employment opportunities. They generally use existing technologies and processes, and lack high growth prospects, while opportunity entrepreneurs pursue independence and profit; they have strong motivations towards innovation and growth, and look beyond local markets and existing products and services (Austin, Stevenson & Wei-Skillern, 2006). African entrepreneurs tend to enter sectors that require lower skill levels, have fewer barriers to entry, have quick turnover, and do not require long-term investment (AFDB, OECD & UNDP, 2017). This contrasts with the situation in high-income countries, where technology and service industries are where nearly half of entrepreneurs start new businesses (Herrington & Kew, 2017).

Implications for biomedical engineering in Africa

Biomedical engineering practice in Africa offers tremendous opportunities for designing and providing appropriate medical devices for hospitals and other medical facilities through entrepreneurship development and practice. Below are some examples of biomedical engineering-related entrepreneurship in Africa.

The Cardio-Pad¹ was developed by Cameroonian Arthur Zang. It is used to detect cardiovascular disease in patients who live in remote areas and are unable to access health services offered in the

¹ <https://himore-medical.com/products/hardwares/cardiopad>

city. The device is used to determine whether the heart is functioning normally by collecting data from four electrodes attached to the chest of the patient; the data are transmitted wirelessly to a cardiologist who is then able to provide a diagnosis. The device has been sold in India, Nepal, Gabon and Cameroon.

Deaftronics², a company in Botswana, built a prototype solar charger for solar power hearing aid batteries that would last for three years and could be used with many hearing aids available on the market. It was developed for the hearing impaired in developing countries who are unable to access electricity to charge their hearing aids. The batteries are recharged via sunlight, household lights or even cellphone chargers. The company brought the device to market and receives revenue through the sales and manufacturing of hearing aids, solar chargers and batteries.

In South Africa, Power Free Education Technology (PET)³, a Non-Profit Organisation, developed a wind-up Doppler ultrasound fetal heart rate monitor to detect fetal distress. It is used in the rural areas of developing countries to monitor fetal heart rate while the mother is in labour. The organisation entered into a partnership with the Phillips Africa Innovation Hub to develop, test and commercialise the device.

These are only a few examples of medical device innovation and entrepreneurship on the African continent. Many innovators from Africa apply for venture capital or make use of funding mechanisms like that provided by the Lemelson Foundation⁴ which provides funds and support to entrepreneurs. Saving Lives at Birth⁵ has also funded a number of biomedical engineering entrepreneurs from Africa. The Grand Challenges Explorations programme⁶, which supports innovation in global health, is another relevant funding mechanism.

Challenges for African biomedical engineering entrepreneurship

The challenge in developing an African entrepreneurial biomedical engineering environment is not only the lack of infrastructure but also the lack of innovative capacity and ecosystems that support innovation, as well as a fragile healthcare system on the continent.

As evident from the examples above, local production of medical devices on the continent could offer a cost-effective route to improving access to appropriate healthcare; however, the absence of an innovation-supportive setting for the production of economically viable medical devices, may serve to hinder local innovation and development and in turn limit the ability to meet local health care needs. Thus, improved access to medical devices in Africa will require a competent, innovative and well trained cadre of biomedical engineers operating in a supportive business environment to

² <https://scalingpathways.globalinnovationexchange.org/organizations/deaftronics-pty-ltd>

³ <https://pet.org.za>

⁴ <https://www.lemelson.org/our-programs/developing-country-programs/incubation>

⁵ <https://savinglivesatbirth.net>

⁶ <https://gcgh.grandchallenges.org>

produce needs-appropriate and economically viable devices, with appropriate financing mechanisms to connect producers, payers and consumers; and regulations and policies to support equitable access to and quality of devices.

The innovative capacity of the African biomedical engineer to meet the current health care needs of the continent will, in part, depend on the robustness of the higher education system in general and the training and development of biomedical engineers in particular in various universities and colleges of engineering across the continent. It will also depend on the sharing of limited academic resources. There is therefore an urgent need to create a robust and integrated biomedical engineering training system on the continent; this will contribute to the creation of a culture of cross-country sharing of ideas and an ecosystem of collaboration for biomedical engineering innovation to support entrepreneurship.

References

- AFDB, OECD & UNDP. 2017. *African economic outlook 2017: entrepreneurship and industrialisation*. Paris: OECD Publications. DOI: <http://dx.doi.org/10.1787/aeo-2017-en>.
- Austin, J., Stevenson, H. & Wei-Skillern, J. 2006. Social and commercial entrepreneurship: same, different or both? *Entrepreneurship Theory and Practice*. 30(1): 1–22.
- Bogoro, S.E. 2015. Entrepreneurship for development. *Convocation lecture delivered at 2nd Convocation Ceremony of the Kaduna State University*, Kaduna, December 11th. Kaduna State University, Kaduna: Nigeria.
- Herrington, M. & Kew, P. 2017. *Global entrepreneurship monitor: global report 2016/17*. Global Entrepreneurship Research Association (GERA). Available: <https://www.gera-ngo.org> [2019, May 27].
- Hoselitz, B.F. 1952. Entrepreneurship and economic growth. *American Journal of Economic Sociology*. 12(1): 97–110.
- Kilby, P. 1971a. *Entrepreneurship and economic development*. New York: Free Press.
- Kilby, P. 1971b. Hunting the Heffalump. In *Entrepreneurship and economic development*. P. Kilby New York: Free Press. 1–25.
- McDade, B.E. 2002. Industry, business enterprises, and entrepreneurship in the development process. In *Geography of sub-Saharan Africa*. S. Aryeetey-Attoh & B.E. McDade, Eds. Upper Saddle River, NJ: Prentice Hill. 406–424.
- Schumpeter, J.A. 1934. The creative response in economic history. In *Essays on entrepreneurs: innovations, business cycles, and the evolution of capitalism*. J.A. Schumpeter, Ed. New Brunswick: Transaction Publishers. 221–231.
- Schumpeter, J. A. 1951. *Essays of J. A. Schumpeter*. Cambridge, MA: Addison-Wesley Press.
- Stokes, D., Wilson, N. & Mador, M. 2010. *Entrepreneurship*. Hampshire, UK: South-Western/Cengage Learning EMEA.
- Timmons, J.A. & Spinelli, S. 2004. *New venture creation entrepreneurship for the 21st century*. 6th ed. Boston: MacGraw-Hill.

Chapter 7

Problem Identification and Needs Assessment for Healthcare Technologies

T. Saidi, O.O.E. Ajibola, A. Desmennu, B.R. Ojebuyi, O.A. Oladapo,
O. Tade, C.G. Achi, O.J. Balogun, S.C. Nwaneri, A.I. Aiyegbusi,
D.C. Umesi, A.B. James, A.O. Coker & C.J. Achenbach

Introduction

Appropriate healthcare technologies are important tools to improve health and are broadly defined as “methods, procedures, techniques and equipment that are scientifically valid, adapted to local needs and acceptable to those who use them and to those for whom they are used” (WHO, 2004). Several characteristics are vital to the success of healthcare technologies, particularly in resource-limited settings. They must be accurate, effective, safe and affordable (Ren et al., 2015). Studies on health technology in low resource settings have emphasised the challenges impeding access including capacity constraints resulting from lack of physical, financial and human resources (Chandrasekhar & Ghosh, 2001; Malkin, 2007; Clifford et al., 2008). Understanding previous internal and external barriers to development and implementation of health technologies is extremely important for resource-limited settings as we advance scientific progress in this area.

A key skill that requires training and practice is the ability to identify a biomedical problem and perform a diligent and multi-disciplinary local needs assessment for that problem (Sinha & Barry 2011). Understanding user needs is critical, as complex health technologies are often impractical and unusable in resource-limited countries. Thus, there is a mismatch between problems and identified and procured technologies. Proper identification of the problem and needs assessment can also be helpful to minimize wasteful and inappropriate use of precious local resources (WHO, 2001).

There is consensus on the importance of problem identification and needs assessment for healthcare technologies, but what is less clear, is the process. There is no ‘one size fits all’ approach for health technology needs assessment; as argued by the World Health Organisation (WHO, 2011), needs must be assessed according to different scenarios and under varying circumstances for specific communities. The World Health Organisation has proposed initiatives towards a scheme for needs assessment to increase access to appropriate and well-developed healthcare technologies.

Problem identification

The first step in developing healthcare technology is to identify a clear biomedical problem with a potential engineering solution and creating a clear statement of the problem that the intended

technology will address. This problem statement must be accessible and easy for even a novice to understand and must clarify the objective of the engineering design task.

A first step in identifying a biomedical problem is what is referred to in a biomedical engineering design course at the University of Lagos as “disease hunting.” This entails identifying a medical condition requiring diagnosis, therapeutic management or disease monitoring, as well as its presentation or symptoms. Problem identification often requires consultation with physicians or public health officials aiming to improve individual or population health. Multidisciplinary brainstorming meetings between healthcare providers, clinical laboratory leaders, and engineers can be helpful to identify biomedical problems with potential local technology solutions. Often, ideas are generated based on personal experience or interest. A review of the literature can aid in refining the problem to be addressed.

An example from the biomedical engineering programme at the University of Lagos, was an engineering graduate student who had experienced football injuries. Cryotherapy emerged from the student’s literature review as a treatment for pain (MacAuley, 2001; Hubbard & Denegar, 2004; Mars et al., 2006), and timing of application of this therapy was key to success. After identification of this general problem, the student consulted with local family medicine and orthopaedic doctors who recognised a lack of immediate (on-field) treatment options for football soft tissue injuries. Having established cryotherapy as a possible solution, other considerations suggested by medical experts were device wearability and portability, maintenance of a pre-set steady temperature, and capacity to be monitored remotely by a third-party device in real time. Finally, the student determined a specific problem to be solved: immediate cryotherapy for treatment of soft tissue injuries on the field. The student aimed to answer the following engineering question – can we locally design a novel technology that immediately utilizes cryotherapy to treat soft tissue injury in an athlete? In response to the requirements identified, a simple low-cost device, namely an electronic ice cuff, was developed (Ajibola & Folorunso, 2017).

The biomedical problem is relative to the local environment and must be conceptualised in conformity with local resources, biomedical ethics, socio-cultural factors, and ergonomic and other situational parameters. Ultimately, a well-considered, well-researched and challenging biomedical problem will have compelling engineering design questions that will demand to be answered.

Approaches to needs assessment

Once the biomedical problem has been identified, a proper needs assessment should be performed. A well-executed needs assessment for a healthcare technology involves the identification and definition of prioritised requirements as well as considerations of potential impacts on users, with the aim of improving health or health service delivery (Wright, Williams, & Wilkinson, 1998; WHO, 2011). In the context of health technology design, an excellent needs assessment enhances biomedical problem identification and guides design choices to solve the problem and answer engineering design questions.

In general, when conducting a needs assessment, it is imperative to consider unique diagnostic, treatment, and preventative approaches in the context of the problem and its solutions (Söderback, 2015; Saidi & Douglas, 2018). Health technology must fit local circumstances and conditions in the light of available national resources, infrastructure, knowledge and skills. Thus, a location-specific needs assessment is vital to ensure that appropriate technologies are effective, appropriate, cost-effective and do not consume resources from other critical healthcare areas (Sinha & Barry, 2011; van Niekerk et al., 2017).

An understanding of technology and its implementation as being socially shaped and influenced by values, beliefs and culture, demands that the gap between science and society be bridged to enable technology to be configured for different contexts (Saidi & Douglas, 2018). The extent to which a health technology can successfully be deployed in society, depends on the extent to which it is integrated into the healthcare community, in a manner that informs its design (Webster, 2002) and draws on the different knowledge systems of health technology stakeholders (Sorensen & Iedema, 2008). The relevance of health technology can be improved by extending the boundaries of the knowledge systems that feed into their development beyond clinicians and managers. The nature of healthcare technology requires a network consisting of a wide variety of stakeholders in society, such as regulatory agencies, patient advocacy groups, bioethics committees and physicians. These groups can, if given the opportunity, scrutinise healthcare technology from varying perspectives before it is deployed for use, and ideally during the design phase. Early engagement of these groups is crucial as technological development in healthcare is rapidly evolving as a collective, multi-professional and multi-disciplinary process which challenges the entrenched traditional, individualist, 'taken-as-given' culture (Sorensen & Iedema, 2008). Patients, caregivers and others with relevant lived experiences can offer valuable insights that help characterize the challenges and assess the healthcare needs these technologies should address. Figure 1 suggests an iterative approach to problem refinement and needs assessment, as these steps are not clearly separable in practice.

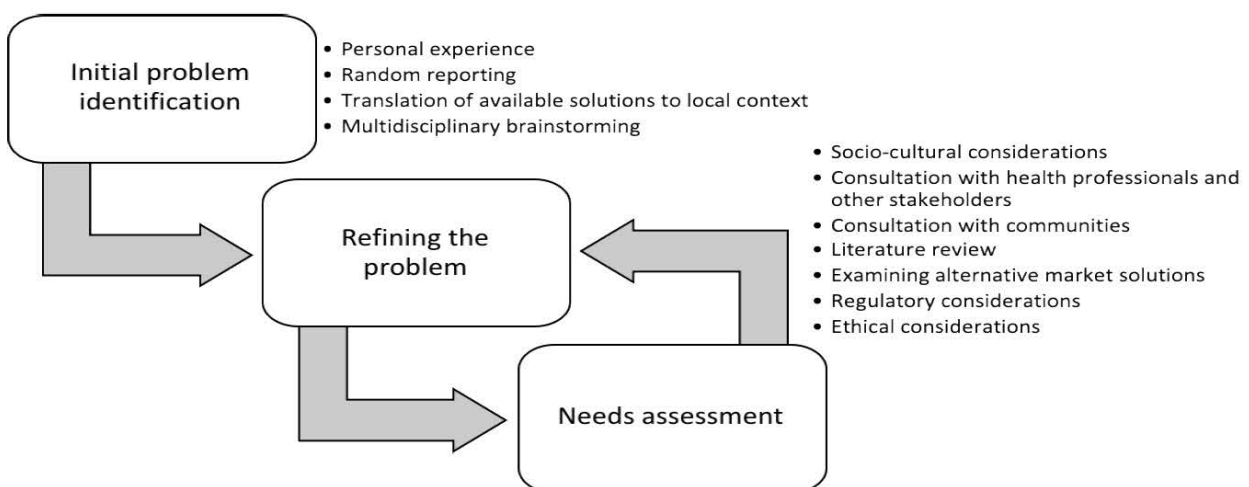

Figure 1: Problem identification and needs assessment

Implications for biomedical engineers

Efforts must be made to ensure that biomedical engineering research, design and practice does not neglect the needs of vulnerable groups. Examples include children, pregnant women and the elderly who have particular medical requirements. Consideration should also be given to persons with disabilities. For example, for individuals with visual and hearing impairments, conventional means of communication may be a critical barrier when stakeholder views are solicited to inform design decisions. In addition, the healthcare needs of those who have poor access to health facilities due to geographical location, limited financial resources and other forms of marginalisation are pertinent in the African context. Therefore, biomedical engineers should communicate and engage with society and health-related stakeholders to determine engineering design problems, questions and needs. In practice, a biomedical engineer should understand the actual need for the product and the potential implications of the new product as well as its suitability for the user with regard to their level of education, gender, cultural preferences, religious sentiments, ethnic peculiarities, and interests.

Conclusion

Problem identification and needs assessment are important for ensuring that users are able to access healthcare technologies that meet the realities of their local circumstances. These considerations are aimed at closing the design-implementation gap that emerges when healthcare technologies are designed and built to satisfy assumed demands or needs that may not exist. Engineers can accomplish these goals through public engagement, incorporation of different knowledge systems, situating technology in their social context, and customisation. Problem identification and needs assessment are pro-active steps in the development of technology that is inherently responsive to the specific needs of local users and stakeholders.

References

- Ajibola, O.O.E. & Folorunso, P.O. 2017. Analysis, design and construction of electronic ice cuff for athletes. *International Journal of Medical Engineering and Informatics*. 9(3): 220–236. DOI: <https://doi.org/10.1504/IJMEI.2017.085048>.
- Chandrasekhar, C. & Ghosh, J. 2001. Information and communication technologies and health in low income countries: the potential and the constraints. *Bulletin of the World Health Organization*. 79(9): 850–855. Available: <https://www.scielosp.org/pdf/bwho/2001.v79n9/850-855/en> [2019, May 20].
- Clifford, G.D., Blaya, J.A., Hall-Clifford, R. & Fraser, H.S. 2008. Medical information systems: a foundation for healthcare technologies in developing countries. *BioMedical Engineering OnLine*. 7: 18. DOI: <https://doi.org/10.1186/1475-925X-7-18>.
- Hubbard, T.J. & Denegar, C.R. 2004. Does cryotherapy improve outcomes with soft tissue injury? *Journal of Athletic Training*. 39(3): 278–279. https://www.ncbi.nlm.nih.gov/pmc/articles/PMC522152/pdf/attr_39_03_0278.pdf

- MacAuley, D. 2001. Ice therapy: how good is the evidence? *International Journal of Sports Medicine*. 22(5): 379–384.
- Malkin, R.A. 2007. Barriers for medical devices for the developing world. *Expert Review of Medical Devices*. 4(6): 759–763. DOI: <https://doi.org/10.1586/17434440.4.6.759>.
- Mars, M., Hadebe, B. & Tufts, M. 2006. The effect of icepack cooling on skin and muscle temperature at rest and after exercise. *South African Journal of Sports Medicine*. 18(3): 60–66. Available: <https://journals.assaf.org.za/index.php/sajsm/article/view/237> [2019, May 20].
- Ren, J., Liu, C., Gao, Q.-S., Yang, L., Huang, X., & Guo, Q. 2015. Use of appropriate healthcare technologies: a cross-sectional study in rural Zhejiang of China. *BMC Health Services Research*. 15(1): 295. DOI: <https://doi.org/10.1186/s12913-015-0947-4>.
- Saidi, T. & Douglas, T.S. 2018. Towards the socialization of science, technology and innovation for African development. *African Journal of Science, Technology, Innovation and Development*. 10(1): 110–113. DOI: 10.1080/20421338.2017.1399534.
- Sinha, S.R. & Barry, M. 2011. Health technologies and innovation in the global health arena. *New England Journal of Medicine*. 365(9): 779–782. DOI: 10.1056/NEJMp1108040.
- Söderback, I. 2015. The genesis of international handbook of occupational therapy interventions. In *International handbook of occupational therapy interventions*. L. Söderback, Ed. Switzerland: Springer. 19–25.
- Sorensen, R. & Iedema, R. 2008. Redefining accountability in health care: managing the plurality of medical interests. *Health*. 12(1): 87–106. DOI: <https://doi.org/10.1177/1363459307083699>.
- van Niekerk, L., Chater, R., Naydenova, E., Lim, J., Chamas, L., Manderson, L., Gilson L., Peeling R., et al. 2017. *Social innovation in health: case studies and lessons learned from low-and middle-income countries*. Geneva: World Health Organization. Available: <https://apps.who.int/iris/bitstream/handle/10665/259187/9789241513098-eng.pdf> [2019, May 20].
- Webster, A. 2002. Innovative health technologies and the social: redefining health, medicine and the body. *Current Sociology*. 50(3): 443–457. DOI: <https://doi.org/10.1177/0011392102050003009>.
- WHO. 2001. *Health care technology management: country situation analysis*. Geneva: World Health Organization. Available: <http://www.who.int/iris/handle/10665/119645> [2019, May 27].
- WHO. 2004. *A glossary of terms for community health care and services for older persons*. Geneva: World Health Organization.
- WHO. 2011. *Needs assessment for medical devices*. (WHO: Medical Device Technical Series). Geneva: World Health Organization. Available: <http://www.who.int/iris/handle/10665/44562> [2019, May 27].
- Wright, J., Williams, R. & Wilkinson, J.R. 1998. Development and importance of health needs assessment. *British Medical Journal*. 316: 1310. DOI: <https://doi.org/10.1136/bmj.316.7140.1310>.

Chapter 8

Frugal Biodesign: An approach for Developing Appropriate Medical Devices in Low-resource Settings

S. Sivarasu

Introduction

Medical devices are indispensable in the prevention, diagnosis and treatment of illness and disease, as well as in rehabilitation. The World Health Organization has emphasised that the achievement of health-related development goals is dependent to a large extent on the accessibility of appropriate, good quality, safe and affordable medical devices that are compatible with the settings in which they are used (WHO, 2017). In order to ensure access to appropriate medical devices, it is important to understand the specific needs of the country, region, community, or facility. An understanding of the context is important to avoid unnecessary wastage of resources, particularly from inappropriate investments in medical devices that fail to meet high-priority needs, do not suit existing infrastructures, and do not function effectively and efficiently (WHO, 2010a).

This chapter describes a course on medical device design, which is aimed at improving access to suitable medical devices in South Africa, a country with multiple health changes that require innovative approaches. It starts by giving an overview of medical device challenges in developing countries and of the medical device sector in South Africa, and proceeds to explain the structure of the medical device design course offered to postgraduate students in Biomedical Engineering at the University of Cape Town.

Medical device challenges faced by developing countries

In low- and middle-income countries, medical devices are often a low priority or even absent from the agenda; developing countries lack policies, budgets, infrastructure (basic services, human resources, logistics), as well as rules and regulations pertaining to medical devices (WHO, 2010a). These constraints result in many developing countries relying on medical device donations. In some countries, nearly 80% of health-care equipment is donated or funded by international donors or foreign governments (WHO, 2000; Finch et al., 2014; Borrás, 2017). Although donations of medical devices can be of great value to health facilities with limited resources and are generally made with good intentions, the outcomes are not always positive (Sodhi et al., 2014). For example, donations can be problematic when they are provided without taking into consideration the particular needs of the end-users. There is a risk that poor communication between donors and recipients of medical devices may result in the former not being aware of the local realities of the latter (WHO, 2011). This may result in the donation of inappropriate medical devices which are technically unsuitable, or incompatible with existing equipment. The WHO (2010b) points out that

a large number of medical devices that are acquired by developing countries from developed countries remain idle, or are sub-optimally or inappropriately used. Jones (2013) cites an example of incubators for premature babies which were donated in a developing country, but did not function because they required a higher electrical voltage than is standard. However, health facilities with limited resources are reluctant to decline or complain about donations as they feel obliged to accept them (Kaur, Hall & Attawell, 2001).

Many developing countries have renowned and productive scientists who are capable of contributing to the medical device industry. However, due to lack of funding, such scientists may end up working on research projects whose objectives are determined by funders in developed economies (Lorentzen & Mohamed, 2010). This poses the danger of developing inappropriate technologies that have very little utility for developing countries, resulting in low take-up by industry. The developing countries become a source of 'brains-for-hire' as scientists go into consultancies where they sell their skills to the highest foreign bidder rather than joining university departments (Lorentzen & Mohamed, 2010). Although globalisation opens opportunities for developed and developing countries to interact, it also poses threats in that global knowledge networks rarely accommodate small players who are left with the option of either being absorbed or left out (Krishna, Waast & Gaillard, 1998).

The conventional approaches to innovation in medical devices are difficult to implement in low-resource settings. Hobday (2005) argues that the various generations of firm-level innovation models used in developed countries such as the United States of America and Japan do not appropriately cater for latecomers from developing countries. The models tend to concentrate on large firms that pursue highly structured research and development, which is geared towards market products at the expense of smaller firms that more informally pursue innovation. The major shortfall of these models is that they prescribe practices which are considered appropriate for other countries (Tödting & Trippel, 2005). This is subject to debate as Hobday (2005) argues that one of the essential features of innovation is rule-breaking rather than identifying and pursuing rules or patterns. Langergaard and Hansen (2013) point out that the appropriateness of a model for innovation depends, to a large extent, on the context. Considering the differences in resource endowment between countries in the developed and developing world, it is not possible to approach the development of medical devices with a 'one size fits all' model. Instead, it is important to understand the particular circumstances of each country and respond with customised approaches.

The medical device industry in South Africa

The South African medical device industry is growing and holds huge potential for contributing towards health care. According to SAMED (2014), the industry was estimated at USD1.2 bn in 2013 and ranked among the top 30 largest in the world; it was expected to grow by a compound annual growth rate of 7.7% between 2013 and 2018. Despite the positive outlook on the growth of the

medical device industry in South Africa, the dominance of imports, which cater for about 90–95% of the market by value, is conspicuous (Abbott, Correa & Drahos, 2013). As a result, the market is inundated with imported medical devices which may not be appropriate and affordable. The imports undermine the development of medical devices by local manufacturers, most of whom cannot compete with multinational companies. The medical device market in South Africa targets clients mainly from the private sector, which constitutes 70% of the market and where most of the revenue is consequently derived (KPMG, 2014). This reflects a dichotomous health system which is characterised by a well-developed private sector and an overburdened public sector, leaving room for the development of medical devices that are appropriate for public sector needs.

Frugal Biodesign in a medical device course

Frugal Biodesign is a unique approach to medical device design that is suited specifically to developing countries. It is aimed at stimulating postgraduate students studying Biomedical Engineering to devise inexpensive and, more importantly, innovative solutions to medical problems. It takes cognisance of the limitations that South Africa and other developing countries experience in terms of human, financial and physical resources.

The medical devices that the students work on during this course are informed by clinicians. The course adopts a cyclical and dynamic approach that involves the constant exchange of information between multiple stakeholders in the medical device sector as shown in Figure 1. The stages are discussed below.

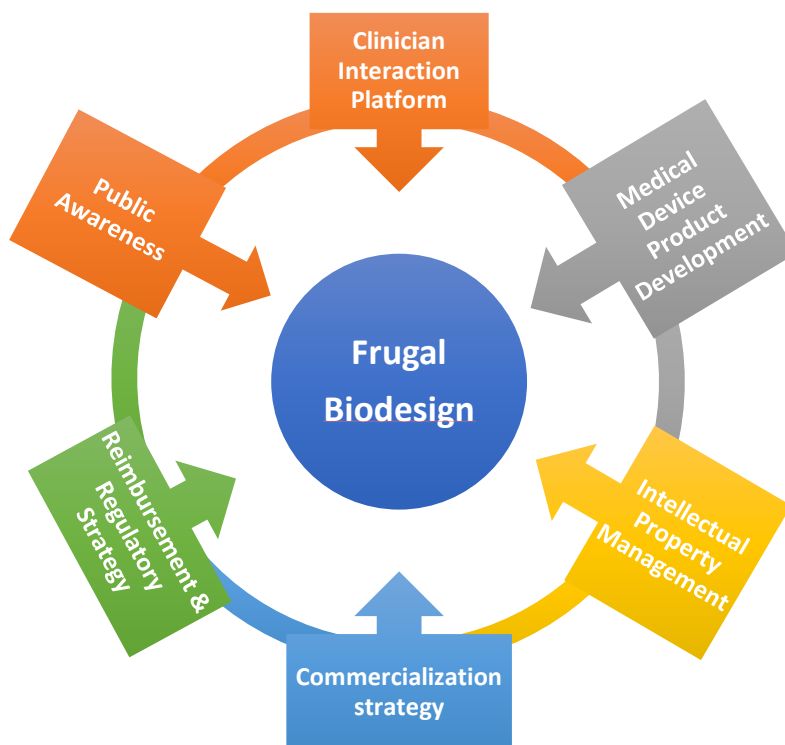

Figure 1: The stages of the Frugal Biodesign approach

Course structure

The two-semester, 10-month course on medical device design applies the principles of Frugal Biodesign and engineering design methodologies to fast-track the process of ideation. Ideation starts with identifying a need and continues until proof of concept is achieved.

In the first semester, the students are expected to work on 3 major themes, namely, 1. Needs identification and screening; 2. Concept generation and screening; and 3. Strategy development. These themes involve screening for an unmet clinical need, and identifying appropriate solutions. Various concepts are generated to solve the unmet clinical need and these design concepts are screened on the basis of manufacturability, patentability and clinical usability. For the clinical need and the concept design, a thorough intellectual property search is performed. The deliverables for the first semester of the course include: 1. A detailed needs analysis report; 2. A design report on concept generation and screening; 3. A design report on strategy for conceptual design realization; and 4. A completed University of Cape Town invention disclosure form for intellectual property review by the UCT's Technology Transfer Office (TTO).

In the second semester, the design approach moves to practical hands-on device development. The conceptual design developed in the first semester of the course is refined before it can be recommended for prototyping. The training includes selecting the consumables for the device, procurement, and dealing with external vendors. On successful laboratory bench testing of the device, suitable ethics approval is sought and the device is evaluated in a clinical setting. By the end of the semester, the student has been trained on converting a conceptual design into a tangible solution. The deliverables for the second semester include: 1. A design report on prototyping; 2. A bench test report; 3. An ethics application; 4. A clinical evaluation report; and 5. A working prototype of the proposed solution. The course ends with the demonstration of the working prototype in a suitable environment.

Clinician interaction platform

The clinician interaction platform is fundamental to the course. It is important in understanding the problem that needs a solution. The engagement of clinicians at an early stage serves to ensure their buy-in and create a working relationship for a long-term commitment to the project. The clinicians are carefully chosen based on their expertise in a particular field. They provide useful input in the identification of the problem, based on their clinical experience. Jones (2013) argues that it is the final users of medical equipment such as doctors and patients who are best positioned to innovate by first identifying the need for a novel device or for the improvement of an existing technology. At the University of Cape Town, there is no undergraduate programme in Biomedical Engineering. Instead, the students for the postgraduate programme are drawn from various non-medical backgrounds such as electrical and mechanical engineering as well as computer science. This means that those students possess the technical skills to design technologies but are not well

informed on medical problems that need solutions. This is the gap that in which the clinician interaction platform fills, by providing the clinical context.

Medical device product development

Once the problems have been identified by the clinicians, the next step is to assemble a group of experts. This group, referred to as a 'think tank', is made up of specialists from different backgrounds such as medicine, intellectual property rights, and industry, who, because of the nature of their work, are difficult to bring together. Cognisant of the time constraints of the think tank members, meetings take place quarterly and usually last for about 2–3 hours. To make the most of the meetings, four problems are presented at one sitting. The logic behind the think tank is to scrutinise the problems from different angles, assess needs, and generate ideas and conceptual solutions. The conceptual solutions are not real solutions per se, but suggest basic functionality to address the identified problems. This is done well in advance of the students starting the course and is an important phase of screening with the aim of designing minimum viable products. The outcomes from the think tank provide the entry points for the projects that the students will work on during the course. The students continue to interact with the clinicians throughout the course.

Each student is assigned a problem and a proposed solution which he or she is expected to work on for the 10 months of the course. During this period, the students interact with clinicians as they work towards solutions. They also attend lectures which provide engineering design support. The students engage in concept generation and screening and develop a strategy on how to design a medical device that addresses the identified challenges. Multiple solutions are generated and screened using constraints such as cost, time and manufacturing resources. Quality is an important parameter; as the students work within a small budget, an effort is made to ensure that the quality of the solution is not compromised by limited funds. Students are expected produce a tangible prototype that solves the challenge. Course assessment involves testing the prototype for functionality and usability.

Intellectual property management

The medical devices developed during the course are assessed for novelty and commercial viability, for which knowledge of intellectual property (IP) management and of the requirements for taking a medical device from the laboratory to the market, is important. To provide the students with such knowledge, they attend a workshop run by experts who take them through a journey covering the nature of IP, the different forms of IP, and invention disclosure.

The students learn how to distinguish between inventions that can be patented and those which cannot. They are taught how to search a patent database which is provided by the university. They

are also taught how to disclose inventions formally. Particular emphasis is placed on the following questions, towards filtering potential medical devices for patenting:

- What distinguishes your invention from existing technology, i.e. what are the improvements? Students are expected to provide a brief overview of existing, similar technology(ies).
- In what way is your invention ‘inventive’ or not obvious to people with your technical skills? Students are expected to describe any surprising effects or outcomes that could not have been predicted based on current understanding or theory.
- What possible extensions, variations or modifications are there for the device? This enables ongoing and future work to be accommodated in any patent specification.

Commercialisation strategy

The students are taken through different commercialisation strategies linked to intellectual property rights. The commercialisation strategies are a series of financing options that can be pursued in moving the technology/product from concept to market. The aim is not to prescribe a particular commercialisation strategy, but for the students to choose one that suits them. The strategies include start-ups, spin-off companies, licensing, and forming strategic partnerships.¹

Reimbursement and regulation

The students are exposed to the reimbursement and regulatory requirements for different territories². It is important for the students to know how medical devices are regulated so that they become aware of the steps to take if they wish to put their product on the market. The students learn about the procedures for certification with the South African Bureau of Standards and other regulatory bodies. They are exposed to the classification of medical devices based on their level of risk.

Another area that is given attention is reimbursement for medical devices, which deals with the logistics of who pays for the product; for example, reimbursement may be through insurance. With reference to South Africa, the students learn about the National Pharmaceutical Product Index code, which is a unique identifier for a given surgical or consumable product enabling electronic transfer of information throughout the healthcare delivery chain. The code is used as the standard for electronic information exchange for procedure and consultation claims.

¹ Commercialisation strategy options and implementation may differ in different countries. For more information, refer to the chapter “Intellectual Property Protection and Commercialisation” elsewhere in this book.

² For further information on medical device regulation, refer to the chapter “The regulation of medical devices in Africa” elsewhere in this book.

Public awareness

The students learn the importance of raising awareness of products that are ready to be taken to the market, and at the same time they learn to promote Biomedical Engineering as an area of scientific activity. They are exposed to different ways of showcasing their products, focusing on what the technology can do in comparison with existing devices. Raising public awareness takes various forms; these include radio and television shows, journal articles, exhibitions and public lectures. Examples of product communication to the public include:

- A video on a hand exoskeleton for stroke rehabilitation:
<https://www.youtube.com/watch?v=tiIOqoaP3jc>
- An article on an open-access ptosis crutch design:
http://www.rci.uct.ac.za/rcips/innovation_achievements/products/PtosisCrutch
- A lecture to inspire high school learners: http://tlabs.ac.za/?ai1ec_event=learners-lecture-dr-sudesh-sivarasu

Conclusion

The course on medical devices design prepares Biomedical Engineering students to develop medical devices that are appropriate to needs, at low cost. It takes into consideration the constraints which hinder technological development in low-income settings such as lack of funding, skilled personnel and infrastructure. By leveraging the skills of a pool of students drawn from different engineering backgrounds and the insights from clinical partners to develop medical devices, an interdisciplinary approach is applied to the problems being addressed. The course is intended to impart skills that will enable graduates to use technology to address public health challenges faced by developing countries, and ultimately to contribute to the growth of the local medical device industry.

References

- Abbott, F.M., Correa, C.M. & Drahos, P. 2013. *Emerging markets and the world patent order*. [Cheltenham, United Kingdom]: Edward Elgar Publishing.
- Borrás, C. 2017. *Defining the medical imaging requirements for a rural health center*. Singapore: Springer.
- Finch, L.C., Kim, R.Y., Ttendo, S., Kiwanuka, J.K., Walker, I.A., Wilson, I.H., Weiser, T.G., Berry, W.R. et al. 2014. Evaluation of a large-scale donation of Lifebox pulse oximeters to non-physician anaesthetists in Uganda. *Anaesthesia*. 69(5):445–451. DOI: 10.1111/anae.12632.
- Hobday, M. 2005. Firm-level innovation models: perspectives on research in developed and developing countries. *Technology Analysis & Strategic Management*. 17(2): 121–146.
<https://doi.org/10.1080/09537320500088666>.
- Jones, A. 2013. Medical equipment donated to developing nations usually ends up on the junk heap. *Scientific American*. Available: <https://www.scientificamerican.com/article/medical-equipment-donated-developing-nations-junk-heap/> [2019, May 1].

- Kaur, M., Hall, S. & Attawell, K. 2001. *Medical supplies and equipment for primary health care: a practical resource for procurement and management*. Coulsdon, United Kingdom: Echo International Health Services.
- Krishna, V.V., Waast, R. & Gaillard, J. 1998. Globalisation and scientific communities in developing countries. In *World Science Report 1998*. Paris: UNESCO. 273–287. Available: <https://unesdoc.unesco.org/ark:/48223/pf0000112616> [2019, May 2].
- KPMG. 2014. *Industry overview and economic impact assessment for the South African medical technology industry*. [Cape Town: South Africa.]: KPMG.
- Langergaard, L.L. & Hansen, A.V. 2013. Innovation – a one size fits all concept? *Proceedings: XXIV ISPIM Conference*, Helsinki.
- Lorentzen, J. & Mohamed, R. 2010. ... to each according to his (or her) needs: Where are the poor in innovation studies? *Proceedings of the Innovation for Development: Frontiers of Research, Policy and Practice Symposium, 2010*. Johannesburg: University of the Witwatersrand. Available: <http://repository.hsra.ac.za/bitstream/handle/20.500.11910/4037/6578.pdf?sequence=1> [2019, May 2].
- SAMED. 2014. *The South African medical device industry – facts*. Available: <http://www.samed.org.za/DynamicData/LibraryDownloads/224.pdf> [2019, May 2].
- Sodhi, K., Talati, S., Gupta, A.K. & Arora, P. 2014. Equipment donation: a perspective from a teaching tertiary care hospital in North India. *Indian Journal of Scientific Research*. 8(1):112–114.
- Tödtling, F. & Trippel, M. 2005. One size fits all?: towards a differentiated regional innovation policy approach. *Research Policy*. 34(8):1203–1219. DOI: 10.1016/j.respol.2005.01.018.
- WHO. 2000. *Guidelines for health care equipment donations*. Geneva: World Health Organization. Available: https://www.who.int/medical_devices/publications/en/Donation_Guidelines.pdf [2019, May 20].
- WHO. 2010a. *Landscape analysis of barriers to developing or adapting technologies for global health purposes*. Geneva: WHO. Available: <http://apps.who.int/medicinedocs/documents/s17778en/s17778en.pdf> [2019, May 2].
- WHO. 2010b. *Barriers to innovation in the field of medical devices: Background paper 6*. Geneva: WHO. Available: <http://www.who.int/iris/handle/10665/70457> [2019, May 2].
- WHO. 2011. *Medical device donations: considerations for solicitation and provision*. Geneva: WHO. Available: http://apps.who.int/iris/bitstream/10665/44568/1/9789241501408_eng.pdf [2018, February 18].
- WHO. 2017. *Human resources for medical devices – The role of biomedical engineers*. Geneva: WHO. Available: <http://apps.who.int/iris/bitstream/handle/10665/255261/9789241565479-eng.pdf;jsessionid=8CE3A3FCA0515666B5DC01AAF1C0A258?sequence=1> [2019, May 2].

Chapter 9

Materials for Medical Devices

T. Saidi, A.A. Dare, S.K. Fasogbon, O. Ewemoje, O. Anyaeche,
M. Bolarinwa, O. Adetoyi, K. Adewole, O. Lawal & A.O. Coker

Introduction

The selection of suitable materials is a crucial step in medical device design and influences the safety and performance of medical devices. It should be done during the early phases of product development, particularly when the functional requirements of the device are assessed (Pietzsch et al., 2009; Allen, 2018). Materials selection is based on the appropriateness of the materials in terms of design flexibility, cost-effectiveness, product safety, quality, and performance (Shang & Woo, 1996). This chapter discusses the considerations in choosing suitable materials for medical devices, highlights the challenges faced in Africa with regard to medical device materials, and provides recommendations on the way forward.

Selection of materials

The selection of medical device materials demands an understanding of the materials with particular focus on attributes ranging from physical performance and manufacturing constraints, to budget limitations and supply chain logistics (Ramesh & Sivaramanarayanan, 2013; Hurlstone, 2018). Normally, the selection starts with a wide choice which is trimmed down to two or three candidates which are subjected to testing in order that informed choices can be made (Choi, Kim & Ha, 2008; Ramesh & Sivaramanarayanan, 2013). A set of selection criteria should be defined to guide the process (Choi et al., 2008).

Material properties

A wide range of materials is used in the manufacture of medical devices. The materials include metals, ceramics, polymers, and composites, and they can be used singly and in combination (Batchelor & Chandrasekaran, 2004; Patel & Gohil, 2012). The selection of materials is not only based on their ability to perform the intended functions, but also their ability not to initiate side effects such as damaging the surrounding tissue, in cases where the devices are implanted or come into close contact with the body, or inducing a wider health problem. This demands a circumspect consideration of different parameters to decide whether or not a material and at a particular grade is appropriate for use in a medical device (Bhat & Kumar, 2013). According to Allen (2018), three areas should be emphasised when selecting materials, namely, device needs and regulations; application and performance; and manufacturing and costs. These three areas embrace several

categories which are not limited to the material only, but to decision making such as innovating versus using available choices, and building versus buying. Typically, the selection of materials is based on functionality and biological and chemical attributes (Geddes & Roeder, 2003).

Mechanical properties of materials need to be considered when selecting materials for medical devices. The ability of a material to withstand mechanical forces such as its tensile strength, fracture hardness, elasticity modulus, and fatigue resistance, must be considered (Lantada & Morgado, 2013). For example, rigid plastic materials are typically used for components such as housings, fittings, fasteners, and connectors because of their strength and stiffness (Larson, 2016). Engineered thermoplastics can withstand low and high temperatures which render them suitable for applications where changes in temperature may influence outcomes (Ramesh & Sivaramanarayanan, 2013). Metals are used in implants and prostheses for their mechanical properties and particularly for their high static and dynamic strength (Lantada & Morgado, 2013). Nanomaterials are emerging as good candidates for orthopaedic devices (Ying, 2001; Bhat & Kumar, 2013).

Examples of materials that are suitable for specific biomedical applications, include polymers used as implant material for cardiovascular applications such as vascular grafts, stents, prosthetic heart valves, catheters and heart assist devices (Jaganathan et al., 2014). Their suitability for these applications results from their biocompatibility, which makes them preferable to metallic biomaterials (Helmus & Hubbell, 1993). Heart valves are manufactured mainly from polyurethane material which is formulated and optimised to exhibit the desired chemical (degradation resistance, non-toxicity) and mechanical (strength and toughness, flex life, elasticity) properties (Saidi & Douglas, 2016).

Titatum alloys are widely utilised for metallic orthopaedic implants due to their light weight, superior biocompatibility, low stiffness and low cost (Buechel & Pappas, 2015). Hydrogels made from the cross-linking of natural and synthetic hydrophilic polymers to resemble living tissue, are mainly used in the manufacture of contact lenses, tissue engineering scaffolds, drug delivery systems, hygiene products and wound dressings (Caló & Khutoryanskiy, 2015). This is because they possess unique attributes such as high water content, softness, flexibility and biocompatibility.

A key question to consider in the selection of the materials for that come into contact with body tissues such as implantable devices is how they will perform inside the body, which is very sensitive to foreign objects (Batchelor & Chandrasekaran, 2004). When selecting materials for such devices, emphasis should be on biological factors (Lantada & Morgado, 2013). Consideration of biocompatibility is important in establishing the ability of a particular material to be in contact with tissues of the human body without causing unacceptable harm (Geetha et al., 2009). It is imperative that the material not adversely affect the host environment of interaction such as bone and soft tissues, plasma composition, as well as intra and extracellular fluids (Patel & Gohil, 2012). Materials used for medical devices which involve body contact should be chemically stable, biocompatible,

safe, non-carcinogenic, non-toxic, non-allergenic and non-inflammatory (Lantada & Morgado, 2013). The focus of biocompatibility, however, is not simply on the ability of the material to remain inert in the body, but its ability to perform a function in the body (Patel & Gohil, 2012).

Corrosion resistance is an important parameter in the selection of metallic implants because contact with corrosive body fluid is inevitable (Singh & Dahotre, 2007). Chemical reactions due to corrosion can adversely affect implant devices, for example dissolved metal ions can accumulate in tissues, near the implant or they may be transported to other parts of the body causing harm to the body (Patel & Gohil, 2012). The materials used for medical implants require a careful assessment of how they respond to tissues to address safety and functionality concerns, as implant-associated protein adsorption and conformational changes can invoke immune reactions. Protein adsorption and cell interactions may be addressed through engineering of surface properties to improve implant biocompatibility (Tang, Thevenot & Hu, 2008).

Regulation

To ensure compliance with good quality assurance practices, it is necessary to consider the regulations governing the use of the materials for medical devices (Leuschrier, 1992; Ying, 2001). In general, the medical device industry is highly regulated and compliance with regulatory standards is a basic requirement.¹ Adherence to regulatory standards for the materials used in medical devices often marks the difference between success and failure in medical device design (Lantada & Morgado, 2013). There are international standards which focus specifically on the materials used in medical devices; these include ISO Standard 10993 for biological evaluation of medical devices and the ISO 9000 series on quality and procedures (Young, 1994; Kotzar et al., 2002). These standards are useful in the selection of materials for medical devices as they facilitate objective comparisons of possible alternatives and provide guidance in choosing reliable suppliers.

Manufacturing and processing requirements

Materials for medical devices are produced in various ways; these range from traditional processes such as milling, turning and shaping, to more recently introduced techniques such as additive manufacturing. Additive manufacturing converts 3D digital models into 3D objects by constructing them layer by layer under computer control (Douglas, 2014). One example of this kind of manufacturing technology is 3D printing. The technologies available for manufacturing, the costs involved, and the skills needed to produce the materials, impact on the choice of materials for medical devices.

¹ For further information on medical device regulation, refer to the chapter “The regulation of medical devices in Africa” elsewhere in this book.

Challenges in Africa

A medical device industry in Africa is largely absent resulting in over-reliance on imports from foreign companies (De Maria, Mazzei & Ahluwalia, 2015). This, combined with limited academic programmes in biomedical engineering in most African countries, results in limited research and development activity in biomedical engineering in general, and also in materials for medical devices in particular. Thus, local medical device development for local needs in Africa may still rely on imported materials, and would face barriers such as the costs of importation, and an inability to experiment due to lack of easy access to materials.

Only a few African countries have developed regulations on medical devices. Mori, Ravinetto, and Jacobs (2011) argue that there is poor regulatory oversight of medical devices in resource-limited settings, resulting in the proliferation of counterfeit and sub-standard products on the market. South Africa, which is one of the leading countries in medical device development in sub-Saharan Africa, had no dedicated regulations on medical devices until 2015 (Saidi & Douglas, 2018). In the absence of regulations, most African countries do not have checks and balances that guide the selection of materials for medical devices.

Due to limitations in technological development, many African countries face challenges in accessing modern manufacturing techniques for materials. Many novel materials with high strength, light weight, and greater chemical resistance such as nanomaterials and nanotubes have come into existence due to developments in the field of nanotechnology (Ezema, Ogbobe & Omah, 2014). However, most African countries are lagging behind in adopting emerging technologies (Akpan, 2014). Such constraints adversely affect medical device development, since innovators and manufacturers interested in the use of emerging materials such as nanomaterials, and emerging technologies, such as additive manufacturing, do not have access to the required facilities.

In sub-Saharan Africa, South Africa has embraced the potential of 3D printing to revolutionise manufacturing systems, while other countries are following the path of late adopters (Campbell, De Beer & Pei, 2011). In combination with open source designs, 3D printing can improve the ability of low-resource countries to produce medical devices. For instance, researchers at University of Cape Town have developed a 3D printable medical device and released the design as an open source innovation which can be downloaded at no cost (Saidi, Sivarasu & Douglas, 2018). The device, shown in Figure 1, a modular, adjustable ptosis crutch for elevating the upper eyelid in patients with myasthenia gravis, a condition for which treatment options are limited in low-resource settings.



Figure 1: 3D-printed ptosis crutch, described in Saidi, Sivarasu and Douglas, 2018, attached to spectacles.

The way forward

To address the challenges faced by African countries in the development and use of suitable materials for medical devices, there is need to foster a culture of collaboration in the field of biomedical engineering to pool limited resources. The initiative by the African Biomedical Engineering Consortium for capacity building through enhancing biomedical engineering research and teaching capacity at universities in Africa is a good example of how health technology competencies that address the needs of Africa can be developed (Douglas et al., 2017). The development of materials for medical devices in Africa can benefit from pooling of the available physical, human and financial resources on the continent. The development of national systems of innovation such as nanotechnology innovation centres in South Africa (Albuquerque et al., 2015) for research and development of nanostructured materials and their applications by researchers across the continent is an example of how infrastructural challenges can be addressed. The innovation centres provide platforms to develop local materials that are customised to meet the needs of local users.

Regulations to guide the manufacture of, and the selection of materials for, medical devices, are necessary to promote product safety. African countries should invest in developing and reinforcing national regulatory oversight on medical devices. They should embrace new technologies such as 3D printing, which is providing tools for the manufacture of materials that were once the exclusive prerogative of a few companies and has the potential to accelerate the design and manufacture of medical devices in low income settings.

References

- Akpan, P.U. 2014. Nanotechnology status in Africa (1995–2011): a scientometric assessment. *1st African International Conference/Workshop on Applications of Nanotechnology to Energy, Health and Environment*. Available: <http://nanotechunn.com/proceedings/Nanocon314-24%20Akpan%20-%20Nanotechnology%20Status%20in%20Africa.pdf> [2019, May 9].
- Albuquerque, E., Suzigan, W., Kruss, G. & Lee, K. 2015. *Developing national systems of innovation: university–industry interactions in the Global South*. Cheltenham, UK: Edward Elgar Publishing.

- Allen, D. 2018. The future is here: what's new and exciting in medical materials. *Medical Device and Diagnostic Industry*. Available: <https://www.mddionline.com/future-here-whats-new-and-exciting-medical-materials> [2019, May 9].
- Batchelor, A.W. & Chandrasekaran, M. 2004. *Service characteristics of biomedical materials and implants*. London: Imperial College Press.
- Bhat, S. & Kumar, A. 2013. Biomaterials and bioengineering tomorrow's healthcare. *Biomatter*. 3(3):e24717. DOI: doi.org/10.4161/biom.24717.
- Buechel, F. F. & Pappas, M. J. 2015. *Principles of Human Joint Replacement: Design and Clinical Application*. New York: Springer.
- Caló, E. & Khutoryanskiy, V.V. 2015. Biomedical applications of hydrogels: A review of patents and commercial products. *European Polymer Journal*. 65:252-267.
- Campbell, R.I., de Beer, D. & Pei, E. 2011. Additive manufacturing in South Africa: building on the foundations. *Rapid Prototyping Journal*. 17(2):156-162.
- Choi, M.-C., Kim, Y. & Ha, C.-S. 2008. Polymers for flexible displays: from material selection to device applications. *Progress in Polymer Science*. 33(6):581-630. doi.org/10.1016/j.progpolymsci.2007.11.004.
- De Maria, C., Mazzei, D. & Ahluwalia, A. 2015. Improving African healthcare through open source biomedical engineering. *International Journal on Advances in Life Sciences*. 7(1):10-19.
- Douglas, T.S. 2014. Additive manufacturing: from implants to organs. *South African Medical Journal*. 104(6):408-409. Available: http://www.scielo.org.za/scielo.php?pid=S0256-95742014000600015&script=sci_arttext&tlng=pt [2019, May 9].
- Douglas, T.S., Haile, D.A., Atwine, D., Karanja, Y., Madete, J., Osuntoki, A., Rushdi, M., Ahluwalia, A. et al. 2017. Building needs-based healthcare technology competencies across Africa. *South African Journal of Science*. 113(7-8):5. Available: https://issuu.com/sajs/docs/volume_113_issue_7-8__11mb__issuu [2019, May 9].
- Ezema, I.C., Ogbobe, P.O. & Omah, A.D. 2014. Initiatives and strategies for development of nanotechnology in nations: a lesson for Africa and other least developed countries. *Nanoscale Research Letters*. 9(1):133. DOI: doi.org/10.1186/1556-276X-9-133.
- Geddes, L. A. & Roeder, R. 2003. Criteria for the selection of materials for implanted electrodes. *Annals of Biomedical Engineering*. 31(7):879-890.
- Geetha, M., Singh, A., Asokamani, R. & Gogia, A. 2009. Ti based biomaterials, the ultimate choice for orthopaedic implants—a review. *Progress in Materials Science*. 54(3):397-425. DOI: doi.org/10.1016/j.pmatsci.2008.06.004.
- Helmus, M.N. & Hubbell, J.A. 1993. Materials selection. *Cardiovascular Pathology*. 2(3):53-71.
- Hurlstone, C. 2018. *Selecting materials for medical devices*. Available: <https://www.team-consulting.com/insights/selecting-materials-for-medical-devices/> [2019, May 9].
- Ikada, Y. 2002. Biological materials. In *Integrated biomaterials science*. R. Barbucci. Ed. Boston, MA: Springer. 1-23.
- Jaganathan, S.K., Supriyanto, E., Murugesan, S., Balaji, A. & Asokan, M.K. 2014. Biomaterials in cardiovascular research: applications and clinical implications. *BioMed Research International*. 2014: Article ID 459465. <http://dx.doi.org/10.1155/2014/459465>
- Kotzar, G., Freas, M., Abel, P., Fleischman, A., Roy, S., Zorman, C., Moran, J.M. & Melzak, J. 2002. Evaluation of MEMS materials of construction for implantable medical devices. *Biomaterials*. 23(13):2737-2750. DOI: [doi.org/10.1016/S0142-9612\(02\)00007-8](https://doi.org/10.1016/S0142-9612(02)00007-8).

- Lantada, A.D. & Morgado, P.L. 2013. General considerations for the development of biomedical devices. In *Handbook on advanced design and manufacturing technologies for biomedical devices*. A.D. Lantada, Ed. Madrid: Springer. 19–45.
- Larson, E. 2016. Plastics selection for medical wearables: an overview. *Med Device Online*. Available: <https://www.meddeviceonline.com/doc/rigid-plastics-selection-for-medical-device-design-part-0001> [2019, May 9].
- Leuschrier, J. 1992. Legal requirements for the preclinical toxicological evaluation of biomaterials. *Clinical Materials*. 10(1–2):51–57. DOI: [doi.org/10.1016/0267-6605\(92\)90085-8](https://doi.org/10.1016/0267-6605(92)90085-8).
- Mori, M., Ravinetto, R. & Jacobs, J. 2011. Quality of medical devices and *in vitro* diagnostics in resource-limited settings. *Tropical Medicine & International Health*. 16(11):1439–1449. DOI: doi.org/10.1111/j.1365-3156.2011.02852.x.
- Patel, N.R., & Gohil, P.P. 2012. A review on biomaterials: scope, applications & human anatomy significance. *International Journal of Emerging Technology and Advanced Engineering*. 2(4): 91–101.
- Pietzsch, J.B., Shluzas, L.A., Paté-Cornell, M.E., Yock, P.G. & Linehan, J.H. 2009. Stage-gate process for the development of medical devices. *Journal of Medical Devices*. 3(2):021004. Available: https://www.researchgate.net/profile/Lauren_Shluzas/publication/262375810_Stage-Gate_Process_for_the_Development_of_Medical_Devices/links/004635377add29567b000000.pdf [2019, May 9].
- Ramesh, A. & Sivaramanarayanan, K. 2013. An overview of the plastic material selection process for medical devices. White paper. Available: https://www.hcltech.com/sites/default/files/an_overview_of_the_plastic_material_selection_process_for_medical_devices.pdf [2019, May 9].
- Saidi, T. & Douglas, T. 2018. Medical device regulation in South Africa: The Medicines and Related Substances Amendment Act 14 of 2015. *South African Medical Journal*. 108(3):168–170. Available: http://www.scielo.org.za/scielo.php?pid=S025695742018000300011&script=sci_arttext&tlng=pt [2019, May 9].
- Saidi, T., Sivarasu, S. & Douglas, T. S. 2018. Open source modular ptosis crutch for the treatment of myasthenia gravis. *Expert Review of Medical Devices*. 15(2):137–143. DOI: doi.org/10.1080/17434440.2018.1421455.
- Shang, S. & Woo, L. 1996. Selecting materials for medical products. *Medical Device and Diagnostic Industry*. 18(10):132.
- Singh, R. & Dahotre, N.B. 2007. Corrosion degradation and prevention by surface modification of biometallic materials. *Journal of Materials Science: Materials in Medicine*. 18(5):725–751. DOI: [10.1007/s10856-006-0016-y](https://doi.org/10.1007/s10856-006-0016-y).
- Tang, L., Thevenot, P. & Hu, W. 2008. Surface chemistry influences implant biocompatibility. *Current Topics in Medicinal Chemistry*. 8(4):270-280.
- Ying, J.Y.-R. 2001. *Nanostructured materials*. San Diego: Academic Press.
- Young, A.L. 1994. An overview of ISO 9000 application to drug, medical device, and environmental management issues. *Food & Drug Law Journal*. 49:469. Available: https://heinonline.org/HOL/Page?handle=hein.journals/foodlj49&div=44&g_sent=1&casa_token=&collection=journals&t=1557406579 [2019, May 9].

Part 3

Design Case Studies

Chapter 10

User-Centred Design in a Health Innovation Course to Address Hearing Loss in the Elderly

N. Conrad, T.E.M. Mutsvangwa, A. Doyle, T. Saidi & T.S. Douglas

Introduction

South Africa, like many other developing countries, faces challenges in the delivery of healthcare. The prevalence of acute and chronic diseases, the persistence of infectious diseases, and the rise of non-communicable diseases spanning all age groups present challenges for an overburdened public healthcare delivery system (Chopra et al., 2009; Mayosi et al., 2009). Lack of financial resources is a major impediment (Levitt et al., 2011). In such an environment, suitable low-cost solutions are imperative. It is against this background that we introduced a course on Health Innovation and Design at the University of Cape Town.

The Health Innovation and Design course aims to equip students with the tools to design and evaluate context-appropriate interventions to improve health. The course is anchored in design thinking (Brown, 2008), a methodology that cuts across disciplinary boundaries. The course is primarily attended by students enrolled for master's degrees in health innovation and in biomedical engineering and is open to students holding any four-year degree who have an interest in health innovation. Thus, it draws students from different disciplines, who are able to contribute diverse disciplinary knowledge, gained in a range of undergraduate degrees.

This chapter demonstrates and assesses the implementation of design thinking as a means to facilitate and promote health innovation in the Health Innovation and Design course.

Design thinking

Design thinking is premised on a reciprocal relationship between the end-user and the design thinker (Goldman, 2016). In this approach, in-depth research-based learning is implemented as a form of contextual and cultural immersion to meet the needs of the end-user/community (Renard, 2014; Schweitzer, 2015; Goldman, 2016). An important aspect of design thinking is the development of empathy as a way of fostering participation and engagement. Account is taken of socio-economic conditions and cultural differences and effort is made to understand the experiences of consumers (Brown, 2008). Thus design thinking is practiced within the user's experiences rather than the ideals of the expert (Tideholm & Rydén, 2015). It is a holistic and human-centred approach informed by interdisciplinary collaboration, prototyping, feedback and iteration (Renard, 2014; Goldman, 2016).

Design thinking toolkit

Supporting the design thinking mindset is a set of methodological techniques that are grounded in co-creation, collaboration and iteration (Tideholm & Rydén, 2015). Co-creation involves a number of stakeholders, ranging from academics/researchers to healthcare professionals and patients in addressing complex problems. Collaboration in an interdisciplinary team is vital to the learning experience to foster deep learning through the exchange of ideas with peers (Goldman et al., 2014). The notion of iteration enables learning through “real work experimentation” where students test their ideas, get feedback and use the feedback to further develop their solutions (Tideholm & Rydén, 2015).

Various organisations have implemented design thinking, e.g. IDEO (Ideo, 2017) and the Stanford Design School (Stanford University. Hasso Plattner Institute of Design, 2017). Different toolkits of design thinking use three, four or even five phases, all of which fall into three central categories (Tideholm & Rydén, 2015). First, there is an exploratory phase, wherein data collection occurs to enable understanding of the context, the people and their needs. Second, ideation is the formation of ideas for finding innovative opportunities to meet the needs of users. Lastly, ‘iterative prototyping’ entails testing and receiving feedback on the ideas (Tideholm & Rydén, 2015). Some toolkits may divide these three categories into more phases. We focus on the Philips Co-create Four-Phase Design Process (Philips, 2016). The Philips toolkit explains this method as a creative, iterative, multidisciplinary approach to innovation and problem solving in a people-centric way. This toolkit divides the exploratory phase into the Discover and the Frame phases. The Ideation phase follows. Prototyping and testing are referred to as the Build phase.

Data collection takes place in the Discover phase; observations, information, and insights are collected from various stakeholders and categorised into themes. This phase is used to understand the context, the people and their needs, as well as to build empathy (Tideholm & Rydén 2015). Various techniques are used to collect data such as structured or semi-structured interviews and observations. The observation may entail immersion of the researcher in the context of the phenomenon being studied, allowing the researcher to document their experiences as a reflexive exercise while gaining insight from the environment (Ritchie, 2003). The data is presented in a Journey map where key insights are identified (Philips, 2016).

The Frame phase uses the data collected to define a clear need or opportunity (Philips, 2016). This opportunity or need is formulated into a vision statement to represent the needs of the users as interpreted by the team.

The Ideation phase is where possible solutions are generated to the vision statement defined in the Frame phase; the group selects the most feasible ideas and expands on how these can be achieved. Collaboration between students from various backgrounds facilitates the development of diverse ideas (Philips, 2016).

The Build phase requires ‘iterative prototyping’ which is subject to testing and feedback and informs a process of rediscovery (Tideholm & Rydén, 2015). Tangible but low-fidelity prototypes are constructed and presented to stakeholders to communicate solution ideas and gather feedback. Presentations and role-play may be used to convey the ideas.

In each of the four phases, the input of the end-users plays a central role and the desirability of the intended solution to the end-user is always foregrounded. These phases are depicted in Figure 1.

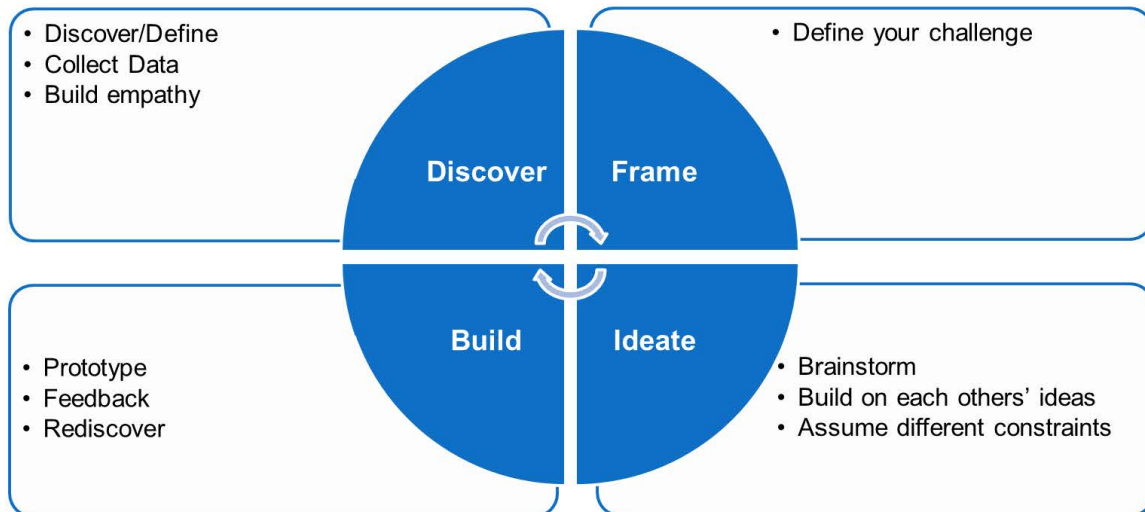

Figure 1: Four phases of Design Thinking (adapted from Philips, 2016).

Implementation of the course

The Health Innovation and Design course was first implemented over two semesters in 2015. Our first cohort of students consisted of a PhD student in human genetics, a master’s student in occupational therapy, a PhD student in speech therapy and four master’s students in biomedical engineering. In the first semester students were given formal lectures on design thinking and participated in a preliminary design challenge as a means of embedding the design thinking approach. They completed weekly learning logs which formed the basis of a final report. In the second semester, they were given the design challenge of addressing hearing loss in the elderly using the design thinking techniques that had been introduced the first semester. The community partner in this instance was an NGO providing housing and services to the elderly. The sections that follow describe the second-semester implementation.

Discover phase

After the students’ introduction to the initial design challenge, which was to address the needs of the hearing-impaired for improved assistive devices, their first activity was to explore their personalised interpretations of the challenge. Since the students were from different academic

backgrounds, it was envisaged that the challenge would invoke different meanings. The students shared their emotions, biases, assumptions and prejudices related to the design challenge. The exercise enabled the students to appreciate the diversity of views and the richness emanating from multi-disciplinary teams. Team work would require them to have a shared meaning of the challenge from the outset.

Having done the groundwork of exploring the initial design challenge and identifying the stakeholders, the students engaged the project partner, the head of health at the NGO, for a brief introduction to the context of the challenge. To prepare students for their interactions with the residents, the class was addressed by a social anthropologist with experience in working with the hearing impaired and profoundly deaf people. The students were then ready to gather information on the initial design challenge, through observation and interviews. The interviews were semi-structured to enable flexibility in exploring interesting insights. The students interviewed residents and nurses of the NGO residential facility.

The questions posed to the residents were related to their age, how long they had lived at the NGO, how independent they were, their level of literacy, what their typical day was like, what they did for fun, what medical conditions they had, how long they had had hearing loss, what they found troublesome with hearing aids if they used them, and what it was like to live with hearing loss. Questions to the nurses were related to how residents were identified for hearing loss, and what it was like to deal with residents whose hearing was in decline. Students also interviewed an elderly person with a hearing aid, who was not part of the community supported by the NGO, in order to gain complementary insights from someone who had adapted to living with a hearing aid. This data collection was accompanied by a literature review on hearing loss in the elderly.

The students developed four major themes for the design challenge namely denial about hearing loss, lack of awareness of hearing loss by the residents, stigma, and the effect of the environment on hearing. These themes are in line with a study on hearing loss in the elderly by Wallhagen (2009), in which some participants noted the irrelevance of stigma, but still argued that it did exist, while others noted that the hearing aids were too visible and they did not want to be labelled as handicapped, noting that certain people “recoil” from physical or mental disability. It has been shown that in older adults who have already formed their self-identity, it is much more difficult to accept a diagnosis of hearing loss as part of who they are (Amieva, 2015). Participants in the study by Wallhagen (2009) did not want to acknowledge that they were becoming weaker and considered hearing aids a sign of aging. The reported findings echo responses of participants in our study. Interviewees also revealed that it was difficult to follow conversations in noisy and crowded environments.

Conversations with the nurse at the NGO clarified the referral process for obtaining hearing aids. The students learned that because hearing loss was not sufficiently acknowledged by the elderly, the affected residents would not identify themselves as candidates needing intervention. Therefore,

interventions were not received when needed, often resulting in a postponement in addressing the hearing problem with a healthcare practitioner. The vast majority of residents were still very active, independent and self-sufficient individuals who were generally literate. They may not have considered hearing loss a major health problem compared to other more life-threatening challenges such as heart disease and diabetes, as participants felt that they could manage their routine with diminished hearing.

The students used a journey map (Figure 2) (Komninos, 2019) also known as an experience flow (Philips, 2014) to describe an experience from a user's perspective by examining what they are doing, thinking and feeling, and to identify high points and low points of their activities. The "Key Activities" may be easier to articulate as these are observable or may be clearly expressed by the user. "Think" and "Feel" may have to be inferred as users may not clearly express their feelings and perceptions. The assumptions made in completing the journey map are evaluated and tested at the build phase where the prototype is tested. The low points present opportunities for further exploration by improving negative experiences, while positive experiences may be emphasised or enhanced.



Figure 2: Journey map template (Philips, 2014).

Key activities are entered under "Do", while "Think" and "Feel" are inferred by the person completing the journey map from the information provided by the user. "Stakeholder B" is any stakeholder with whom the user interacts.

Frame phase

Following the Discover phase, where the data collected during the interviews and observations had been synthesised and discussed, a vision statement was created. This activity helps refocus the findings and thereafter new framed challenges are developed to guide the group's creativity.

The vision statement is an important step to ensure that consensus is reached on the most important challenge for the users. The vision statement created by the students was:

Improving the attitude towards and acknowledgement of hearing loss – making hearing loss more socially acceptable and highlighting the importance of screening.

Improving quality of life – adjusting a contained environment to improve hearing.

The framed challenges were:

- “How do we promote the acceptance of hearing loss?”
- “How do we promote the understanding of hearing loss?”
- “How do we disguise hearing aids?”
- “How do we promote the use of assistive devices and other solutions”
- “How do we adjust the contained environment (i.e. indoors where the environment is more predictable) to be more conducive to communication?”

The “patient-centeredness” (Santos, 2014) that is essential to effective health innovation is highlighted in the frame phase.

Ideate phase

During ideation, the solution space is expanded by generating as many ideas as possible that could help in solving the new framed challenges in an innovative way. The students grouped and rearranged many of their ideas, then also carried out a vetting process, which is part of the design thinking methodology. The students completed an “idea template” (Figure 3) which took into consideration what resources were required and which stakeholders' input would be required for the ideas to be implemented. This activity gives the students the opportunity to consider the critical function of the idea and what is needed to make it a reality. They then rated these ideas according to user needs and likelihood of implementation. They decided to retain four of their final solutions as they were unwilling to discard ideas, because they wanted to show the users their work hoping that these solutions might be beneficial.

IDEA Template

Idea <i>Catchy name and tagline</i> “Check Me Out/ Feel Good”	
What is it? <i>Describe the key principle of the idea</i> <ul style="list-style-type: none"> • Health promotion • Screening for health problems – emphasis on hearing loss / health screening • Providing access to appropriate treatment for health problems 	
Why is it a good idea? <i>Explain the benefits and added value for key customer</i> <ul style="list-style-type: none"> • Identify health problems among NGO residents • Identify health problems common in this elderly community • Provide access to appropriate treatment/ advice for identified problems • Let residents know that NGO is taking care of them • Position NGO as hub for screening with services available to external users • Improve quality of life for NGO individuals 	
How does it work? <i>Explain the ecosystem of stakeholders and touch points</i> <p>Healthcare providers will have various testing stations, each with its own speciality. Audiology and hearing screens will be embedded in a range of health tests. Referral processes can be activated if the health care provider cannot assist. Additionally, private companies could exhibit products such as hearing aids.</p>	What is needed for success? <i>Describe which key factors and capabilities are needed to make this real</i> <ul style="list-style-type: none"> • Funding • Co-operation from participants and healthcare professionals • Ability to address typical health problems, eg <ul style="list-style-type: none"> • Hearing loss • Blood pressure • Headache • Arthritis

Figure 3: Example of an idea template completed by students after their initial ideation round (adapted from Philips, 2014).

Ultimately, the students selected ideas targeted at promoting an understanding and acceptance of hearing loss and adjusting the environment to be more conducive to communication. The first idea (and the one depicted in Figure 3) was a “Health Awareness Day”, at which multiple health conditions would be tested, with the inclusion of hearing screening. This would counter the denial and stigma that might be associated with a specific hearing screening day. Sufficient medical information would be available for the residents to learn about hearing loss and assistive devices in addition to general medical information. The second idea, an “Acoustic Audit”, would aim to improve the acoustics of the living areas of the residents in order to improve their hearing without relying on assistive devices. Rather than putting the responsibility of carrying a device on a person who has hearing difficulty, the students preferred to make their living environment more suitable for effective communication. This would compensate for the reluctance of the elderly to seek medical advice and wear assistive devices such as hearing aids.

Build phase

Having generated potential solution ideas during the ideation, the students moved to the Build phase. Since the solutions were non-physical in nature, a conventional touch-and-feel prototype was not appropriate. The students presented their ideas to the residents of the NGO and other

invited stakeholders and guests in the form of a skit to demonstrate the need for self-diagnosis of hearing loss as well as the need for emotional support. To demonstrate the need for an acoustic audit of the environment, the group showed how different materials change the acoustics of the room. They received positive feedback from the audience overall. One invited guest, who was external to the class and the NGO, but had an interest in innovation and was in a similar age group as the elderly participants, appreciated that the solutions were not focused on individuals with the hearing loss, but rather on the environment and general activities to improve their quality of life.

Student assessment

Two methods of assessment were used to evaluate the students' understanding of the course material and the solutions they had produced. First, the students were required to present their chosen solution formally to the various stakeholders and end-user participants. The presentations allowed the students to describe briefly the design thinking process and its importance in health innovation. More importantly, the presentation formed part of the iterative process of improving solutions based on the feedback from the stakeholders. The students also presented to interdisciplinary intermediaries namely medical practitioners, academics and healthcare providers prior to the final presentation; this helped them refine their ideas. The final presentations were graded on creativity and effectiveness of communication to the audience.

The students were also required to write a report, which included a critical reflection on the design thinking theory covered in the course and the outcomes of the innovation process. Similar to the presentation, the report was used to gauge the students' understanding of the course material. More significantly, their critical reflection on the innovation process provided useful insights into the limitations and benefits of the techniques, how well the students adopted the design thinking mindset, and the effectiveness of the delivery of the material by the facilitators. Ultimately, the report assessed whether or not their understanding of the design process had significantly changed through interacting with the end-user.

In line with university quality assurance requirements, a suitably qualified and experienced external examiner was appointed to moderate the course assessments and attend the presentation of the solutions.

Student experiences

One of the students' most important realisations was that they had gone to the interviews with their own assumptions; such as "hearing loss is big a problem," "hearing aids are big and uncomfortable", "there is a stigma associated with wearing hearing aids", and "hearing aids are expensive". They learned that the reality was slightly different. They discovered that many of the difficulties related to communication and hearing were of environmental origin and that there was denial about

hearing loss. Their interactions did however confirm the stigma associated with wearing hearing aids.

After the first phase of design thinking where students attempted to observe and understand the elderly residents, they had already realised the benefits of truly engaging with their 'clients' in a meaningful way. At this point, they realised that a technological intervention, such as an assistive device, would probably not be the most appropriate intervention for the clients. The students reported that they had experienced empathy through engagements that centred on the users and that this had changed their views on what an appropriate solution might be.

The students noted that when they tried to ideate towards a solution for the hearing impaired, they would often realise that the broader special needs community may benefit as well. Another interesting observation was that those students who missed the interviews had a different perception of what the underlying problems of the elderly might be. For example, the students who conducted interviews became aware how important their appearance was to the residents, whereas others, who did not have first-hand experience with the residents, considered appearance a minor concern. Kilko (2015) argues that empathy allows the observers to use the behaviours of the people under inquiry to draw on emotive language that ultimately informs the observers' conclusions.

One student had been a software engineer before enrolling for his masters' degree and had many times created products for clients which the latter ultimately did not like. After a client would reject a product, it was a common in the company to proclaim that the "client does not know what he/she wants." Having completed the Health Innovation and Design course, the student realised that the company might not have understood the clients' needs. He now refers to himself as "a systems engineer with a changed mind-set about clients, requirements analysis, product design and delivery." In general, students reported that design thinking had changed the way they see problems and provided them with a novel way of finding solutions.

Conclusion

We have shown in this chapter that design thinking, by virtue of being user-centred, can be harnessed effectively to engender empathy and an appreciation of context during the development of health innovations. The positioning of the user/client at the centre of product and service development is crucial to understanding health problems through the lens of those affected. By involving the users in finding solutions, design thinking makes the user experience accessible to the students working on a challenge, thereby allowing them to conceive of designing experiences rather than designing services or products. The use of multi-disciplinary teams in solving challenges provides access to diverse experiences and skill sets. To enhance the effectiveness of design thinking as an approach to problem solving, reflexivity regarding learning experiences and achievement of the outcomes of the curricula is required on the part of students and teachers.

Although the innovations developed during the course were not technological, the biomedical engineering students in the course benefited by learning about the health context and became familiar with design thinking as an approach to understanding and addressing user needs. The skills acquired would be useful in needs assessment for, and development of, the technological solutions that are more typically designed by biomedical engineers.

References

- Amieva, H.E.A. 2015. Self-reported hearing loss, hearing aids, and cognitive decline in elderly adults: a 25-year study. *American Geriatrics Society*. 63(10):2099–2104.
- Brown, T. 2008. Design thinking. *Harvard Business Review*. 86(6):84–95.
- Chopra, M., Lawn, J.E., Sanders, D., Barron, P., Abdool Karim, S.S., Bradshaw, D., Jewkes, R., Abdool Karim, Q. et al., 2009. Achieving the health Millennium Development Goals for South Africa: challenges and priorities. *Lancet*. 374(9694):1023–1031. DOI: [https://doi.org/10.1016/S0140-6736\(09\)61122-3](https://doi.org/10.1016/S0140-6736(09)61122-3).
- Gardner, D. 2009. Health care reform: through the lens of change. *Nursing Economics* 27(6):419–421.
- Goldman, S., Kaybayadondo Z., Royalty, A., Carroll M.P. & Roth B. 2014. Student teams in search of design thinking. In *Design thinking research, understanding innovation*. H. Plattner, Ed. Switzerland: Springer International.
- Ideo. 2017. Available: <https://w.com/> [2019, May 29].
- Kolko, J. 2015. Design thinking comes of age: the approach, once used primarily in product design, is now infusing corporate culture. *Harvard Business Review*. 93(9).
- Komninou, A. 2019. Customer Journey Maps – Walking a mile in your customer’s shoes. Interaction Design Foundation. <https://www.interaction-design.org/literature/article/customer-journey-maps-walking-a-mile-in-your-customer-s-shoes> [2019, May 30].
- Lehoux, P., Daudelin, G., Demers-Payette, O. & Boivin, A. 2009. Fostering deliberations about health innovation: what do we want to know from publics? *Social Science in Medicine*. 68(11):2002–2009. DOI: 10.1016/j.socscimed.2009.03.017
- Levitt, N.S., Steyn, K., Dave, J. & Bradshaw, D. 2011. Chronic noncommunicable diseases and HIV-AIDS on a collision course: relevance for health care delivery, particularly in low-resource settings – insights from South Africa. *American Journal of Clinical Nutrition*. 94(6):1690s–1696s. DOI:10.3945/ajcn.111.019075.
- Mayosi, B.M., Flisher, A.J., Lalloo, U.G., Sitas, F., Tollman, S.M. & Bradshaw, D. 2009. The burden of non-communicable diseases in South Africa. *Lancet*. 374(9693):934–947. DOI:10.1016/S0140-6736(09)61087-4.
- Philips. 2014. Experience Flows. Understanding people and their experiences to deliver meaningful innovations. <https://www.philips.com/consumerfiles/newscenter/main/design/resources/pdf/Inside-Innovation-Backgrounder-Experience-Flows.pdf>
- Philips. 2016. Philips Cocreate Toolkit. Philips, The Netherlands.
- Renard, H. 2014. Cultivating design thinking in students through material inquiry. *International Journal of Teaching and Learning in Higher Education*. 26(3):414–424.
- Ritchie, J. & Lewis, J. 2003. *Qualitative Research Practice. A Guide for Social Science Students and Researchers*. London: SAGE Publications.

- Santos, A.E.A. 2014. Design thinking applied to the health sector: a case study in a Brazilian hospital product. *Management and Development*. 12(2):89–99.
- Schweitzer, J.E.A. 2015. The design thinking mindset: an assessment of what we know and what we see in practice. *Paper presented at the Design for Business: Research Conference Melbourne Australia*.
- Stanford University. Hasso Plattner Institute of Design. 2017. Available: <https://dschool.stanford.edu> [2019, May 29].
- Tideholm, A. & Rydén, O. 2015. *Design thinking as facilitator for innovation in Swedish healthcare: a case study at Karolinska University Hospital*. M.Sc. thesis. Chalmers University of Technology Goteborg, Sverige. Available: <http://publications.lib.chalmers.se/records/fulltext/222954/222954.pdf> [2019, May 29].
- Wallhagen, M. 2009. The stigma of hearing loss. *Gerontologist*. 50(1):66–75. DOI: <https://doi.org/10.1093/geront/gnp107>.

Chapter 11

Implementing a Design Methodology: Concept for a Head Positioning Device for Hospital Beds

O.P. Popoola, O.J. Balogun, N. Irurhe, O. Adesogan,
K.K. Adewole, S.K. Fasogbon, E. Wessels, G. Beukes & S. Sivarasu

Introduction

This chapter reports on the learning experience in a six-week Medical Device Design course in the Division of Biomedical Engineering at the University of Cape Town (UCT). The six participants were academics from the University of Lagos and the University of Ibadan in Nigeria, comprising five engineers (civil, mechanical, industrial and systems engineering) and a radiologist. The course facilitators consisted of two junior and one senior faculty members from UCT. The design process was guided by that of Zenios et al. (2015).

The general steps followed in the design process are needs finding and needs screening, concept generation, concept selection, and prototyping. This chapter describes the convergence towards initially two and then one concept which met a medical need, was technically feasible within the available time, and had a reasonable likelihood of commercial viability. A head positioning device for hospital beds was selected as the focus of the course

Needs finding

“How do you identify an important unmet medical need where there is good clinical, scientific, and market knowledge to suggest that a solution to the need will be feasible and will have a reasonable likelihood of commercial viability?” (Zenios et al., 2015)

The participants had an interest in identifying needs that were relevant for Nigeria. Table 1 gives some general facts about this country and its health system.

Table 1. General facts about Nigeria	
Classification	<ul style="list-style-type: none"> • Lower-middle-income country
Administrative Structure	<ul style="list-style-type: none"> • 36 federal states • 774 Local government areas • One federal capital (Abuja)
Population & GDP	<ul style="list-style-type: none"> • 186 million people and gross GDP of 405.1 billion USD. (World Bank, 2016)
Health facilities	<ul style="list-style-type: none"> • Over 34,000 health facilities
Ownership of health facilities	<ul style="list-style-type: none"> • 23,028 (67%) government owned, 11,395 (33%) private (Makinde et al., 2014)
Distribution of health facilities	<ul style="list-style-type: none"> • 30,345 (88%) primary • 3,993 (11.6%) secondary • 85 (0.25%) tertiary (Makinde et al., 2014)

Inventory of skills

Not only the interests, but also the available skills, of the participants were assessed with a view to ensuring that the course project would be matched to the capabilities of the team. In the first session, the course instructors helped the team through the process of formulating a personal inventory – skillsets that each one brings to the table. This helped everyone become familiar with available skillsets and experience.

Observation and problem identification

The team visited a tertiary health facility in Cape Town - Groote Schuur Hospital - to interact with clinicians, caregivers and patients on order to establish what the users needed. One insight gained from a nurse was the occupational hazard associated with the set-up of manually operated hospital beds. She always had body pain after work whenever she had to set up the beds because over time, the beds had become stiff and required considerable effort to adjust to required settings.

Needs statements

Back in the classroom, the team had to learn how to translate a problem into a clinical needs statement that is accurate, broad in scope and not tied to specific solutions. This was initially difficult for engineers whose minds have been wired to think of solutions to problems. The team however learned to identify the user's needs and not a specific solution. Some similarities were observed between the medical needs in South-Africa and that of Nigeria that helped in developing broad needs statements as shown in Table 2.

Needs screening

“After the winnowing of many needs, a rigorous follow-on process of screening and specification is required before you begin inventing” (Zenios et al., 2015)

Disease state fundamentals

Disease research was done for the scope of patients covered by the needs statements to provide a foundation for understanding the underlying disease state. Such research insight helps in the appraisal of available treatment options, market size and type, as well as the key stakeholders. It helps in clearly defining the clinical, technical, and commercial feasibility of the project. Information was obtained from medical textbooks, peer-reviewed articles on clinical presentation and clinical outcomes, and economic data relating to the relevant health conditions. The radiographer “breathe assist” lights and the head positioning device did not require research in disease fundamentals as their use would be generic and not particular to any kind of disease. These needs were prioritised.

Table 2. Needs statements

	Project title	Needs statement
1	Development of battery-powered infant operating table	Surgical team needs a way to maintain an optimal operating room temperature that is comfortable for the team and prevents infant hypothermia in areas without reliable power supply.
2	Development of enteral feeding device	Nurses and caregivers need an easier, affordable and more efficient way to feed patients with eating difficulties because hospital wards are short-staffed.
3	Development of real-time blood pressure monitoring device	Health professionals (and individuals) need a way to measure blood pressure accurately and reliably because of the morbidity and mortality rates associated with high blood pressure.
4	Development of radiographer “breathe assist” device	Radiographers need a way to fix the patient in the standard radiographic position and reduce breathing artifacts during X-ray examination for good quality images at first exposure, reducing unnecessary repeat scans and errors in reporting.
5	Development of head positioning device	Hospitals need a way to position patients in a required posture on standard (non-adjustable) beds because of a shortage of inclinable (adjustable) beds.
6	Development of a bubble continuous positive airway pressure device	Health Professionals need a way to help patients with respiratory distress syndrome to overcome breathing difficulties with a view to reducing morbidity and mortality because existing technologies are expensive and inefficient.

Stakeholder analysis

A careful identification of stakeholders is an important step in the biodesign process. Stakeholders affect the innovation directly or indirectly. They can determine to what extent the solution to an identified need is implemented or even accepted.

In trying to identify the stakeholders, the group first had to determine who is the “user”. In some instances, this wasn’t very obvious. For example, it initially appeared patients were the users of the head positioning device. However, after a more careful deliberation, it was concluded that the actual users were the nurses and caregivers. These caregivers could decide to use the device to manage patients or reject it.

Another lesson learned about stakeholder analysis is the importance of ensuring that no stakeholder is left out. Since their decisions, actions or inactions will affect the success of the product, failure may result if critical stakeholders are omitted. But then how do we define the key stakeholders? The concepts of Business to Business (B2B) and Business to Customer (B2C) sales models assisted in the identification of the stakeholders. In the B2B model, products or services are sold to other businesses. In B2C on the other hand, products are sold directly to consumers. For the head positioning device and the radiographer “breathe assist” device, the main stakeholders identified are shown in Table 3.

Table 3. Stakeholders for two projects that were prioritised

	Need	Stakeholders
1	Radiographer breathe assist device	<ul style="list-style-type: none"> • Hospitals • Radio-diagnostic centres • Radiographers • Radiologists • Patients • Equipment manufacturers • Medical insurance companies • Health Professional bodies • Regulatory authority • Policymakers
2	Head positioning device	<ul style="list-style-type: none"> • Hospitals • Government • Nurses • Caregivers • Patients • Patients' relatives • Medical insurance companies

Market analysis

In order to design an innovative product, market analysis at the initial stage of biodesign innovation is very important. Market analysis is a holistic assessment of market size, market dynamics and competition for a new product. The population of people (patients) and the number of hospitals, health workers, manufacturers, private organizations and government agencies that would use the product provided a basis for estimates. The national health budgets (for previous years and the current year, and future estimates), government policies and procurement processes in the health sector, and import and export statistics from national chambers of commerce, were used to determine the market dynamics for the product. To assess the market competition, the pros and cons of the existing solutions in the context of affordability, technology, ease of use, maintenance, durability and stakeholder requirements, were reviewed.

Some of the key findings for the head positioning device were that the ratio of hospital beds to the population size is inadequate in Nigeria, despite recent growth (US. Commercial Service, 2016), and that existing solutions are pricey, not portable, or have a fixed angle. For the radiographer “breathe assist” device, no suitable solution was available, despite the large number of routine and diagnostic chest X-ray examinations taking place in Nigeria annually.

Needs filtering

Filtering needs poses a challenge especially when multiple needs criteria appear equally important. A consensus scoring process was used to determine the most important need components. While needs filtering was somewhat subjective, it allowed for consensus critique of the different ideas. The needs filtering stage helped the team outline the criteria that any design solution should satisfy for that need. This information was then used as the starting point for the generation of preliminary solution concepts. The head positioning device was selected as the focus of a conceptual design. Table 4 shows the application of needs filtering for the head positioning device.

Table 4. Needs filtering template for head positioning device							
	Head Positioning Device						
	Weighting (1-3)						
	Market size	Patient impact	Provider Impact	Design Feasibility	Effect on patient's condition		
	1	2	3	2	3		
Need	Rating (Score 1= low to 5=high)					Total score	Rank
Affordability	2	3	5	4	1	34	6
Durability	3	4	5	2	4	42	2
Sterilization	4	5	5	1	4	43	1
Maintenance	1	1	4	3	3	30	8
Portability	5	2	5	3	1	33	7
Ease of use	4	3	4	2	3	35	5
Ergonomics	3	4	4	2	4	39	3
Adjustability	3	4	5	3	2	38	4
Non-dependence on electricity	3	2	2	3	1	22	10
Low requirement for technical expertise	2	3	4	3	1	29	9

Head positioning device

Hospital beds can be equipped with devices that allow a range of postures for patients. The WHO (2000) defines a hospital bed as one that is regularly maintained for the accommodation and full-time care of a succession of inpatients and is situated in wards or a part of the hospital where continuous medical care for inpatients is provided. The number of hospital beds determines the capacity for health care delivery to inpatients in hospitals (Pantzartzis, Edum-Fotwe & Price, 2017).

Standard hospital beds cannot be adjusted for angular positioning of the body. Manual hospital beds are adjustable and use a hand crank mechanism for Fowler's angulation, i.e. when the head of

the bed is elevated (Fowler, 1900). Semi-electric hospital beds make use of both an electric motor and manual control to give angle adjustment, to the head and foot sections, and the height of the bed respectively. Fully electric hospital beds feature electric motor controls that raise the head, foot and height of the bed frame with a push of a button (Green, 2002; McKee & WHO, 2004; Catalano & Coolidge, 2006).

Three patients have been estimated to die daily in Nigeria due to a shortage of hospital beds (Akuki, 2017). The majority of hospital beds in Nigeria are basic non-adjustable beds. Lagos University Teaching Hospital has 761 beds with only five ICU beds while University College Ibadan has 850 beds with 12 adjustable beds (Shobowale et al., 2015; Somotun et al., 2017). The “no bed space syndrome” in the emergency section of Nigerian hospitals can be attributed not only to insufficient infrastructure, but also to the limited number of adjustable beds for patients who must be managed in specific positions. Poor national health budget, added to the high cost of adjustable medical beds, as well as space limitations, make acquisition of adjustable beds difficult in a low-resource economy. It therefore appears reasonable to develop ways by which non-adjustable medical beds in the hospitals can function like adjustable medical beds.

The design goal was a mechanically operated medical device that would be portable, adjustable and affordable, and could be mounted on a standard hospital bed to give angulation to body posture. It would be manually operated for use in rural areas and where there is unstable power supply. This would enable healthcare providers to manage critically ill patients who have respiratory challenges or need to be positioned at different angles during the course of treatment for other reasons. The device would be safe, easy to operate and portable.

Concept generation and selection

Concept generation was meant to produce design ideas; it begins with ideation and brainstorming. It is interesting to reflect on how difficult it was to defer judgment and critical thoughts until later. Ideas were quickly shot down based on “how good” or “not good” they were. Sometimes discussions wandered off in different directions, but they eventually came back on course. This affected the productivity and flow of the discussions. But as soon as team members began leveraging each other’s ideas to make new suggestions, the ideation process began to take shape. Team members had to learn to listen more than talk during this process.

The concepts were scored and ranked based on the design requirements of the device, to inform the final component of the biodesign process before prototyping, namely concept selection.

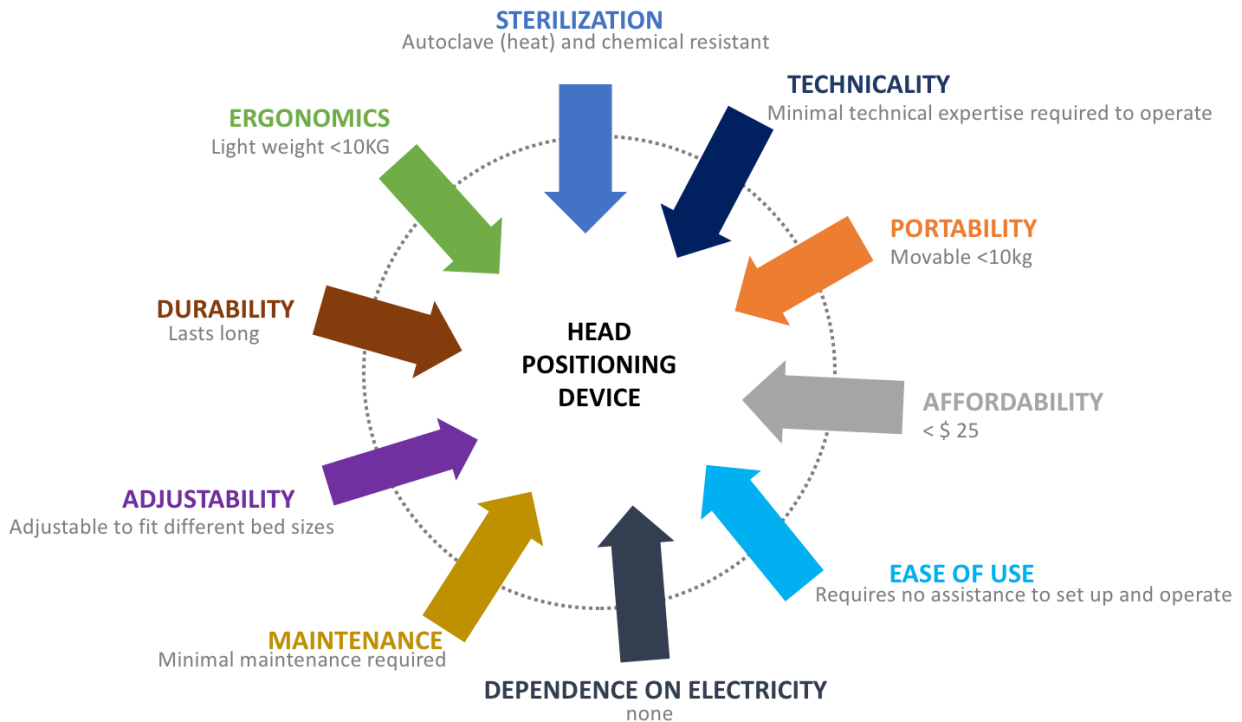

Figure 1: Needs specification for the head positioning device.

During the ideation process, different designs of the head positioning device were considered. Different crank-shaft, lever and screw mechanisms with rotary, oscillating, linear and reciprocating components were considered. The designs were manual, semi-automated or fully automated. Material types considered included steel, aluminium, plastic, wood, alloys, and composite.

Each design idea was carefully assessed based on the outcome of the needs screening and filtering. The design concept that was selected, most satisfied the design specifications.

Other requirements

Additional information was sought related to reimbursement, regulatory requirements, and business models in the Nigerian market space.

Reimbursement

Some leading questions the team tried to answer were:

- Will the existing health care payment infrastructure in Nigeria be able to accommodate a solution to the need for a head positioning device for use on basic hospital beds if such a solution becomes available?
- Who pays (or reimburses) for this device? Will the target market segment be large enough to make the production of this device financially viable?

To answer these questions, further research was done about the healthcare payment infrastructure in Nigeria. The key findings were:

- Over 90% of Nigerian people still pay for health care out-of-pocket (Adewole et al., 2015) and the National Health Insurance Scheme (NHIS) serves less than 10% of the population (Adewole & Osungbade, 2016).
- There is a shortage of hospital beds in Nigeria (US. Commercial Service, 2016).
- Normal hospital beds cost \$100 – \$150 while adjustable hospital beds cost \$250 – \$300.
- No existing portable device is available for adjusting the patient’s head on regular hospital beds.

Given the statistics, a compelling value proposition exists for hospital management and clinicians to adopt the proposed device. This head positioning device would serve the purpose of making regular beds useable as inclinable hospital beds for managing patients in various Fowler positions. A compact, portable, strong, lightweight and ergonomic design would make it easy for caregivers to set up and stack away when not in use. Components that are both heat and chemical resistant would make the device easy to clean and to maintain high clinical hygiene standards. The device should be affordable for primary, secondary or tertiary hospitals in a low-income economy.

Regulatory

Obtaining regulatory authorization is the first major hurdle that manufacturers of medical devices must overcome to be successful at the commercialisation stage of products (Theisz, 2015). In Nigeria, the National Agency for Food and Drug Administration and Control (NAFDAC) has guidelines for registration of medical devices. The guideline stipulates that “...no medical device shall be manufactured, imported, exported, advertised, sold or distributed in Nigeria unless it has been registered in accordance with the provisions of ACT CAP F33 (LFN) 2004 (formerly decree 19 of 1993) and the accompanying Guidelines” (NAFDAC, 2018). In this research, it was found that products with US Food & Drug Administration (FDA) approval or CE marking will be approved by regulators if the stipulated guidelines are followed.

The closest device approved by the US FDA is a manually adjustable hospital bed. According to the FDA, it is “a device intended for medical purposes that consists of a bed with a manual mechanism operated by an attendant to adjust the height and surface contour of the bed. The device includes movable and latchable side rails.” (US. FDA, 2017). Both the FDA and CE classification classifies this device as Class I as shown in the side-by-side comparison of Table 5.

Table 5. Manual adjustable hospital bed – FDA and CE classifications (US.FDA, 2017)

	FDA	CE
Common name	Manual adjustable hospital bed	Manual adjustable hospital bed
Product type:	Medical device	Medical device
Classification panel	General hospital	-
Device class	Class I	Class I
	<i>Reason(s)</i> Minimal potential harm to patients -typically, simple in design -adequate experience where predicate device exists	<i>Reason(s)</i> Relatively low-risk devices that do not enter the human body
	<i>Class I sub classification</i> (a) Exempt device	<i>Class I sub classification</i> (a) general low-risk device
	<i>Requirements for exempt device</i> Exempted from premarket clearance. Clinical trials not required. Proof of safety and/or efficacy not required. Must meet the following “general controls”: • Establishment registration with FDA. • Medical device listing. • General FDA labeling requirements. • Compliance with quality system regulation	<i>Requirements for general low-risk device</i> Certification by the manufacturer. Does not require notified body certification.
Regulatory branch	General hospital devices branch	Not applicable Certification by the manufacturer
Regulation number	21 CFR 880.5120 (US.FDA, 2017)	-
Class number		
Submission type	510(k) exempts	Certification by the manufacturer
Physician review panel	Division of Anesthesiology, General Hospital, Infection Control and Dental Devices, Office of Device Evaluation (ODE), Center for Devices, Health (CDRH) of the FDA	-
Product code:	FNJ	N/A

Business model

A business model is a systematic approach that illustrates how a product will generate revenue and deliver value to customers. It provides a clear view of the revenues, costs, profits, financing, intended customer base and the business enterprise delivering the value (Teece, 2010; Zenios et al., 2015). There are nine common types of medical technology business models in the medical device industry, namely: disposable, reusable, capital equipment, service, fee-per-use, over the counter, prescription, and physician-sell. The head positioning device falls into the reusable category. The product is intended to have repetitive use before wearing out, a moderate life-span and low cost. Table 6 is a business model canvas that summarizes the building blocks such as customers, route to market, value proposition and finance.

Table 6. Business model canvas for head positioning device

Key partners	Key activities	Value proposition	Customer relationships	Customer segments	
Ministry of Health. Hospital management. Healthcare professionals. Medical device outlets and stores. Hospital bed manufacturers. Distributors. Advertising agencies. Marketing services.	Production Maintenance Servicing	Conversion of plain hospital bed into inclinable hospital bed. Portability. Convenience/Usability. Ease of maintenance and sterilization. Cost reduction. Reduction in occupational hazard. Reliability and risk reduction. No need for electricity.	After sales service. Training on the use and maintenance of the product.	Government hospitals. Private hospitals. Health clinics. Variations: Business-to-Business, Business-to-Government. Decision-Makers: buyers	
	Key Resources		Channel Stores		
	Patents Brand Production facilities		Phone / mail/ website Retailers Distributors		
Cost structure	Production Distribution Marketing Branding	Maintenance Variable costs	Revenue Streams	Asset sales	Maintenance Fee

Conclusions

The chapter has described the design methodology followed in a medical device design course, with the concept for a head positioning device as an illustrative example. Further work would require the design of the device and selection of suitable materials, prototyping, and testing in a laboratory and a clinical setting.

Prospects for the head positioning device

The head positioning device would be new to the market. It was conceived as a solution to the acute shortage of medical beds suitable for managing patients who require angular positioning during treatment or recovery. The most common regular hospital beds are flat and patients are often managed at angular positions using pillows; this leads to patient discomfort and physical strain on caregivers. Medical beds that are semi- or fully automated are available to adjust patient positions; however, in low-resource economies, they are considered pricey and, in most cases, have to be imported. Thus, the proposed portable device can be used to enhance regular hospital beds for use in managing patients who require specified angular positions.

Insights on team design

Team members learned the importance of managing communication and interpersonal dynamics in the team effort. In a shared leadership setting where members have divergent opinions on how things should be done, it becomes critical for both the mentors and team members to be able to carefully navigate potential conflict areas. Openness to constructive criticism and the contributions of others makes it easy for better ideas to emerge from team brainstorming and interaction.

Acknowledgments

Research reported in this publication was supported by the Fogarty International Center of the National Institutes of Health under award number D43TW009374. The design team wishes to express profound appreciation to the Principal Investigator and Co-Investigators of this grant.

References

- Adewole, D.A., Adebayo, A.M., Udeh, E.I., Shaahu, V.N. & Dairo, M.D. 2015. Payment for health care and perception of the National Health Insurance Scheme in a rural area in Southwest Nigeria. *American Journal of Tropical Medicine and Hygiene*. 93(3):648-654. DOI:10.4269/ajtmh.14-0245.
- Adewole, D.O. & Osungbade, K.O. 2016. Nigeria National Health Insurance Scheme: a highly subsidized health care program for a privileged few. *International Journal of Tropical Disease & Health*. 19(3):1-11.
- Akuki, A. 2017. *Three die daily for bed shortage in govt hospitals*. Available: <https://independent.ng/abuja-three-die-daily-for-bed-shortage-in-govt-hospitals/> [2019, May 06].
- Catalano, B., & Coolidge, T. 2006. *Evaluation and design of a hospital bed to be manufactured and used in China*. Available: <https://digitalcommons.wpi.edu/mqp-all/2262> [2019, May 06].
- Green, L.V. 2002. How many hospital beds? *INQUIRY: The Journal of Health Care Organization, Provision, and Financing*. 39(4):400-412.
- Fowler, G.R. 1900. Diffuse septic peritonitis, with special reference to a new method of treatment, namely, the elevated head and trunk posture, to facilitate drainage into the pelvis, with a report of nine consecutive cases of recovery. *Medical Records*. 57:617-623.
- Makinde, O.A., Azeez, A., Bamidele, S., Oyemakinde, A., Oyediran, K.A., Adebayo, W., Fapohunda, B., Mullen, S., et al. 2014. Development of a master health facility list in Nigeria. *Online Journal of Public Health Informatics*. 6(2):184. DOI:10.5210/ojphi.v6i2.5287.
- McKee, M. & WHO. 2004. *Reducing hospital beds: what are the lessons to be learned*. (No. EUR/04/5046933). Copenhagen: WHO Regional Office for Europe.
- NAFDAC. 2018. *Guidelines for registration of imported medical devices in Nigeria*. Available: https://www.nafdac.gov.ng/wp-content/uploads/Files/Resources/Guidelines/R_and_R_Guidelines/IIMPORTS/Guidelines-for-the-Registration-of-Imported-Medical-Devices.pdf. [2019, May 06].
- Pantartzis, E., Edum-Fotwe, F.T. & Price, A.D. 2017. Sustainable healthcare facilities: reconciling bed capacity and local needs. *International Journal of Sustainable Built Environment*. 6(1):54-68.

- Shobowale, E., Ogunsola, F., Oduyebo, O. & Ezeaka, V. 2015. A study on the outcome of neonates with sepsis at the Lagos University Teaching Hospital. *International Journal of Medicine and Biomedical Research*. 4(1):41-49.
- Somotun, O.A.A., Osungbade, K. O., Akinyemi, O. O., Obembe, T. A. & Adeniji, F.I. 2017. What factors influence the average length of stay among stroke patients in a Nigerian tertiary hospital? *The Pan African Medical Journal*. 26:228. DOI:10.11604/pamj.2017.26.228.12249.
- Teece, D.J. 2010. Business models, business strategy and innovation. *Long Range Planning*. 43(2-3):172-194.
- Theisz, V. 2015. *Medical device regulatory practices: an international perspective*. Boca Raton, FL: Pan Stanford.
- US. Commercial Service. 2016. *Healthcare resource guide: Nigeria*. Available: https://2016.export.gov/industry/health/healthcareresourceguide/eg_main_092285.asp [2019, May 06].
- US. FDA. 2017. 21 CFR 880.5120 *Manual adjustable hospital bed*. Available: <https://www.accessdata.fda.gov/scripts/cdrh/cfdocs/cfcfr/CFRSearch.cfm?fr=880.5120> [2019, May 06].
- WHO. 2000. *Hospital beds (per 1,000 people)*. Geneva: World Health Organization. Available: <https://www.indexmundi.com/facts/indicators/SH.MED.BEDS.ZS> [2019, May 06].
- World Bank. 2016. *World Bank Data, World Development Indicators (WDI)*. Available: <http://data.worldbank.org/country/nigeria> [2019, May 06].
- Zenios, S., Makower, J., Yock, P., Brinton, T.J., Kumar, U.N., Denend, L. & Krummel, T.M. 2015. *Biodesign: the process of innovating medical technologies*. 2nd ed. Cambridge: Cambridge University Press.

Chapter 12

Medical Device Concept for Burn Wound Exudate Detection

K. Burke, A. Dai, J. Hauck, M. Glucksberg & A.I. Michael

Background

Wound infection is dreaded in plastic surgery as this ultimately increases patient morbidity and sometimes mortality, particularly for burn wounds. The state of the wound dressing is a day-to-day concern in burn wards. A clean and dry wound dressing is desirable while dirty soaked wound dressings portend infections. Efforts at preventing dressings from reaching the soaked stage have the potential to reduce wound infections.

This chapter illustrates the design of a device to detect imminent strikethrough of wound exudate to alert nursing staff that wound dressings need changing, in response to a need identified at University College Hospital, University of Ibadan. A conceptual design is presented.

The impact of burn wound infection

Burns are a major public health concern. They are recognized by the World Health Organization as the fourth most common type of trauma globally with devastating and sometimes life-long consequences (WHO, 2017).

Infection is one of the leading causes of death of burn patients worldwide (Williams et al., 2009; Ramakrishnan, Bai & Babu, 2016). Burn patients are susceptible to infection due to the loss of the protective skin barrier and immune system impairment (Barlow, 1994; Weber & McManus, 2004). This is directly related to the severity of the burn. Burn wound infection, to which every burn patient is prone if wounds are not adequately and aggressively managed, has a significant impact on morbidity, cost of care and mortality (ISBI. Practice Guidelines Committee, Steering Subcommittee & Advisory Subcommittee [ISBI], 2016). Treatment of infection can be challenging due not only to the cost of antimicrobials but also due to the frequent occurrence of multidrug resistant biofilms on burn wounds (Ramakrishnan et al., 2016). Ogundipe, Adigun and Solagberu (2009) have reported that the highest expense incurred by patients is on the procurement of antimicrobials. The prevention of burn wound infection is integral to favourable outcomes in burn patients (Barlow, 1994; ISBI, 2016; Ramakrishnan et al., 2016).

Approximately 90% of burns occur in low- and middle-income countries. More than a million people per year are affected in low-income countries with 238,000 deaths per year (Peden, McGee & Krug, 2002). This is of great concern as the management of burns is cost and capital intensive. In resource-rich and established healthcare systems the high cost of burn care is borne by the

system while in low-income countries with poor healthcare systems it is borne largely by the patient and the patient's family (ISBI, 2016). Achieving the required standard of care therefore is challenging in low-resource countries.

The significance of wound exudate strikethrough

One major characteristic of the burn wound is its propensity to be heavily exudative. The visible presence of the exudate on the surface of the saturated dressing is called strikethrough (World Union of Wound Healing Societies [WUWHS], 2007), as shown in Figure 1.



Figure 1: Wound exudate strikethrough on burn wound dressing.

This exudate is a protein-rich fluid that leaks from the wound. It contains electrolytes, inflammatory mediators, enzymes and inflammatory cells (WUWHS, 2007). When exudate leaks out, it not only creates an unsanitary environment but also, due to its protein content, is a nutrient rich medium for colonization and proliferation of microorganisms that can lead to burn wound infection (Weber & McManus, 2004; WUWHS, 2007; ISBI, 2016). Therefore, the burn dressing must incorporate a highly absorptive component that prevents leakage of the exudate onto the dressing surface and the bedding. Wound dressing agents that have the ability to absorb large amounts of exudate while still maintaining a moist environment necessary for healing are ideal; examples include hydrocolloids, alginates, and carboxymethyl cellulose dressings (WUWHS, 2007). However, these dressings are expensive and not practical for use in resource-poor countries. Gamgee is a low-cost surgical dressing invented by Sampson Gamgee in 1880 (Barlow, 1994). It comprises a thick layer of cotton wool wrapped in a thin layer of gauze. This is readily available in low-income countries as it can be bought, or custom made as is done in Nigeria (Olawoye, Osinupebi & Ayoade, 2013).

Current practice of burn wound care at the University College Hospital

The burn unit at University College Hospital, University of Ibadan, is a 12-bed ward that sees approximately 87 acutely burned patients per year (Adejumo & Akese, 2012). Gamgee is used as the absorbent dressing for all burn patients. Burn wounds are cleaned with normal saline and the 4-layer dressing applied (Adejumo & Akese, 2012; Olawoye et al., 2013). The first layer, directly on the wound, is antiseptic impregnated paraffin gauze that serves as a non-adherent layer. The next layer is made up of a thin layer of gauze that acts as a wick, transmitting the wound exudate to the third absorbent layer, which is Gamgee. The fourth layer is crepe bandage, which serves to keep the dressing in place. The signal for a change of dressing is usually the occurrence of strikethrough and this can be seen from 12 to 48 hours after dressing application depending on the rate of wound exudation.

The ideal environment for burn care is to have one burn patient per cubicle. The single open ward system that prevails in low-income countries, increases the risk for cross-infection (Weber & McManus, 2004; ISBI. Practice Guidelines Committee, 2016). Additionally, strikethrough may go undetected and unchanged for hours due to a low nurse to patient ratio and the unavailability of dressing materials. This increases the potential for a wound infection, an example of which is shown in Figure 2.



Figure 2: Wound infection

Concept for a medical device

Weak collaborations between the Department of Plastic Reconstructive and Aesthetic Surgery of the University College Hospital and the Faculty of Technology of the University of Ibadan led to an invitation to attend a workshop on Biomedical Engineering under a National Institutes of

Health, Fogarty International Center, grant at Lagos, Nigeria, in September 2015. At this workshop, the idea of developing a wound care device to detect imminent strikethrough was developed. Discussions with the Chair of the Department of Biomedical Engineering, Northwestern University (NU), on this need, and subsequent involvement of students from a senior-level biomedical engineering capstone design course sequence at NU, resulted in the development of the design concept for the device.

User needs

The design requirements for the device, based on the five needs of medical staff from the burn ward at University College Hospital, Ibadan, are outlined below.

Reliability: The device reliably alerts staff that strikethrough is imminent. False alerts would lead to unnecessary dressing changes and increased cost to patients and workload for staff.

Minimal interruption of workflow: The device will deliver alerts noticeably but without interruption to the usual workflow in the burn ward. An audible alert would disturb other patients and the staff, while unconscious or sleeping patients may not pick up somatosensory alerts (e.g., vibrations). Application of the device, and subsequent interactions with the device, should not lead to significant increases in time spent with the patient.

Longevity: The erratic power supply experienced at University College Hospital dictates that the device should be able to operate independently of the main power supply.

Affordability: The device should be cost effective. The marginal increase in cost for the hospital should be considerably lower than that of having to manage an infected wound.

Sanitisability: The device should be sanitisable so it can be reused. Methylated spirit and povidone iodine are common agents used for sanitisation and should be able to be safely applied to the device. Alternatively, if the device is not sanitisable, its cost will be low enough to justify single use.

Based on the above needs, requirements and specifications for the device were identified as illustrated in Table 1.

Table 1. User needs, requirements and specifications for the medical device.			
User need	Design requirement	Metric	Value
Reliability	Ability to detect imminent strikethrough	Number of remaining layers of Gamgee prior to strikethrough	1–2 layers
	Acceptable detection rate	Detection rate	50% of all true positives
Minimal disruption to workflow	Fast alert	Time it takes the nurse to detect need for dressing change	30 seconds
	Fast application	Additional time required to apply the dressing	5–10 minutes
Longevity	Able to withstand erratic power supply	Time the system is able to run without an external power source	10 days
Affordability	Cheaper than managing an infected wound	Average cost of device	\$50 per unit
Sanitisability	Available materials should be used for sanitisation	Components can be sanitised by alcohol or iodine solution	yes/no

Design concept

The design concept comprises three levels of electronic components:

- Detection modules
- A supermodule
- A nurse's station module (NSM)

The modules are placed on the dressing but under the crepe bandage to detect exudate in the Gamgee. The modules emit infrared (IR) light which is reflected off the exudate. When they detect a certain level of exudate in the bandage they send an alert to the supermodule by emitting IR light to the supermodule. There are 11 modules per supermodule. The supermodule in turn sends an alert to the NSM via a Bluetooth signal, informing the nurses that the dressing should be changed. The detection of the exudate is illustrated in Figure 3, while Figure 4 depicts the module configuration and signal propagation.

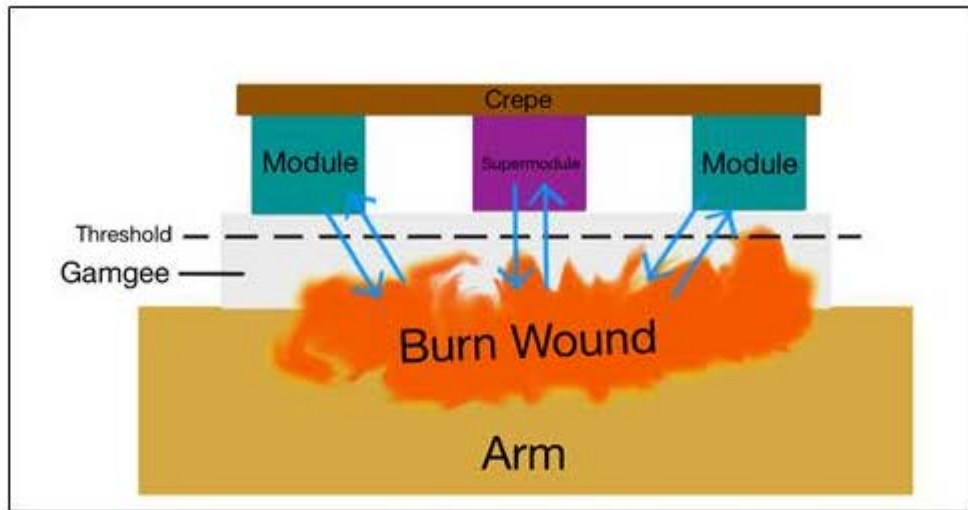

Figure 3: Concept for detection of imminent strikethrough from a burn wound on a patient's arm.

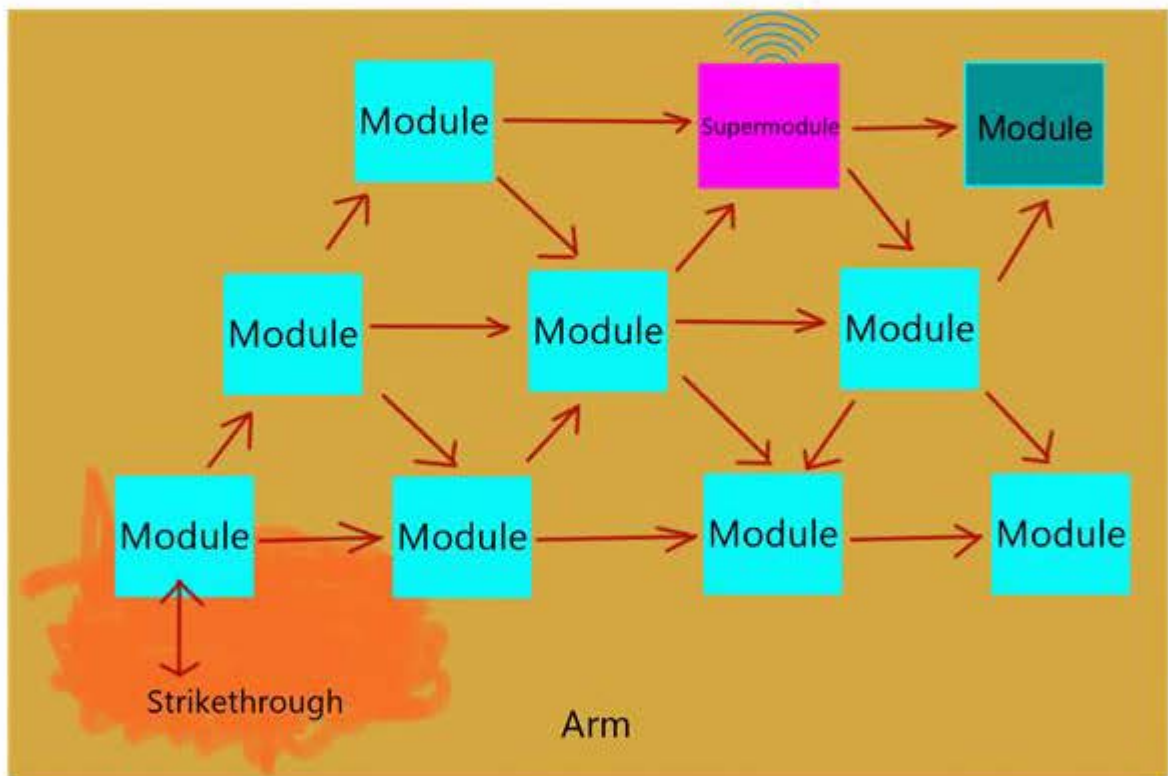

Figure 4: Module configuration and signal propagation for detection of imminent strikethrough.

The primary function of each module is to direct IR light through the dressing, measure the light reflected back, and determine the level of strikethrough that has been reached. To accomplish these tasks, each module consists of a microcontroller, an IR light emitting diode (LED), and an IR phototransistor. The IR LED is responsible for directing IR light through the dressing. The IR phototransistor detects the amount of IR light incident on the module and translates that reading

into a voltage. The module will then determine whether this voltage level indicates approximately 1–2 layers of Gamgee remaining.

Additionally, each module is responsible for transmitting its status to the supermodule, as seen in Figure 4. To enable this, each module will require a built-in personalized identification (ID) signal. The modules will transmit information to the supermodule tagged with their personalized ID. The module placement will be such that neighbouring modules can detect each other's signals. These modules will send signals in four separate situations: (1) when they are first told to initiate function, (2) when they detect that exudate has reached threshold strikethrough level, (3) at regular intervals when they are checking in with the supermodule to confirm they are still functional, or (4) to propagate a signal that has been sent by a neighbouring module. When the modules send a type 1 or 3 signal they will simply transmit their ID number; when they send a type 2 signal they will send an alert signal that is common across all of the modules. In order to provide a mechanism for extended transmission of these signals, all modules will be monitored at prescribed intervals for signals from their neighbouring modules. When a type 1, 2, or 3 signal is detected from a different module, the module will re-transmit that signal. In this way all signals will eventually propagate through redundant pathways to the supermodule, which will address them further. Modules will have enough memory to record the signals they have sent and will send them no more than once per hour to save power.

These modules will remain in a detect-only “sleep mode” the majority of the time, waking up for only a few seconds per hour under normal operating conditions to check for strikethrough and indicate that the modules are still operational. However, this mode will be interrupted whenever a signal from a different module is received in order to propagate this signal as previously explained.

Supermodule

The supermodule is responsible for receiving the data the modules provide, detecting which modules are present, and alerting the user that strikethrough is imminent by sending a signal to the NSM. Each supermodule will contain the detection system described above for the modules, but it will also contain a bluetooth chip capable of communicating with the NSM. Its communication to the NSM will be stamped with a device ID so that the NSM will be able to differentiate between supermodules located on different patients.

When the system is initiated at the beginning of a cycle, the supermodule will be responsible for collecting and storing the individual ID signals transmitted by each of the individual modules. It will furthermore be responsible for checking to make sure all of these modules are transmitting regularly by determining if their ID numbers are still being transmitted. If either a module alert signal is detected or one of the modules' ID numbers is not transmitted, the supermodule will send an alert to the NSM that will signal to the user that the dressing needs attention.

These supermodules will remain in a detect-only “sleep mode” the majority of the time, waking up for only a few seconds every hour under normal operating conditions to check for strikethrough in the same manner the modules do. This mode will be interrupted whenever a signal from a module is received to log the module’s ID number or alert the NSM to a dressing needing attention.

Nurses’s station module

The NSM is responsible for receiving a signal from each of the supermodules in use and communicating to the nurses the status of the dressing associated with each supermodule. Each dressing will have one supermodule with a unique ID recognised by the NSM. The NSM will contain a bluetooth chip that can communicate with each of the supermodules. The NSM will use this bluetooth connection to check if the supermodule is functioning properly at regular intervals and will additionally continuously monitor for an alert signal from any of the supermodules. To do this the NSM will have a processor capable of differentiating between the signals sent from each of the supermodules and will have sufficient memory storage to keep track of the alert history from each supermodule. The NSM will also have an LED screen to communicate the status of each supermodule. This screen will notify the nurse’s station of any problems communicated by the supermodules through a visual alert.

Design considerations for the modular system

Table 2 illustrates the decision-making process that drove the design of the wireless, modular system and the type of data transmission used. Table 3 shows the ranking of the solutions against the user needs, with ease of implementation added. The ability to be sanitised is not considered here as the housing, rather than the components, would be sanitised. Bluetooth was selected for the communication with the NSM and IR for communication between modules.

Table 2. Alternatives matrix detailing advantages and disadvantages of the types of data transmission initially considered.

	Description	Advantages	Disadvantages
Wired	Medical grade electrical wires used for a direct device connection	<ul style="list-style-type: none"> - Limited signal interference - No theoretical maximum range 	<ul style="list-style-type: none"> - Add clutter to patient's space - Limits patient mobility
Infrared	IR light (700nm–1mm) used to transmit data between devices	<ul style="list-style-type: none"> - IR LED and photosensors are extremely cheap - Minimal sources of outside interference - Simple, cost-effective solution for our communication requirements - Capable of preventative signalling 	<ul style="list-style-type: none"> - Effectiveness of signal dependent on line-of-sight / scattering properties of the medium - Data not easily securable - Low information density - Low signalling range
Bluetooth Smart	Low-energy version of standard Bluetooth protocol (2.4–2.485 GHz) used to transmit data between devices (1 MB/s)	<ul style="list-style-type: none"> - High data security - Moderate data transmission rate - Moderate information density- Capable of preventative signalling 	<ul style="list-style-type: none"> - Moderate/Low power consumption - Possible signal interference from commercial devices - Maximum range of 20 m
RFID	RF signal transceivers that operate between 120 kHz (LF) and 433 MHz (UHF); used to transmit data between devices	<p><i>Passive RFID:</i></p> <ul style="list-style-type: none"> - No internal power requirements - Extremely low-cost and low-maintenance <p><i>Active RFID:</i></p> <ul style="list-style-type: none"> - Capable of preventative signalling - Moderate detection range 	<p><i>Passive RFID:</i></p> <ul style="list-style-type: none"> - Not capable of preventative signalling - Data typically not rewritable - Short detection range <p><i>Active RFID:</i></p> <ul style="list-style-type: none"> - Extremely high costs for readers and tags - Relatively high power consumption for provided data transmission rate / information density
Wifi	Wireless communication operating at 2.4 GHz / 5 GHz (IEEE 802.11) used to transmit data between devices	<ul style="list-style-type: none"> - High transmission rate - High information density - High signal range - High data security 	<ul style="list-style-type: none"> - High power consumption - High costs - Possible signal interference from commercial devices

Table 3. The criteria are ranked on a 5-point scale (1 = Poor, 5 = Good) and assigned a weight on a 3-point scale (1 = Low Priority, 3 = High Priority). The totals are calculated using the weight multiplied by the ranking of the criterion.

Weight	Criteria	Wired	Infrared	Bluetooth	RFID	Wifi
3	Reliability	5	2	4	4	4
3	Affordability	5	5	4	1.5	2
2	Ease of implementation	2	4	4	4	3
2	Longevity	2	5	4	4	2
1	Minimal disruption to workflow	5	5	5	5	5
	Total	43	44	45	37.5	33

Future considerations

The nature of the casing for the modules, the attachment method to secure the modules to dressing, and the specific electronic components to be used in the modules, must be considered against the design requirements and specifications. These considerations will be followed by construction and testing of prototype systems.

Conclusion

We have presented the design concept for a device to detect imminent strikethrough of wound exudate to prevent burn wound infection. Our largest user-base will be medical professionals, and while the design arose in response to needs of a specific hospital, the potential user base will be medical staff throughout hospitals and medical centres in developing nations.

Acknowledgement

Research reported in this publication was supported by the Fogarty International Center of the National Institutes of Health under award number D43TW009374.

References

- Adejumo, P.O. & Akese, M.I. 2012. A five-year prevalence study of burn injury in a Nigerian teaching hospital. *World Hospitals and Health Services: The Official Journal of The International Hospital Federation*. 48(1):31–4.
- Barlow, Y. 1994. T lymphocytes and immunosuppression in the burned patient: a review. *Burns*. 20(6):487–90.
- ISBI. Practice Guidelines Committee, Steering Subcommittee & Advisory Subcommittee. 2016. ISBI practice guidelines for burn care. *Burns*. 42(5):953–1021.
- Ogundipe, K.O., Adigun, I.A. & Solagberu, B.A. 2009. Economic burden of drug use in patients with acute burns: experience in a developing country. *Journal of Tropical Medicine*. 31. DOI: 10.1155/2009/734712.
- Olawoye, O.A., Osinupebi, O.O. & Ayoade, B.A. 2013. Open burn wound dressing: a practical option in resource constrained settings. *Annals of Burns and Fire Disasters*. 26(3):154.
- Peden, M.M., McGee, K. & Krug, E., 2002. *Injury: a leading cause of the global burden of disease, 2000*. Available: https://www.who.int/violence_injury_prevention/publications/other_injury/injury/en/ [2019, May 06].
- Ramakrishnan, M., Bai, S.P. & Babu, M. 2016. Study on biofilm formation in burn wound infection in a pediatric hospital in Chennai, India. *Annals of Burns and Fire Disasters*. 29(4):276.
- Weber, J. & McManus, A. 2004. Infection control in burn patients. *Burns*. 30(8):A16–24.
- WHO. 2017. *Burns*. Available: www.who.int/mediacentre/factsheets/fs365/en/ [2019, May 06].
- Williams, F.N., Herndon, D.N., Hawkins, H.K., Lee, J.O., Cox, R.A., Kulp, G.A., Finnerty, C.C., Chinkes, D.L., et al. 2009. The leading causes of death after burn injury in a single pediatric burn center. *Critical Care*. 13(6):R183.
- World Union of Wound Healing Societies. 2007. *Principles of best practice: wound exudate and the role of dressings: a consensus document*. London: Medical Education Partnership.

Chapter 13

Infant Warming Device or Neonatal Surgery in a Low-Resource Setting

A.O. Coker, T. Lawal, C. Achi, D. Akano, A.O. Olorunnisola, L. Cilenti, Y.H. Lee, M. Simkowski, F. Cummins, M. Doerfler, E. Glowik, R. Lu, A. Williams, M. Chua, I. Ikene, S. Das, D. Gatchell, M. Glucksberg & R.L. Murphy

Background

Thermoregulation is the body's capacity to balance heat generation and heat loss to ensure that the body temperature remains in a range that is suitable for human life. This ability is gradually acquired as a human matures into adulthood. Neonates and infants do not have a fully developed internal regulatory mechanism. This poses a challenge for infants undergoing surgery as they require close monitoring and regulation of their temperature under anaesthesia.

Hypothermia is an observable reduction of the body temperature below 36°C (Leduc & Woods, 2013). The importance of thermal regulation for newborns was discovered in the early 1900s when Pierre Budin reported on a striking variation in mortality rates among infants with different body temperatures (Day et al., 1964). When the temperature drops below the 36°C threshold, the muscles in the body generate heat by the shivering mechanism. Unfortunately, infants are unable to shiver and their internal organs cannot produce enough heat.

Newborns lose body heat in four distinct ways:

- **Evaporation:** This is the largest source of heat loss at child birth. It may result from sweating and other forms of heat loss from the skin or breathing. The rate of evaporation largely depends on both the baby's surface area and the prevailing environmental conditions, i.e., vapor pressure and air velocity. During abdominal surgery the rate of heat loss is increased significantly.
- **Conduction:** This heat loss occurs primarily when the newborn is placed without clothing on a surface such as a table, scale, or bed. Conductive heat loss is greatly influenced by the contact surface area and the difference in temperature between the two surfaces in contact.
- **Convection:** This heat loss occurs when a newborn is exposed to cool environments, e.g., near open doors, windows or fans. The resultant heat transfer from the newborn to the ambient air or liquid is influenced by the newborn's surface area, rate of air flow and temperature difference.

- Radiation: This heat loss occurs when the newborn is placed near cooler objects such as walls, tables and cabinets, without necessarily maintaining a contact with such surfaces. The rate of heat loss will depend on the difference in temperature between the newborn and the adjacent surfaces, the newborn's surface area, and the separating distance between the baby and the solid surfaces.

Neonates and infants easily lose temperature by evaporation, conduction, convection, and radiation. An incubation system can help reduce such heat loss. However, not all heat loss can be avoided, especially that from radiation. Even mild hypothermia can cause some complications such as vasoconstriction.

Hypothermia frequently occurs in infants, especially in newborns, during surgery and anesthesia. Exposure of the thin and moist skin of neonates to lower temperature and humidity, infusion of cold fluids and ventilation with dry gases makes neonates susceptible to hypothermia. A combination of these factors, along with the neonate's physiological properties of large surface area to body mass ratio and deficiency in subcutaneous fat, increases the risk of an infant becoming hypothermic during anesthesia (IDPH, 2017). A drop in temperature is typically expected after general anesthesia. However, this temperature fall should be averted in infants for various medical reasons. Mild postoperative hypothermia may impede immune responses to perioperative wound infection. Hence, hypothermia should be detected through close perioperative monitoring of body temperature in infants, and appropriately treated.

Neonatal hypothermia remains an important public health challenge and a major cause of morbidity in sub-Saharan Africa (Al Hammadi, et al., 2005). Low-tech measures to prevent heat loss and provide warmth are employed in many African countries. A standard protocol for hypothermia prevention in neonates and infants involves a circulating water mattress set at 40°C; providing airway humidifiers for breathing; maintaining a room temperature of approximately 22°C; warming intravenous fluids and blood products, if used; and using a forced warm air circulating blanket any time the infant's body temperature falls below 35.5°C (Leduc & Woods 2013).

While the use of low-tech measures such as hot water bottles, warm rooms, Kangaroo care, and hot stones may be lifesaving in low income settings (Onalo, 2014), there is a need to develop a more efficient and effective warming device to cater to the needs of neonates and infants. This chapter presents the development of a simple warming device for neonates, for use during and immediately after surgery, motivated by a need identified in Nigeria.

Existing infant warming devices for low-resource settings

An example of an infant warming device developed in India, is made up of a biocompatible bed on which the infant is placed, an overhead heater, a skin temperature probe, and a combination of

visual and audio alarms (WHO, 2015:65). The control of heat output can be done either manually or automatically for thermoregulation.

Many existing radiant warmers had typically been fabricated with quartz or ceramic materials which not only took up to 13 minutes to heat up, but also tended to break down easily. Since each additional minute of cold stress could result in increased infant morbidity, this device was developed not only to provide uniform heating but also a faster warm-up time of not more than 4 minutes. Furthermore, the relatively low power consumption coupled with the durability of the heating element results in considerable cost savings. Adequate provision was also made for infection control.

This device is said to be able to operate in both rural and urban settings as well as different categories of healthcare facilities. Although it can withstand some fluctuations in voltage and occasional spikes, it generally requires a stable power supply. It has been sold in 115 countries including Albania, Algeria, Brazil, Bulgaria, Cambodia, Chile, Dominican Republic, Egypt, Gabon, India, Indonesia, Iraq, Jordan, Kazakhstan, Kenya, Lebanon, Macedonia, Nigeria, Palestinian Territory, Philippines, Syria, South Africa, and Vietnam.

An example of a less-sophisticated portable baby warmer, with dimensions 440 x 290 x 70 mm and weighing 4.1 kg, was developed in the USA and is being sold at a retail price of USD 250 (WHO, 2015:66). It consists of a sleeping bag, a pouch of phase change material and an electric heater. In operation, the pouch is heated for 30 minutes before being placed in the sleeping bag. The device, which does not require a constant supply of electricity and water, and has no moving parts, is capable of maintaining the WHO recommended a temperature of 37°C for between 4 and 6 hours, after which it has to be reheated. This technology is well-suited for use in remote healthcare facilities with relatively low doctor/nurse to patient ratios, and where continuous access to electricity is lacking. The target users are neonatologists and paediatricians for whom baby warmers are critical in providing neonatal care for low birth weight infants, with initial implementation in India.

Development of a prototype surgical infant warmer

The devices mentioned above are not intended for surgery. The prototype described below was specifically designed for this purpose.

When an infant undergoes abdominal surgery at the University College Hospital (UCH) in Ibadan, Nigeria, where the operating rooms are kept at around 23°C, an external device is necessary to help regulate the infant's core body temperature. The administration of anesthesia and the exposure of the infant's core to the surroundings lead to a decrease in the infant's body temperature. This decrease in body temperature makes the infant susceptible to perioperative hypothermia, which causes increased susceptibility to wound infections which in turn can lead to prolonged

hospitalization. Prior to surgery, the administration of anesthesia forces the infant's body temperature to decrease. A study on infants undergoing surgery estimated that anaesthesia without any temperature correction would cause the body temperature to drop an average of 2.1°C (Onalo, 2014). Even small drops in body temperature of 1°C can cause adverse effects in infants. Furthermore, anesthesia has inhibitory effects on autonomous temperature regulatory mechanisms.

Design objective

The objective set by a team of research collaborators from Northwestern University, Evanston, USA and the University of Ibadan, Nigeria, was to design a safe and affordable way to maintain appropriate infant temperature during open abdominal surgery at the UCH. The device is intended for infants with body mass between 1.5 and 3.5 kg. As previously mentioned, there are four methods of heat loss in infants: radiation, conduction, convection, and evaporation. The design of the warming device was based on using the principles of conduction and convection to combat the heat loss that occurs during surgery by placing the infant on top of a warm heating pad. When an infant is placed on a pad that is warmer than the infant's body temperature, there is heat transfer from the surface of the pad to the infant, keeping the baby warm. Using fans within the heating pad, convection disperses the heat from point sources more evenly throughout the surface.

Use environment and users

The user environment for the prototype baby warmer is the UCH in Ibadan, Nigeria. The UCH is one of largest hospitals in Nigeria with 850 beds and 165 examination couches. Paediatricians perform up to 15 major abdominal surgeries on infant patients each week. The hospital needs approximately 40 warming mats for abdominal surgery, other types of surgeries, and post-operative recovery. The warming device is to be used on infants during abdominal surgeries. Since the infants would be under anesthesia during surgery, they were not considered the primary users of the device.

The primary users are doctors, including surgeons and the anesthesiologists, and nurses. The surgeon must be able to complete the abdominal surgery properly without any obstruction or hindrance from the warming device, while the anesthesiologist must have access to device feedback at all times. It was considered important that the temperature readout be visible even at a distance of 60 cm (two feet) away from the device. Another important factor was ease of use in setting up, cleaning, and maintaining the device. While the primary users influenced the bulk of the form and function of the warming device, the secondary users including manufacturers and distributors also had an impact on the product design. The device should be easy to manufacture and shipped across countries and continents.

Design considerations

The following design requirements were considered in consultation with the operating room staff for the development of the warming device.

Portability: Since it was anticipated that the device would be transported by nurses from the operating theatre to the recovery area after each surgery, it was resolved that the device should be so light in weight that it could be easily moved and carried by a single individual. The maximum weight was set at 18 kg (40 lbs.).

Affordability: To create a financially feasible device the budget was set at \$300 per device.

Sanitation: The entire device must be easily cleaned and sanitized between each surgery. This applies not only to the body of the device, but also to the control pad.

Safety: The device must ensure infant safety by integrating safety features and failsafes to prevent any thermal, electrical or mechanical failures.

Adjustability: To account for fluctuating operating room temperature and infant body temperature, the device must operate between 32 and 43°C.

User-friendliness: To allow for ease of use by nurses and anesthesiologists, the temperature controls should be intuitive. Also, the device must display temperature readings to allow anesthesiologists and nurses to make necessary adjustments.

Quick setup: To allow for seamless integration into current operating room procedures, device setup and heating to the desired temperature must be accomplished in less than 15 minutes, as stated by consultant paediatricians at UCH, Ibadan.

Heating technology assessment

Several heating technologies currently being used in medical grade products were assessed. Water mattresses were eliminated from the design consideration because they are heavy, bulky, and prone to leaking, which defied the design requirement of portability. Forced-air warming technology was cost-prohibitive, and thus not considered, despite being the current medical standard in developed countries. A systemic fluid warming technology which warms intravenous fluid entering the patient was considered to be outside the scope of the project because its uses are primarily for cardiac surgery and severe accidental hypothermia and it is invasive. Radiant heating technology such as an incubator was also eliminated due to the fact that it loses heat to its surroundings and obstructs access to the infant.

After completion of the technology assessment, a decision was taken to focus on the design of an electrically powered heating element that would not warm the surroundings and would not require consumables. This choice offered more flexibility for choosing a heating technology that could be integrated well into the body of the device.

Warming pad prototype one

The first warming pad prototype developed in 2016 is shown in Figure 1. Each heating pad consisted of top and bottom covers, a heating element, a temperature sensor and foam insulation. The resistive heating element is covered by an appropriate plastic material for protection from extremely reactive chemicals such as iodine. The foam insulation underneath the heater ensures most of the heat is thermally conducted up towards the infant. The bottom layer seals and protects the internal components. When heating, each pad emits approximately 27 watts, enough to heat the area to the desired temperature in less than 15 minutes. A microcontroller controls the logic and software of the temperature controller. It receives feedback from a waterproof temperature sensor located inside the top pad and displays the temperature on an LCD Screen. It can adjust the power of the pads using a potentiometer located inside the temperature sensor.

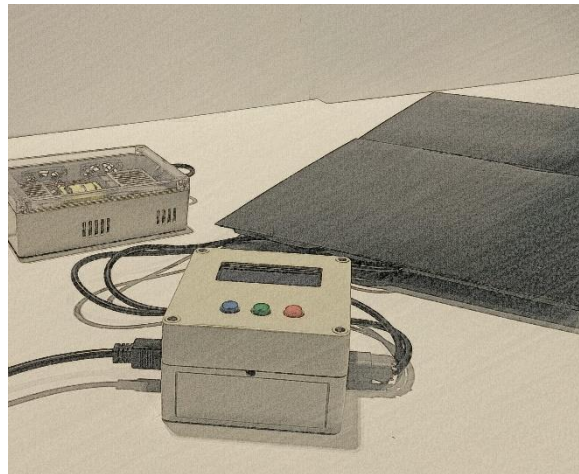

Figure 1: Warming pad prototype one

Preliminary evaluation by consultant paediatricians at UCH revealed that the warming device was too heavy and difficult to transport. Furthermore, the cost of supplies alone for the single prototype (excluding manufacturing cost) was approximately \$310, which exceeded the set budget of \$300. It was necessary to revise the design to remedy these problems.

Warming pad prototype two

The warming pad Prototype Two design was implemented using a foldable fabric design as shown in Figure 2. The fully rigid casing used in the first prototype was first considered again. However, it would require manufacturing processes such as vacuum forming which could consume about one-third of the allotted budget of \$300 set for the device. Though this price would decrease with

mass production, the primary concern was the weight of the rigid HDPE polyethylene. Thus, further ideas were explored since a hard casing might not mitigate the clients' previous concerns about high weight and low portability.



Figure 2: Warming pad prototype two

Therefore, the idea of a soft casing and a foldable fabric design was adopted. Above the heating element and sensors was placed a thin layer of polyethylene electrical insulation and vinyl foam. The bottom-most layer is a rigid polyurethane thermal insulation material with a relatively low thermal conductivity constant of 0.03 W (mK)^{-1} , which prevents heat loss through the bottom of the device while providing structural strength. The material is lightweight and low cost at \$25 per device, lending to the portability and affordability of the device. The electrical element is insulated with lightweight polyethylene film as a safety feature to separate the infant from any electrical currents. Furthermore, the film costs only \$3 per device. To keep the inner components together, the entire stack of components was wrapped with a polyethylene stretch wrap. This method addressed not only the lightweight issue but also cost effectiveness.

The electronic components of the device allow real-time temperature monitoring and control. The device has two temperature sensors placed above the heating element and below the polyethylene electronic insulation, near the intended positions for the shoulders and buttocks of the infant. A microcontroller reads the temperature sensor output from the sensors and then adjusts the voltage across the heating element to control the device temperature in real-time.

Safety features were incorporated into the device to protect the heating element from power surges. The sharp increase in voltage or current during a power surge can cause too high current to run through and damage the heating element. The operating rooms at UCH are powered by 220-240 V wall outlets. However, Nigeria has a serious deficit with provision of power and has been known to have power outage for up to 14.5 hours a day. As a result, most hospitals that conduct surgeries have backup generators that may result in power surges. Therefore, it is important to cut current through the heating element during a power surge. A watchdog microcontroller was installed which detects current going through the heating element and cuts power to the heating element if the current exceeds a set threshold. In addition, the temperature sensors could be damaged by electrostatic discharge, which is a sudden flow of electricity that can produce high voltages. Therefore, an electrostatic discharge protection diode was installed.

The component cost of the second prototype was \$186, which was within the set budget of \$300. This cost, however, excludes potential labour and facility costs that would be incurred during manufacturing. The manufacturing cost is yet to be fully determined.

Conclusion

Two prototypes of a low-cost and portable surgical warming pad have been developed for potential deployment in a typical neonatal surgical ward in developing countries. The second prototype provides adjustable heat production throughout surgery and postoperative recovery and is easily set-up and cleaned. In addition, it serves as a comfortable surface for infant patients and is lightweight and foldable to enhance portability. Optimizing manufacturing costs for the device and meeting government regulations are under consideration.

Acknowledgement

Research reported in this publication was supported by the Fogarty International Center of the National Institutes of Health under award number D43TW009374.

References

- Al Hammadi, T., Sinha, T., Ahmed, O. K. & Hamouda, S. B., 2005. Hypothermia in infants: the important factors. *Qatar Medical Journal*. 14(2):37–39.
- Day, R.L., Caliguiri, L., Kamenski, C., and Ehrlich, F. 1964. Body temperature and survival of premature infants. *Pediatrics*. 34:171–181.
- IDPH, 2017. *Pediatric and Neonatal Care Guidelines*, Illinois: Illinois ESF-8 Plan: Pediatric and Neonatal Surge Annex.
- Leduc, D. & Woods, S. 2013. *Canadian Paediatric Society – Community Paediatrics Committee Position Statement: temperature measurement in paediatrics*. Available: <http://www.cps.ca/en/documents/position/temperature-measurement> [2019, May 06].
- Onalo, R. 2014. Neonatal hypothermia in sub-Saharan Africa: a review. *Nigerian Journal of Clinical Practice*. (16)2. DOI: 10.4103/1119-3077.110120.
- WHO. 2015. *WHO compendium of innovative health technologies for low-resource settings 2011–2014*. Available: https://www.who.int/medical_devices/innovation/compendium/en/ [2019, May 06].

Chapter 14

Needle Disposal Device for Use in Low-Resource Settings

G. Beukes, C. Achi, B. Bolasodun, A. Desmennu, A. Oloyo,
O. Oyebola, O. Oyewola, T. Saidi, A.O. Coker & S. Sivarasu

Introduction

Used needles pose serious risks of injury to health care workers and non-medical staff who handle the waste, as well as to the general population. The safe disposal of needles and syringes used for the collection of blood and other bodily fluids and for injections is important in preventing needle stick injuries, which can cause the transmission of a variety of blood-borne pathogens such as hepatitis B virus, hepatitis C virus, and human immunodeficiency virus (Lavoie et al., 2014; Balouchi et al., 2015; Jahangiri et al., 2016). Infections occur when accidental punctures by contaminated needles inject hazardous fluids into the body through the skin, leading to chronic and fatal diseases (Lavoie et al., 2014). According to the World Health Organisation (WHO), it is estimated that among the 35 million health care workers worldwide, approximately 3 million receive percutaneous exposures to blood-borne pathogens each year, with 2 million being prone to the hepatitis B virus, 0.9 million to the hepatitis C virus and 170,000 to the human immunodeficiency virus (WHO, 2002). The degree of exposure is more pronounced in developing countries where poor handling and disposal of used sharps contribute significantly to needle stick injuries (Chalupka et al., 2008, Shoghli et al., 2013). In developing countries, the disposal of contaminated sharps is also a serious safety concern for garbage collectors and landfill workers (Patwary, O'Hare & Sarker, 2012).

Various mechanisms have been proposed to prevent needle stick injuries. For example, the WHO recommends the use of sharp disposal containers for getting rid of unwanted needles (Diaz, Savage & Eggerth, 2005, Perry et al., 2012). The use of dedicated containers for the disposal of needles can reduce needle stick injuries in health care settings (Hatcher, 2002). However, the effectiveness of safety boxes is limited to the point of use as the needles should be subjected to further treatment for disposal. There are risks of injury that arise during and after final disposal of needles, particularly in places that are accessible to the public (Ziraba, Haregu & Mberu, 2016). The unsanitary disposal of needles put millions of lives at risk because dumping sites are often visited by people scavenging for goods, resulting in accidental exposure (Salkin & Kennedy, 2001; Diaz, Savage & Eggerth, 2005; Wilson, Velis & Cheeseman, 2006). This calls for innovative strategies of preventing needle stick injuries. There are growing calls for cradle-to-grave responsibilities in the management of needles (Gold, 2011). It is against this background that this chapter focuses on the design and development of a portable, cost-effective and energy-efficient needle disposal device for use in low-resource settings.

Disposal in developed countries

Globally, there are many methods for processing and disposing of used needles and other sharps generated by health care facilities. In developed countries, sharp disposable containers are commonly used (Nagao et al., 2007; Alamgir et al., 2008; Lavoie et al., 2014). For example, the use of sharp disposal containers in the USA can be traced to 1983 when the Center for Disease Control and Prevention recommended their use (CDC, 1987; Perry et al., 2012). In Europe, the European Union directive endorses the use of clearly marked and technically safe containers for the handling of disposable sharps and injection equipment as close as possible to the areas where sharps are used (EU, 2010). In Japan, regulations encourage the use of sharp disposal containers in areas where needles are frequently used such as operating rooms, treatment rooms and centrally located areas of wards (Nagao et al., 2007). Sharp disposable containers have evolved over the last decades to include features such as increased puncture resistance, one-way openings, and signifiers to prevent overfilling, such as a line that indicates when the container should be considered full (Perry et al., 2012). For sharp disposable containers to be effective, the minimum design and performance requirements include that they be easily accessible to personnel and located as close as is feasible to the immediate area where sharps are used or can be reasonably anticipated to be found (Domin & Smith, 1992). In addition, the containment system should be of heavy duty and leak resistant plastic with a tight-fitting, puncture-resistant lid which is conspicuously labelled to warn of hazardous waste inside the container (Blackman Jr, 2016). It is recommended that safety boxes only be filled once and disposed of (WHO, 2005). There is no one prescribed method for the disposal of safety boxes, but any selected method must be in compliance with national and local environmental regulations (WHO, 2002).

Sharp disposable containers are a temporary storage for used needles before their final disposal. The process of disposing of full sharp containers is a critical part of waste management which must be clearly delineated and enforced (Perry et al., 2012). Several technologies are used to treat and dispose of sharps stored in sharp containers; these include incineration, chemical disinfection, wet thermal treatment, and microwave irradiation (Chaerul, Tanaka & Shekdar, 2008). In order to prevent infections, the collection and disposal of the sharps container is subject to special safety requirements to avoid contamination (Hester & Harrison, 2002). Some are disposed of by high temperature incineration, while others are transported to a dump site (Mühlich, Scherrer & Daschner, 2003). Although incineration is a relatively costly treatment, it is widely used in developed countries as it is effective (Chaerul, Tanaka & Shekdar, 2008). Developed countries can afford to use high-technology incinerators to achieve complete combustion and to keep the concentration of undesirable waste compounds generated by burning to a minimum (Diaz, Savage & Eggerth, 2005). Countries such as the USA, Canada and Japan have a regulated waste disposal system where sharps are transported for disposal at dump sites that are kept out of reach of the public (Nagao et al., 2007; Alamgir et al., 2008; Perry et al., 2012). In these countries, the sharp disposal containers are collected and transported separately from other medical waste to avoid compaction and facilitate separate treatment (Mühlich, Scherrer & Daschner, 2003). The sharps

are encapsulated by placing them in containers made of cardboard, plastic, or metal which are immobilised using cement, plastic foams, resins or clay (WHO, 2005). Once the immobilising material has hardened, the containers are sealed and disposed of in a dedicated disposal site as encapsulation keeps personnel in the waste management system from being injured (Diaz, Savage & Eggerth, 2005). In addition, developed countries have adopted engineering controls such as safer needle devices which blunt, sheath, or retract the needle immediately after use (Wilburn & Eijkemans, 2004). Such devices have been shown to reduce needle stick injuries (Jagger, 1996; Weese & Jack, 2008).

Disposal in developing countries

In developing countries, sharps are a cause for concern because of inappropriate treatment and disposal practices (Diaz, Savage & Eggerth, 2005, Sawalem, Selic & Herbell, 2009). For example, sharps disposal containers, incinerators and transportation networks are not always available (Mbongwe, Mmereki & Magashula, 2008). Cost constraints make the purchase of single use disposable containers unrealistic. This often results in improvised makeshift containers which pose a health hazard (Nsubuga & Jaakkola, 2005, Patwary, O'Hare & Sarker, 2011). Studies that were conducted in Uganda, Tanzania and the Dominican Republic revealed that used sharps were discarded in ad-hoc puncture-proof containers, rather than in boxes designed specifically for sharps (Muller, 2005; Moro et al., 2007; Manyele, Samwel V & Mujuni, 2010). The boxes were overfilled resulting in sharps on the floor and in areas surrounding the health facilities. The disposal of sharps in the garbage expose children and waste handlers to risk of injuries and transmission of blood-borne pathogens (Manyele, SV & Lyasenga, 2010; Ishtiaq et al., 2012; Gyawali et al., 2013).

In many parts of Africa, medical waste including sharps is not separated from municipal waste but is collected along with the rest of the waste stream (Kgathi & Bolaane, 2001, Manyele, 2004, Taru & Kuvarega, 2005). Sharps containers may be placed in less secure storage facilities, which often results in contaminated injection equipment being scavenged and reused (Salkin & Kennedy, 2001; Mbongwe, Mmereki & Magashula, 2008; Rachiotis et al., 2012). In many developing countries, medical waste, and in particular used syringes and needles, are commonly burned in the open air or in simple and often improvised units such as pits, burners (made out of brick or cement), and in drums (Diaz, Savage & Eggerth, 2005). Although the units are relatively inexpensive, easy to build, and require little or no maintenance, they are not effective in the disposal of sharps because of the relatively uncontrolled combustion conditions (Diaz, Savage & Eggerth, 2005, Sawalem, Selic & Herbell, 2009). As a result, combustion does not completely burn all of the waste, particularly if it has a relatively high moisture content (Diaz, Savage & Eggerth, 2005). Another option for disposing sharps in developing countries is the use of open dumps (Longe & Williams, 2006). While being the least costly option, the use of open dumps poses negative impacts to the public and environment because of the uncontrolled nature of disposal (Sawalem, Selic & Herbell, 2009).

Many factors militate against the safe disposal of sharps in developing countries. Medical waste management has not received sufficient attention in developing countries due to limited financial, physical and human resources (Harhay et al., 2009; Awodele, Adewoye & Oparah, 2016). Poor roads, intermittent electricity, lack of vehicles which makes transportation of waste unsafe, and the absence of effective municipal waste disposal systems are contributing factors (Abah & Ohimain, 2011; Patwary, O'Hare & Sarker, 2011; Guerrero, Maas & Hogland, 2013). Transportation of sharps to dump sites is problematic in areas without proper means of transport (Chaerul, Tanaka & Shekdar, 2008), resulting in medical waste being transported on foot and by hand, thereby increasing the danger of the waste handler being accidentally pierced or cut by contaminated sharps (Tsakona, Anagnostopoulou & Gidarakos, 2007). Lack of awareness about the health hazards related to medical waste and inadequate training in proper waste management contributes to poor disposal of waste (Abah & Ohimain, 2010; Mathur et al., 2011; Madhukumar & Ramesh, 2012).

Engineering controls such as safe needle devices are expensive for developing countries and they cannot afford to adopt such risk reduction innovations without financial assistance (Ekwueme, Weniger & Chen, 2002). The problem is compounded by the rising amount of hospital waste generated due to growth of the population and increased numbers of health care facilities (Awodele, Adewoye & Oparah, 2016). As a result, the sharps are deposited openly in waste dumps and surrounding environments, often alongside non-hazardous solid waste as there are no systematic approaches to medical waste management (Abah & Ohimain, 2011; Awodele, Adewoye & Oparah, 2016; Macaulay & Odiase, 2016). Studies on medical waste management in Lagos, Dar es Salaam and Dhaka revealed that burning and burial of medical waste was a common practice at hospitals due to limited options (Mato & Kaseva, 1999; Longe & Williams, 2006; Hassan et al., 2008).

A needle disposal device for low-resource settings

A safe, simple, on-the-counter, needle disposal device that would effectively leave the needle unusable (by bending, breaking, crushing or cutting it) and allow for needles to be disposed of with medical grade waste would assist in preventing needle stick injuries at health care facilities and in reducing the dumping of used needles at inappropriate public locations. This section presents the design of such a device for destruction of the needle at the point of use, based on a need identified by academics from the University of Ibadan. While public hospitals and primary healthcare clinics in Nigeria were identified as potential users of the device, similar facilities in other developing countries would also benefit.

User requirements

The requirements for the device, based on the needs of potential users, are outlined below.

- The needle is separated from the syringe so that the metal and non-metal components are disposed of separately.
- The needle is rendered unusable and is left in a form that makes it easily disposable.
- Operability:
 - The device is comfortable to operate by a healthcare worker.
 - Electricity-driven operation ensures maximal ease of use.
 - A manual mode is available for instances where automation is not possible, for example due to interruption in the power supply.
- The device has a universal attachment for mounting to a variety of counter tops.
- The device has a detachable needle container for ease of disposal.
- The device prevents accidental contact between the needles and operator once separation is achieved.
- The device is easily cleaned and maintained.

Design

The device has three subsystems:

1. Needle separator
2. Needle cutter
3. Container/housing with separator for plastic and metal

Needle separator

The separator mechanism (as illustrated in Figure 1) makes use of a rhombus/diamond shaped separator, which allows the operator to insert the needle and syringe assembly and slide it in either direction to achieve separation. A separation area thickness of 0.75 mm was considered sufficient in terms of strength and separation distance between the needle plastic and the syringe. In addition, the separator needed to funnel the needle into the point of destruction. This is achieved by embedding a funnel into the separator to ensure that the needle falls directly onto the point of destruction, thereby increasing the effectiveness of the cutting mechanism. The separator was manufactured by means of a fused deposition modelling (FDM) three-dimensional (3D) printer. The material selected for the component was acrylonitrile butadiene styrene (ABS) polymer. The material is commonly used for 3D printing due to its affordability and low melting temperature (200°C–238°C). The funnel system is indicated in Figure 1.

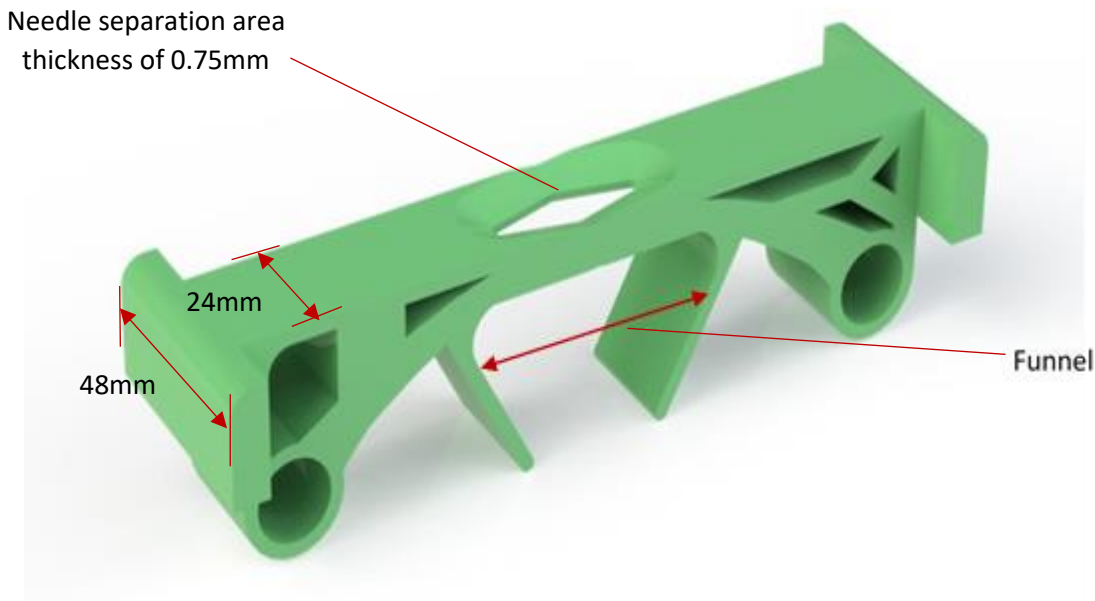

Figure 1: Needle separator with funnel to guide the needle towards the cutter for destruction.

Needle cutter

The needle cutter aims to cut the needles to achieve complete destruction. Needle cutting was achieved using a unit comprising a uni-rotating shaft and a stationary shaft. The rotating shaft comprises four rotating cutters featuring twelve teeth each, with spacer disks between the cutters. The stationary shaft supports four stationary cutters featuring four teeth and a spacer disk between the cutters. Each stationary cutter lines up with a spacer between the rotating cutters. This is illustrated in Figure 2. The stationary cutters produce the necessary shear that would cut the needles.

In addition, a gearing system reduces the force required to rotate the cutter gears and create the required cutting effect. The gearing system uses an idle pinion gear fitted to the stationary cutter shaft. The larger gear is fitted to the rotating shaft by means of a key. This ensures that the torque generated would be transferred to the rotating cutters. The gearing system allows, by the spacing of the shafts as well as the dimensions of the device, for a torque ratio of 1:2.375, which reduces the torque required to cut the needles by a factor of 2.375. Manually applied torque is sufficient to destroy the needles. The device features an attachment that allows for secure fitment of a power drill to drive the gearing system, as well as a crank, should electrical operation not be possible. The gearing system is shown in Figure 3.

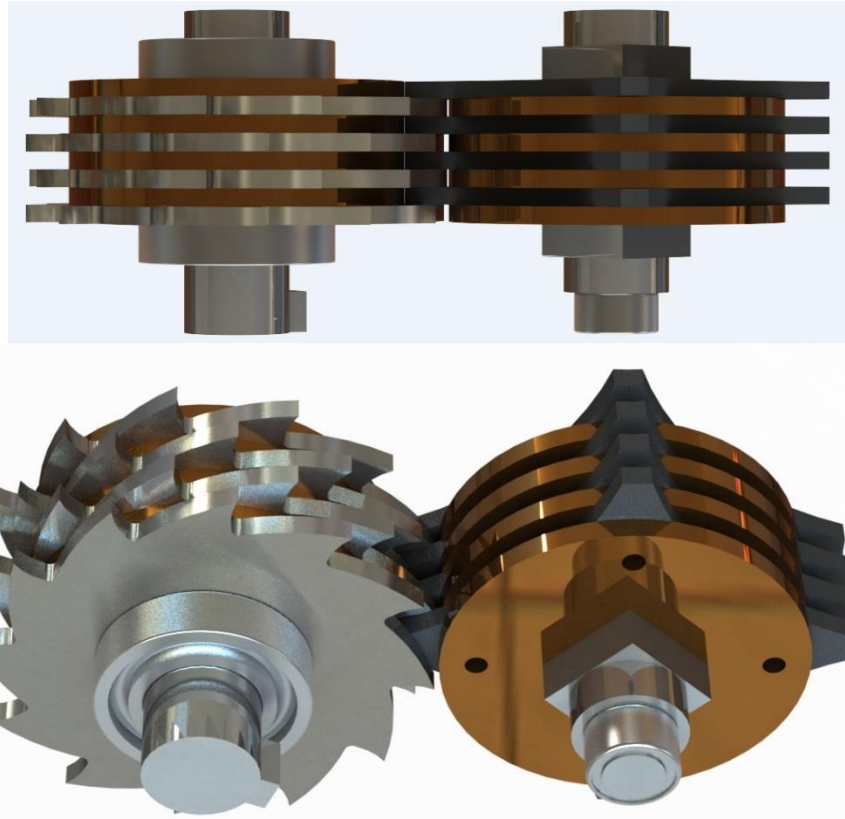

Figure 2: Needle cutter. Left: rotating cutters separated by spacers; Right: stationary cutters separated by spacers.

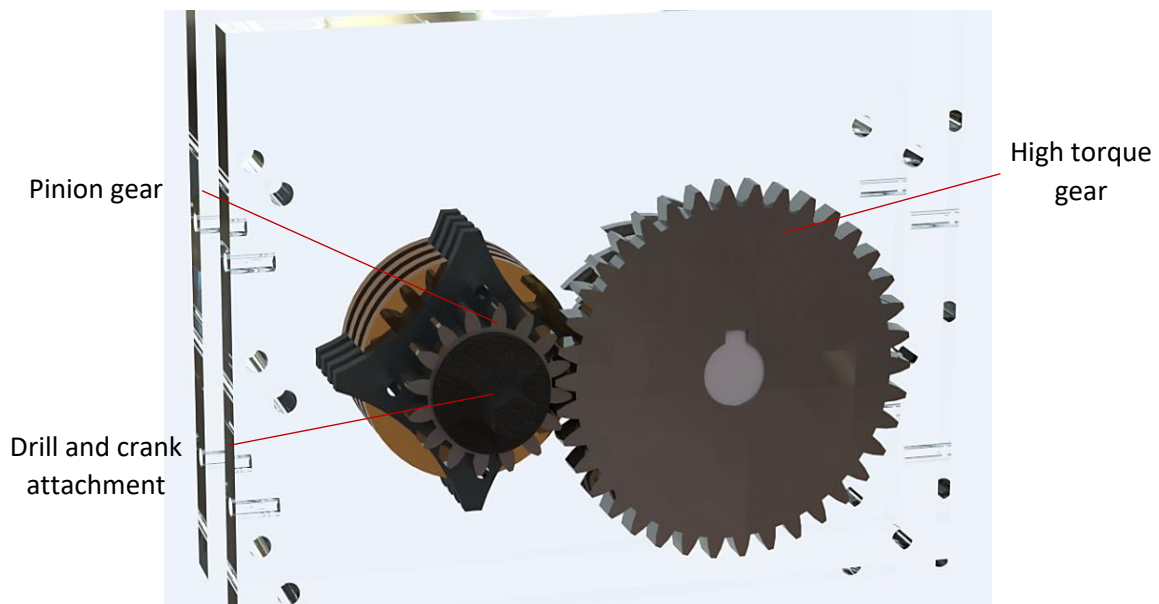

Figure 3: Gearing system to drive the cutter.

The cutter and spacers were manufactured from tungsten steel by a commercial company, using wire electrical discharge machining, and hardened for durability.

The rear plate of the cutter housing was machined from a $160 \times 125 \times 8$ mm aluminium sheet, in order to counteract the reaction torque and other forces experienced during the needle cutting procedure. The front plate was manufactured from a $160 \times 125 \times 8$ mm sheet of Plexiglas® allowing for visualisation of the needle cutting process. Each shaft was manufactured from stainless steel due to the stresses involved. A hexagonal shaft was used for the rotating cutters and a cubic shaft for the stationary cutters. This eliminated the need for keys to fixate the cutters. As previously mentioned, the cutters were all machined out of tungsten steel and hardened to ensure strength and longevity.

Container with separator for plastic and metal

A mechanism to separate the cut plastic from the cut needle was a requirement to allow for materials to be recycled. The 3D printed plastic container was manufactured from Zortrax Ultra-T Ivory plastic. The material is specifically designed for the Zortrax M-200 3D printer and is durable as well as capable of producing highly detailed prints. Chemical degradation and heat were considered for the separation of plastic, but were found to be too expensive, particularly in the case of rural clinics in Nigeria. Instead, a magnetic means was selected to separate the metal from the plastic. Two rare earth neodymium rectangular magnets ($50 \times 20 \times 6$ mm) were embedded in polymer housing (see Figure 4) and placed below the cutting mechanism. Once the needle has been cut up, the metal pieces would be caught by the magnets and the plastic would slide to the bottom of the container. Upon opening the container, the plastic can be collected and the metal pieces scraped off the magnets.

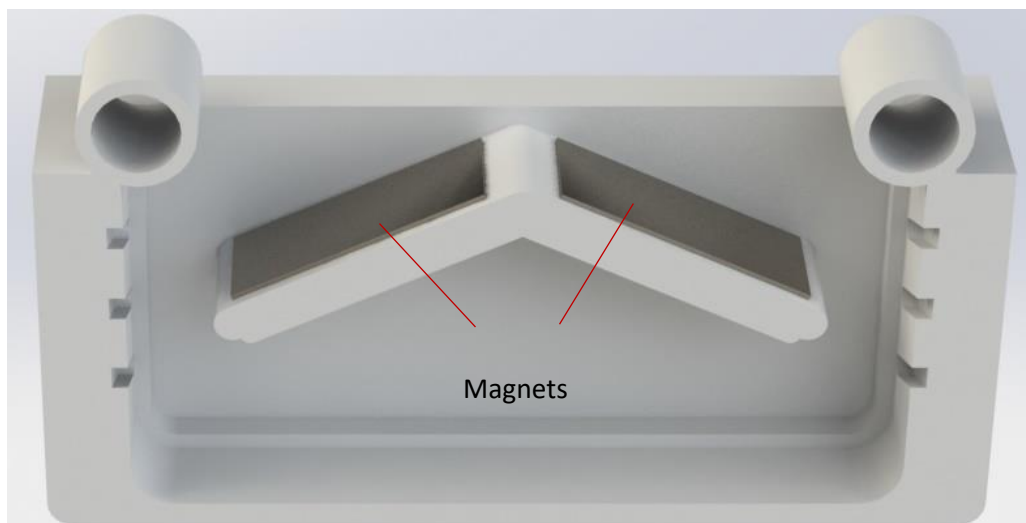

Figure 4: Container for destroyed needles, with magnetic (neodymium) separation.

The complete needle disposal device is shown in Figure 5.

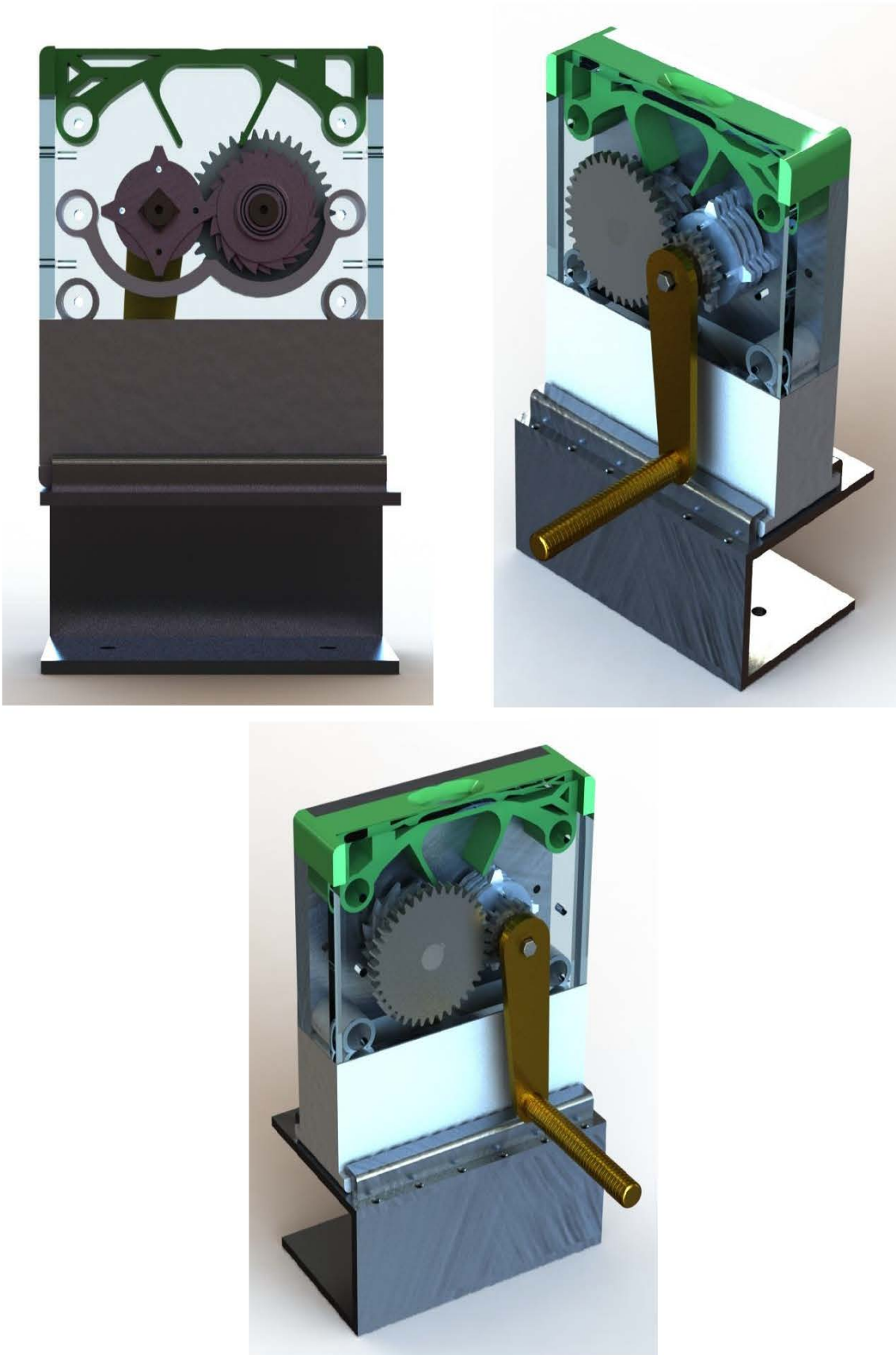

Figure 5: Needle disposal device.

Cost breakdown for one device

The total cost for the manufacture of the device was approximately ZAR 5,000, broken down as follows:

- Cutters – ZAR 3000 (material and manufacturing)
- 3D plastic:
 - Separator: ZAR 70
 - Base 1: ZAR 140
 - Base 2: ZAR 100
- Plexiglass:
 - Side plates: ZAR 20
 - Front plate: ZAR 40
- Gears: ZAR300
- Shafts: ZAR100
- Brass handle: ZAR 150
- Aluminium
 - Fixator: ZAR 240
 - Back plate: ZAR 100
- Magnets: ZAR 280 (ZAR140 each)
- Bearings: ZAR 200

Conclusion

The device allows clinical staff to dispose of and destroy needles at point of use, addressing the problem of needle stick injuries among hospital staff and the public. It allows for the recycling of materials. It is compact and designed to be affordable (approximately R5000 or Naira 135,000 per device by small scale manufacturing), therefore allowing for implementation in low-resource settings.

Acknowledgements

The authors are grateful to Charles Harris and Tyrone de Wet from the Mechanical Workshop of the Department of Human Biology, University of Cape Town, for their design and manufacturing contributions.

Research reported in this publication was supported by the Fogarty International Center of the National Institutes of Health under award number D43TW009374.

References

- Abah, S.O. & Ohimain, E.I. 2010. Assessment of dumpsite rehabilitation potential using the integrated risk-based approach: a case study of Eneka, Nigeria. *World Applied Sciences Journal*. 8(4):436–442.
- Abah, S.O. & Ohimain, E.I. 2011. Healthcare waste management in Nigeria: a case study. *Journal of Public Health and Epidemiology*. 3(3):99–110.
- Alamgir, H., Cvitkovich, Y., Astrakianakis, G., Yu, S. & Yassi, A. 2008. Needlestick and other potential blood and body fluid exposures among health care workers in British Columbia, Canada. *American Journal of Infection Control*. 36(1):12–21.
- Awodele, O., Adewoye, A.A. & Oparah, A.C. 2016. Assessment of medical waste management in seven hospitals in Lagos, Nigeria. *BMC Public Health*. 16(1):269.
- Balouchi, A., Shahdadi, H., Ahmadidarrehshima, S. & Rafiemanesh, H. 2015. The frequency, causes and prevention of needlestick injuries in nurses of Kerman: a cross-sectional study. *Journal of Clinical and Diagnostic Research*. 9(12):DC13.
- Blackman Jr, W.C. 2016. *Basic hazardous waste management*. Boca Raton, FL: CRC Press.
- CDC. 1987. *Recommendations for prevention of HIV transmission in health-care settings*. Atlanta, GA: Centres for Disease Control.
- Chaerul, M., Tanaka, M. & Shekdar, A.V. 2008. A system dynamics approach for hospital waste management. *Waste Management*. 28(2):442–449.
- Chalupka, S.M., Markkanen, P., Galligan, C. & Quinn, M. 2008. Sharps injuries and bloodborne pathogen exposures in home health care. *AAOHN Journal: Official Journal of the American Association of Occupational Health Nurses*. 56(1):15–32.
- Diaz, L., Savage, G. & Eggerth, L. 2005. Alternatives for the treatment and disposal of healthcare wastes in developing countries. *Waste Management*. 25(6):626–637.
- Domin, M. & Smith, C. 1992. OSHA's final rule on occupational exposure to bloodborne pathogens. *Journal of Healthcare Materiel Management*. 10(2):36, 38, 40 passim.
- Ekwueme, D.U., Weniger, B.G. & Chen, R.T. 2002. Model-based estimates of risks of disease transmission and economic costs of seven injection devices in sub-Saharan Africa. *Bulletin of the World Health Organization*. 80(11):859–870.
- EU. 2010. Implementing the framework agreement on prevention from sharps injuries in the hospital and health care sector. *Official Journal of European Union*. 53 (L134): 66–72.
- EU-OSHA. 2010. Implementing the framework agreement on prevention from sharps injuries in the hospital and health care sector, concluded by HOSPEEM and EPSU. Available: <https://osha.europa.eu/en/legislation/guidelines/framework-agreement-on-prevention-from-sharp-injuries-in-the-hospital-and-healthcare> [2019, May 06].
- Gold, K. 2011. Analysis: The impact of needle, syringe, and lancet disposal on the community. *Journal of Diabetes Science and Technology*. 5(4): 848–850.
- Guerrero, L.A., Maas, G. & Hogland, W. 2013. Solid waste management challenges for cities in developing countries. *Waste Management*. 33(1):220–232.
- Gyawali, S., Rathore, D.S., Bhuvan, K. & Shankar, P.R. 2013. Study of status of safe injection practice and knowledge regarding injection safety among primary health care workers in Baglung district, western Nepal. *BMC International Health and Human Rights*. 13(1):3.
- Harhay, M.O., Halpern, S.D., Harhay, J.S. & Olliaro, P.L. 2009. Health care waste management: a neglected and growing public health problem worldwide. *Tropical Medicine & International Health*. 14(11):1414–1417.
- Hassan, M.M., Ahmed, S.A., Rahman, K.A. & Biswas, T.K. 2008. Pattern of medical waste management: existing scenario in Dhaka City, Bangladesh. *BMC Public Health*. 8(1):36.
- Hatcher, I.B. 2002. Reducing sharps injuries among health care workers: a sharps container quality improvement project. *The Joint Commission Journal on Quality Improvement*. 28(7):410–414.

- Hester, R.E. & Harrison, R.M. 2002. *Environmental and health impact of solid waste management activities*. Royal Society of Chemistry. DOI: <https://doi.org/10.1039/9781847550767>
- Ishtiaq, O., Qadri, A.M., Mehar, S., Gondal, G.M., Iqbal, T., Ali, S. & Janjua, N.Z. 2012. Disposal of syringes, needles, and lancets used by diabetic patients in Pakistan. *Journal of Infection and Public Health*. 5(2):182–188.
- Jagger, J. 1996. Reducing occupational exposure to bloodborne pathogens: where do we stand a decade later? *Infection Control and Hospital Epidemiology*. 17(9):573–575.
- Jahangiri, M., Rostamabadi, A., Hoboubi, N., Tadayon, N. & Soleimani, A. 2016. Needle stick injuries and their related safety measures among nurses in a university hospital, Shiraz, Iran. *Safety and Health at Work*. 7(1):72–77.
- Kgathi, D. & Bolaane, B. 2001. Instruments for sustainable solid waste management in Botswana. *Waste Management & Research*. 19(4):342–353.
- Lavoie, M. C., Verbeek, J. H. & Pahwa, M. 2014. Devices for preventing percutaneous exposure injuries caused by needles in healthcare personnel. *Cochrane Database of Systematic Reviews*, Issue 3, Article No. CD009740: 1–76.
- Longe, E. & Williams, A. 2006. A preliminary study of medical waste management in Lagos metropolis, Nigeria. *Journal of Environmental Health Science & Engineering*. 3(2):133–139.
- Reddy V.K., Lavoie, M.C., Verbeek, J.H., Parantainen, A. & Pahwa, M. 2012. Devices for preventing percutaneous exposure injuries caused by needles in health care personnel. *Cochrane Database of Systematic Reviews*. 11: CD009740. DOI: 10.1002/14651858.CD009740.pub3.
- Macaulay, B.M. & Odiase, F.M. 2016. Medical waste management practices in developing countries: a case study of health facilities in Akure, Nigeria. *International Journal of Environment and Waste Management*. 17(2):103–127.
- Madhukumar, S. & Ramesh, G. 2012. Study about awareness and practices about health care waste management among hospital staff in a medical college hospital, Bangalore. *Iranian Journal of Basic Medical Sciences*. 3(1):7–11.
- Manyele, S. 2004. Effects of improper hospital-waste management on occupational health and safety. *African Newsletter on Occupational Health and Safety*. 14(2):30–33.
- Manyele, S. & Lyasenga, T. 2010. Factors affecting medical waste management in lowlevel health facilities in Tanzania SV. *African Journal of Environmental Science and Technology*. 4(5).
- Manyele, S.V. & Mujuni, C.M. 2010. Current status of sharps waste management in the lower-level health facilities in Tanzania. *Tanzania Journal of Health Research*. 12(4):257–264.
- Mathur, V., Dwivedi, S., Hassan, M. & Misra, R. 2011. Knowledge, attitude, and practices about biomedical waste management among healthcare personnel: a cross-sectional study. *Indian Journal of Community Medicine*. 36(2):143.
- Mato, R. & Kaseva, M. 1999. Critical review of industrial and medical waste practices in Dar es Salaam City. *Resources, Conservation and Recycling*. 25(3):271–287.
- Mbongwe, B., Mmereki, B.T. & Magashula, A. 2008. Healthcare waste management: current practices in selected healthcare facilities, Botswana. *Waste Management*. 28(1):226–233.
- Moro, P.L., Moore, A., Balcacer, P., Montero, A., Diaz, D., Gómez, V., Garib, Z. & Weniger, B.G. 2007. Epidemiology of needlesticks and other sharps injuries and injection safety practices in the Dominican Republic. *American Journal of Infection Control*. 35(8):552–559.
- Mühlich, M., Scherrer, M. & Daschner, F. 2003. Comparison of infectious waste management in European hospitals. *Journal of Hospital Infection*. 55(4):260–268.
- Muller, N. 2005. *Evaluation of a disposable needle-removal device in Uganda*. Seattle, WA: United States Agency for International Development (USAID).
- Nagao, Y., Baba, H., Torii, K., Nagao, M., Hatakeyama, K., Iinuma, Y., Ichiyama, S., Shimokata, K. et al. 2007. A long-term study of sharps injuries among health care workers in Japan. *American Journal of Infection Control*. 35(6):407–411.
- Nsubuga, F.M. & Jaakkola, M.S. 2005. Needle stick injuries among nurses in sub-Saharan Africa. *Tropical Medicine & International Health*. 10(8):773–781.

- Patwary, M.A., O'Hare, W.T. & Sarker, M.H. 2011. Assessment of occupational and environmental safety associated with medical waste disposal in developing countries: a qualitative approach. *Safety Science*. 49(8):1200–1207. DOI: 10.1016/j.ssci.2011.04.001.
- Patwary, M.A., O'Hare, W.T. & Sarker, M.H. 2012. Occupational accident: an example of fatalistic beliefs among medical waste workers in Bangladesh. *Safety Science*. 50(1):76–82. DOI: 10.1016/j.ssci.2011.07.004.
- Perry, J., Jagger, J., Parker, G., Phillips, E.K. & Gomaa, A. 2012. Disposal of sharps medical waste in the United States: impact of recommendations and regulations, 1987–2007. *American Journal of Infection Control*. 40(4):354–358.
- Rachiotis, G., Papagiannis, D., Markas, D., Thanasias, E., Dounias, G. & Hadjichristodoulou, C. 2012. Hepatitis B virus infection and waste collection: prevalence, risk factors, and infection pathway. *American Journal of Industrial Medicine*. 55(7):650–655.
- Salkin, I.F. & Kennedy, M. 2001. *Review of health impacts from microbiological hazards in health-care wastes*. Available: https://www.who.int/water_sanitation_health/medicalwaste/en/microbhazards0306.pdf [2019, May 06].
- Sawalem, M., Selic, E. & Herbell, J.-D. 2009. Hospital waste management in Libya: a case study. *Waste Management*. 29(4):1370–1375.
- Shoghli, A., Mousavi Nasab, N., Ghorchian, F., Masoumi, H. & Momtazi, S. 2013. Study of the Needle Sticks Injury (NSI) among the Zanjan Educational Hospitals Staff. *ZUMS Journal*. 21(85):131–141.
- Taru, P. & Kuvarega, A.T. 2005. Solid medical waste management. The case of Parirenyatwa Hospital, Zimbabwe. *Revista Biomédica*. 16(3):153–158.
- Tsakona, M., Anagnostopoulou, E. & Gidarakos, E. 2007. Hospital waste management and toxicity evaluation: a case study. *Waste Management*. 27(7):912–920.
- Weese, J.S. & Jack, D.C. 2008. Needlestick injuries in veterinary medicine. *The Canadian Veterinary Journal*. 49(8):780.
- WHO. 2002. *The World Health Report 2002: reducing risks, promoting healthy life*. Available: <https://www.who.int/whr/2002/en/> Available: [2019, May 06].
- WHO. 2005. *Management of solid health-care waste at primary health-care centres: a decision-making guide*. Available: https://www.who.int/water_sanitation_health/publications/manhcwm.pdf?ua=1 [2019, May 06].
- Wilburn, S.Q. & Eijkemans, G. 2004. Preventing needlestick injuries among healthcare workers: a WHO-ICN collaboration. *International Journal of Occupational and Environmental Health*. 10(4):451–456.
- Wilson, D.C., Velis, C. & Cheeseman, C. 2006. Role of informal sector recycling in waste management in developing countries. *Habitat International*. 30(4):797–808.
- Ziraba, A.K., Haregu, T.N. & Mberu, B. 2016. A review and framework for understanding the potential impact of poor solid waste management on health in developing countries. *Archives of Public Health*. 74(1):55.

Chapter 15

An Electronically Controlled Gravity Feed Infusion Set for Intravenous Fluids

P.N. Makobore & M. Mulerwa

Background

In Africa, particularly Sub-Saharan Africa, access to quality healthcare continues to be a challenge and Uganda is no exception. The healthcare delivery systems remain inadequate to meet the needs of a growing population, raising concerns by policy makers regarding whether health services are being delivered efficiently (OAG, 2015). Unreliable supply chains for medical consumables, expensive medical equipment, irrational use and wide variation in the quality of health technologies are some of the leading challenges (Barry & Pathe, 2008). Medical devices are critical to health care delivery but access to them is often limited in African countries.

The largest hurdle in the Ugandan healthcare system is at the system level. Most of the limitations faced in hospitals are directly correlated with the economic state of the country and the lack of effective and sustainable mechanisms to provide adequate medical supplies and maintain equipment. Infrastructural deficiencies such as unreliable electricity supply and poor roads for transportation further compound the problem. The high clinician-to-patient ratio creates a need for robust automated devices that can alleviate the country-wide problem of limited health workers. The majority of equipment is donated and most of this equipment can be found in hospital dumping yards as a result of frequent breakdown partly due to inaccessibility of spare parts and because the equipment has not been designed for the Ugandan setting.

The Uganda Industrial Research Institute (UIRI) began to focus strategically on the design of innovative solutions to address gaps in the healthcare sector in 2013. UIRI is a centre of excellence for industrial research in the East African Community and a member of the World Association of Industrial and Technological Organizations (WAITRO). It was awarded this status in late 2013 during a heads of state summit held in Kampala, Uganda. The Institute is the Ugandan Government's lead agency for industrialisation, established by a Uganda Act of Parliament, under the auspices of the Ministry of Trade, Industry and Cooperatives and as of 2017 under the Ministry of Science Technology and Innovation. The Instrumentation Division was founded in 2011 to undertake applied research and development in the area of electronics. The Instrumentation team comprises electrical and computer engineers and the focus has become the design of non-invasive medical technology.

Through institutional-level collaborations with Makerere University's College of Health Sciences, Columbia University in New York, and Oxford BioHorizons Ltd. UK (a company specialising in technology in medicine and biology), the Instrumentation Division has embarked on the design of affordable medical devices for Sub-Saharan Africa and other low-income settings. The design process is inspired by the Stanford Biodesign approach (Yock, et al., 2010). The first two phases of the latter approach, namely identify (uncovering clinical needs and the cycle of care) and invent (brainstorming solutions, rapid prototyping, concept development and intellectual property consideration) have been adopted. The invent phase also captures electronics design, development and testing. The third phase – implement – has been applied partially, in particular, strategy development in terms of clinical validation and exploring sources of funding. Business modelling, regulatory approval, reimbursement, and charting the market potential are still in progress.

Uncovering a priority clinical need

The Instrumentation team decided to focus their efforts based on areas of specialty, availability of resources, and the area with the highest need with few people innovating on the topic. With the team having experience in hardware design, rapid prototyping of electronics and systems design, it was natural to lean towards the design of non-invasive medical technology. This focus was further refined to maternal and child health. Uganda continues to experience health system challenges and poor social determinants of health that have slowed the improvement of women's and children's health. Difficulty in accessing quality services, a shortage of trained and motivated healthcare professionals, and shortages of essential drugs and medicines contribute to high mortality and morbidity rates (WHO, 2011).

The overall goal was to improve significantly healthcare outcomes for a high priority clinical need in a vulnerable population. Design considerations were not limited to functionality, performance and usability, but included infrastructure such as access to reliable power sources, and design for lack of power, which is a common occurrence in rural health facilities.

Having successfully carried out a needs survey across four regions in Uganda (northern, central, eastern and western) and in four major regional referral hospitals, health centres, and the national referral hospital, the team was able to identify numerous clinical needs and gaps related to existing medical equipment. After formulating a list of top priority needs, the team proposed solution ideas. To achieve general consensus on a particular idea, decision criteria and a decision matrix tool were used to enable team members to vote on and rank the most compelling need. The decision matrix was based on the following criteria:

1. *Impact*: what are the numbers involved? How many people's lives would be improved or saved by the proposed intervention?
2. *Feasibility*: Does the team have the requisite skills and partners to implement the proposed design, are there available resources?
3. *Low cost*: What percentage of the raw materials can be accessed locally? Can we make this particular design affordable and accessible for hard-to-reach health facilities?
4. *Priority*: From the perspective of the clinicians, is the need high in priority?

The strategic focus was to innovate for maternal and child health as this group is the most vulnerable in low- and middle-income countries. The severity of the situation was mapped out to determine the best starting point, taking into account the availability of financial resources for implementation. Two methods were used, namely literature reviews and baseline studies; the latter involved several visits to health facilities that included the national referral hospital, Mulago, regional referral hospitals, and health centres in western, eastern and northern Uganda. Studies revealed a persistent challenge in improving child mortality. The leading direct causes of under-five mortality include neonatal conditions (prematurity, asphyxia and infection), malaria, diarrhoea and pneumonia (WHO, 2010). The majority of children presenting for treatment often exhibit advanced disease stage symptoms and usually require immediate intravenous therapy. The FEAST trial estimates that over 10% of children admitted to East African hospitals are in shock due to treatable disease and require immediate infusion therapy (Maitland, et al., 2011). It is important that infusion therapy be administered correctly to ensure timely treatment and safety, especially for sick children, to prevent morbidity and in the worst cases mortality; however, this requires a syringe pump to accurately control intravenous (IV) fluid administration (Graz, et al., 2008). Based on preliminary findings, infusion appeared to be a neglected area with limited interventions.

The WHO recommends syringe pumps as an essential medical device that should be present in all district hospitals for the care of neonates (WHO, 2015). Due to their cost and complexity, commercial syringe pumps are often not readily available in low-resource settings, where the majority of neonatal deaths occur (Lawn, et al., 2006; FDA, 2010). In the absence of syringe or infusion pumps, fluids are delivered with gravity-driven IV drip systems (Slusher, et al., 2012) which neither control nor regulate fluid flow; thus accurate volumes, which are critical for infusion therapy in children, are not guaranteed. Imprecise flow rate control and lack of monitoring with these devices present a risk of over- or under-hydration (Almroth & Latham, 1995).

Existing solutions

To avoid designing an already existing solution and infringing on existing patents, and to better understand why certain design considerations had been avoided in available solutions, an investigation of existing solutions and technologies was carried out. Solutions for both developed and developing countries, their advantages, associated limitations and the reasons why some were not adopted, were systematically examined. The available solutions are described below.

Infusion/elastomeric pumps

Infusion/elastomeric pumps and burettes are commonly used to regulate delivery of IV therapy to paediatric patients in developed nations. Although infusion pumps are accurate and deliver fixed volumes, they are too costly and not appropriate for healthcare settings in many developing countries. Priced over US\$1,000, infusion pumps require routine maintenance, expensive consumables that are not generally available in the developing world, and electrical power that may not be reliable, making them unsuitable for the developing world.

DripAssistTM flow monitor

The DripAssistTM is a device that allows users to monitor gravity fed infusion therapy and respond to an alarm to ensure that the infusion rate remains constant. Although the device does not control the rate of infusion, it provides clear and simple feedback, allowing users to clearly see how their drip tubing set is functioning (Ssekitoleko, et al., 2015). Initially used as a veterinary device, it has been piloted to improve the administration of medications during labour to prevent postpartum haemorrhage, preeclampsia and eclampsia in low-resource settings. The device has been clinically piloted in Haitian clinics on expectant mothers who received oxytocin and magnesium sulfate intravenously (Pedagogy Infusion Online Learning System, 2017).

Acuset IV flow controller

The Acuset IV Flow Controller is a reusable IV flow controller which is intuitive to use even by relatively untrained operators (Medicine Mondiale, 2008). The controller regulates drug delivery by rotation of a dial to the expected setting. However, it neither dynamically adjusts nor maintains the rate of flow at a given/set degree of constriction, resulting in slight variations in flow rate as the drip bag is being emptied owing to external atmospheric conditions and hydrostatic pressure.

Burettes/fluid giving sets

Burettes deliver measured volumes of fluid or medication. They are however impractical for use in low-resource settings because they are single-use, in addition to not being very accurate. Specifications for burettes and fluid giving sets are based on the performance of the drop orifice in delivering a specified volume of fluid (usually within $\pm 10\%$), and not the rate, as this is dependent

on the clinician regulating the appropriate flow rate for the therapy. Research has shown that when manually regulated, fluid delivery flow rate variances of $\pm 20\%$ (error between prescribed and actual flow rates) occur in 80% of intravenous administrations, inclusive of burette administration (Kolko & Intlekofer, 2016). Such flow rate errors escalate to errors in the overall volume delivered to the patient.

Understanding the challenge

The team embarked on field trips to collect primary data and information that would essentially guide the design process for the identified challenge of improving the quality and affordability of infusion. Four major regional referral hospitals – Mbarara, Fortportal, Mbale, Gulu and Soroti – and three health centres – Bukuku, Lamogi, Amuria – were visited during the first two quarters of 2017. The objective of the study was to uncover challenges related to infusion therapy, inadequacies with existing infusion pumps or controllers if available, the reasons why infusion pumps break down, the maintenance regimen, and the desired features of a device that could potentially address these gaps.

The team met and interviewed various stakeholders, including physicians, nurses, patients, carers and biomedical technicians. Interviews were aided by a questionnaire that served as a guiding tool to collect both quantitative and qualitative data. The end goal was to design for the end user based on the data that was collected. In addition to interviews, the team observed clinicians' day to day activities i.e. observing the work flow in an emergency ward and clinicians interacting with medical equipment. The observations uncovered additional challenges that were missed during face-to-face discussions. Access to inventories of medical equipment and discussions with biomedical technicians revealed the reasons why equipment fails.

Data from the maternal and paediatric wards at the eight health facilities revealed the following challenges.

Paediatric ward challenges with infusion

1. Due to a lack of infusion pumps or controllers that are critical for intravenous delivery of IV fluids and drugs, these are currently being manually administered; on average more than 60 infusions are carried out daily.
2. Over- and under-infusion are common due to severe workload challenges; it is difficult to maintain and monitor the prescribed flow rate manually due to the high number of children admitted.
3. Inadequacy of consumables e.g. fluid giving sets and drugs lead to an additional financial burden on the patient who is required to purchase the needed materials.
4. There is a shortage of blood from the blood bank to infuse anaemic children; over 85% of children are anaemic and require blood transfusion.
5. The ward is severely congested due to the overwhelming number of children requiring admission.
6. Severe cases of shock in children are usually referrals from smaller community health centres.

Maternal ward challenges with infusion

1. There is a lack of infusion pumps or controllers that are critical for intravenous delivery of oxytocin or misoprostol; improper infusion of these drugs can cause rupture of the uterus or birth asphyxia for the neonate.
2. Blood transfusion for mothers experiencing postpartum haemorrhage or with ectopic pregnancy is a necessity, however there is a limited supply of blood; a possible solution could be recycling of blood to re-infuse into the mother.

Conceptualisation

In response to the identified need for an infusion device that regulates infusion therapy, the Electronically Controlled Gravity Feed Infusion Set (ECGF) prototype v1.1 has been designed; the ECGF automatically regulates the drop rate for infusion therapies for drugs and fluids and provides the minimum safety features for implementation in a hospital setting. Figure 1 shows the four modules that make up the ECGF device.

Figure 1: Modules of the electronically controlled gravity feed infusion set (ECGF);
 A: Drop rate detector, connects to the infusion set drip chamber and monitors the drop/infusion rate;
 B: Drop rate controller, clamps onto and constricts the infusion tube to regulate the infusion rate;
 C: User Interface, to allow the user to input parameters for the therapy that include infusion bag size, size of the fluid giving set, volume to be infused and infusion time;
 D: Power supply for the ECGF device.

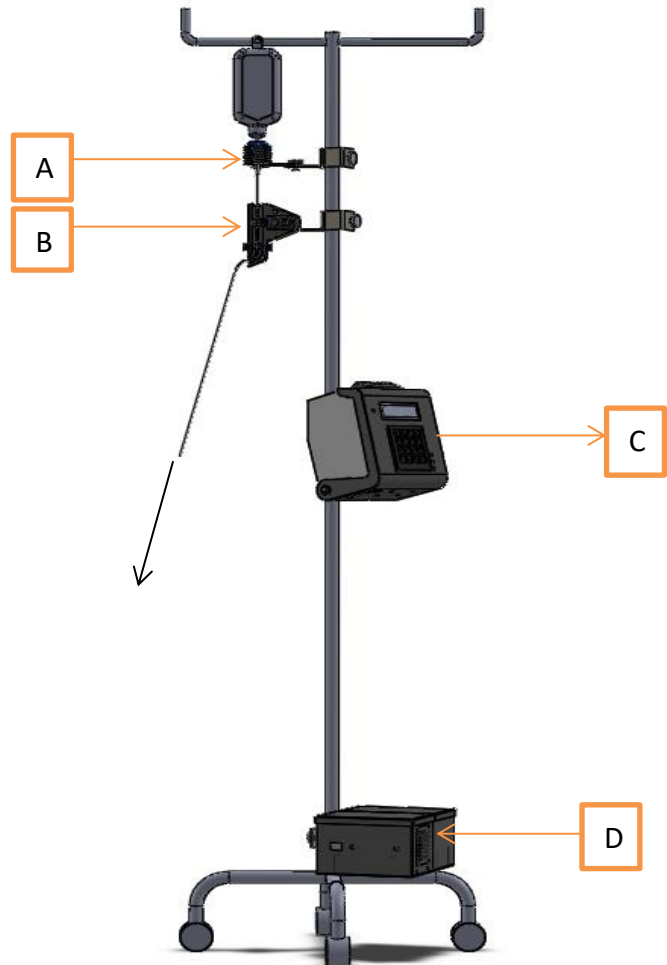

System overview

Micro-processor/logical unit

The logical unit is the heart of the system and it receives input from all the various peripheral units (analog to digital converter, counter, USART, keypad, memory, switches), and algorithmically processes the inputs and transmits instructions to the actuators/output units (Ssekitoleko, et al., 2015).

Drop rate detector module

This module is responsible for the drop rate detection. The module comprises a light source and a photo-cell. Signals from the photo-cell are transmitted to the processing/logical unit.

Drop rate controller module

This module is responsible for effecting the change desired as per instructions from the logical unit resulting from the feedback from the monitoring module. An appropriate constriction of the drip line/tube results in an adjustment/continuance of a drip/flow rate. It also caters for air bubble and occlusion detection.

User interface

The user interface provides the user with vital information and provides alerts indicative of system performance or status as well as allowing for human–machine interaction by way of various input options.

Comparison with infusion pumps on the market

The ECGF is comparable in functionality with some of the infusion pumps on the market in terms of performance and safety features. The ECGF has been tested for flow rates 15–300ml/hr. Further development will refine accuracies for slower and faster flow rates. Clinically most flow rates fall within the tested range. Table 1 compares the ECGF with the Hospira A+ Infusion System.

Table 1: Comparison between the ECGF and the Hospira A+ Infusion System		
Development	Hospira A+ Infusion System	ECGF
Subassemblies	1 part	4 parts
Supply chain complexity	0% local materials	80% local materials
User training	Minimum 2–3 weeks	4 hours (intuitive and easy to use user interface)
Power consumption	High (35VA)	Low (6VA)
Maintenance support	Costly and limited	Affordable and locally available
Battery life	Approx. 6 hours	Approx. 8 hours
Delivery accuracy	± 5 (1–999mL/hr), ± 10 (0.1–0.9mL/hr)	± 1 (15mL/hr – 300mL/hr) for preclinical tests on v1.1 prototype
System alarms	Air-in-line, air-in-line backpriming, low battery, occlusion, turn to run, flow detector, VTBI complete or dose end	Low battery with status LEDs, occlusion, flow detector, VTBI complete or dose end
Added value	None	Solar system can be used for battery charging & hospital lighting
Selling price	~US\$1300–3000	~US\$100

Design and manufacture

The ECGF is an embedded system application designed to perform a specific function. Embedded systems are a combination of computer hardware and software that are programmable with a fixed capacity that includes electrical and mechanical components. These systems are designed for a specific function or for specific functions within a larger system. The design of the ECGF therefore comprises both software and hardware design processes.

AutoCAD software, EAGLE, was used to design the schematics of the ECGF electronic circuits and the layout of the printed circuit boards. Proteus software was used for simulation and debugging of the electronic circuit before preliminary hardware prototyping using breadboards, oscilloscopes and power supply units. During initial prototyping, electronic components were mounted on a breadboard, the microcontroller was programmed to perform specific functions and the circuit output was analysed. Additive manufacturing specifically 3D printing was particularly useful for the intricate parts of the device, in particular variations of specific parts were printed for testing, towards achieving an optimal design. SolidWorks software was used for the casing design of the drop rate detector and the drop rate controller and printed using a 3D printer. The microcontroller was from Microchip Technology Inc.; a PICkit 3 was used for programming and Integrated Development Environment (IDE) software called MPLAB for the firmware. The firmware underwent verification and validation tests to ensure that it performed as specified. The Instrumentation Division complies with the coding standard for critical systems (Doering, 2004).

After the circuits have been verified and validated to function as required, the final stage of the development of the device was the manufacturing process that consisted of etching and milling the printed circuit boards and manufacturing of the casings for the drop rate detector and drop rate controller using a 3D printer. The drip stands were fabricated using mild steel in compliance to standard BS 3619:1976 for mobile infusion stands (British Standards, 1976). Figure 2 shows in-house manufacturing of the ECGF user interface.



Figure 2: In-house manufacturing of the ECGF user interface

Preclinical studies

In order to verify the accuracy of the ECGF prototype v1.1 a test setup was used in compliance to the standard IEC 60601-2-24 for medical electrical equipment (IEC, 1998). The standard contains particular requirements specifically for the safety of infusion pumps and controllers. The ECGF v1.1 is categorized as a drop rate controller, however, the updated standard has a heavy focus on regulation of volume to be infused in addition to the drop rate (IEC, 2012). The next version of the ECGF (v2.0) will include design for regulation of volume to be infused.

The ECGF device is designed to operate in a drop rate scope between 5–100 drops/min which is equivalent to a flow rate of 15–300ml/h, assuming a 20 drops/ml IV giving set. According to the baseline studies conducted in the eight health facilities, this range covers all the required IV infusions for the target group (children under the age of five). The testing parameters for infusion delivery to cover the operating scope of the device are shown in Table 2.

Test case 1 and 2 are compliant with the required infusion rates for accuracy tests mentioned in the standard IEC 60601-2-24 (IEC, 1998). Each delivery rate test was repeated three times.

Table 2: Test cases for infusion accuracy tests

Test case #	Drop rate r [1/min]	Flow rate f [ml/hr]	Infusion time [min]	Infusion volume [ml]
1	5	15	180	45.0
2	20	60	180	180.0
3	50	150	180	450.0
4	75	225	180	675.0
5	100	300	180	900.0

To ensure reliable results, new infusion set tubing, a new cannula needle and a new solution bag were mounted before each test run. During the test period the total drop count N_x and the corresponding total infusion time stamp t_x were collected every 12s via RS-232 serial interface to a separate data assessment computer using RS-232 terminal software.

Test results

Through the calculation of the actual drip rate Q_i from the collected data of all conducted tests, it was possible to plot the start-up graphs for each test case. As an example, Figure 3 shows the progression of the actual drip rate Q_i over the test period T_0 (the first 2 hours) performed with a desired drip rate r of 20 drops/min (test case 2).

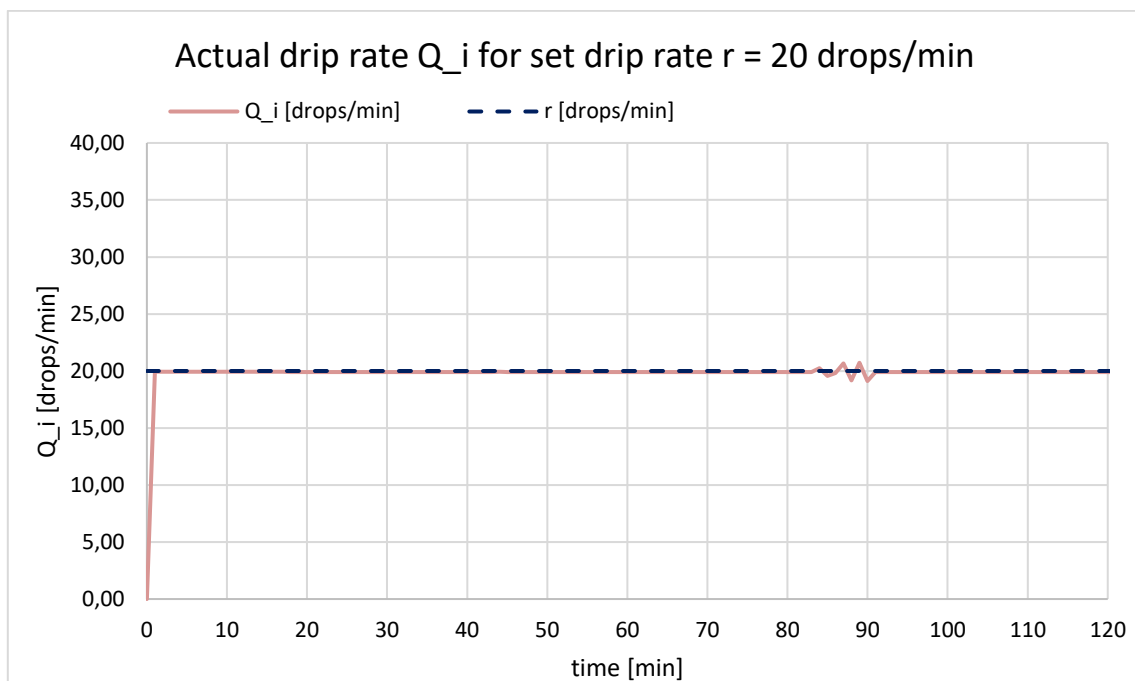

Figure 3: Plotted start-up graph of the actual drip rate Q_i for a set drip rate r of 20 drops/min for test period T_0 of 120 min

All tests conducted with the ECGF prototype v1.1 showed the ability of the ECGF device to deliver fluids with a relatively high degree of accuracy. See Table 3 for an overview of all test results per test case. Neither the overall mean percentage error E_{total} for the entire test period nor the percentage errors A and B for the second and the last hour of the test period respectively show values greater than $\pm 1\%$.

Test Case (TC)	R (drp/min)	Q_total [drp/min]	E_total [%]	Q_T1 [drp/min]	A_T1 [%]	Q_T2 [drp/min]	B_T2 [%]
1	5	4.987	-0.257	4.977	-0.468	4.966	-0.671
2	20	19.931	-0.343	19.917	-0.415	19.918	-0.412
3	50	49.801	-0.398	49.786	-0.428	49.762	-0.477
4	75	74.698	-0.402	74.684	-0.422	74.660	-0.453
5	100	99.585	-0.415	99.566	-0.434	99.555	-0.445

Conclusion

The Instrumentation Division at UIRI has developed the ECGF in response to a demonstrated clinical need to improve the safety and efficiency of delivering intravenous fluids to children. In-house design and development enabled the design team to iteratively test and design the first version of the ECGF device that is acceptable for clinical use. The public health impact of the device will be a contribution to safer and less labour-intensive delivery of drugs to patients by reducing the clinician time involved in manual regulation of the rate of fluid flow. The potential impact will be lives saved, alleviation of the human resource burden, improved usability of an infusion medical device and improved patient care. The Uganda Industrial Research Institute plans to develop a feasible implementation plan to scale up this and other medical device innovations to improve access to quality medical devices and alleviate the shortage of appropriate medical equipment in Uganda and other similar developing country settings.

Acknowledgements

The Instrumentation Division at Uganda Industrial Research Institute, clinical partners at Makerere University College of Health Sciences, School of Medicine, Dr. Sabrina-Bakeera Kitaka, Dr. David Meya, and technical advisors Professor Peter Rolfe, Oxford BioHorizons Ltd. UK and Professor Aaron Kyle, Department of Biomedical Engineering, Columbia University, New York, have made notable contributions to the project. The project is supported by Grand Challenges Canada, the Patient Safety Movement Foundation, CA, USA and the Africa Innovation Foundation (AIF).

References

- Almroth, S. & Latham, M. 1995. Rational home management of diarrhea. *Lancet*. 345(8951):709–711.
- Barry, J. & Pathe, S. 2008. Health challenges in Africa and the way forward. *International Archives of Medicine*. 1:27. DOI: 10.1186/1755-7682-1-27.
- British Standards. 1976. *BS 3619:1976 Specification. mobile infusion stands*. London: British Standards Institution.
- Doering, T. 2004. *MISRA-C:2004: guidelines for the use of the C language in critical systems*. Warwickshire, UK: MIRA Limited.
- FDA. 2010. *White paper: infusion pump improvement initiative*. US Food and Drug Administration. Available: <https://www.fda.gov/medical-devices/infusion-pumps/white-paper-infusion-pump-improvement-initiative> [2019, May 29].
- Graz, B., Dicko, M., Willcox, M.L., Lambert, B., Falquet, J., Forster, M., Giani, S., Diakite, C. et al. 2008. Sublingual sugar for hypoglycaemia in children with severe malaria: a pilot clinical study. *Malaria Journal*. 7:242. DOI: 10.1186/1475-2875-7-242.
- IEC. 1998. *IEC 60601-2-24:1998 Medical electrical equipment – Part 2: Particular requirements for the safety of infusion pumps and controllers*. Geneva: IEC.
- IEC. 2012. *IEC 60601-2-24:2012 Medical Electrical Equipment Part 2b: Particular requirements for the basic safety and essential performance of infusion pumps and controllers*. Geneva: IEC.
- Kolko, B. & Intlekofer, K. 2016. *DripAssist™ Infusion Rate Monitor, Unique Low-Cost Device for Gravity Drip IV Infusion, Commercially Launches in US with a Focus on Nursing and Healthcare Innovation*, Seattle, Washington: Cision PRWEB.
- Lawn, J. et al. 2006. 1 year after the Lancet Neonatal Survival Series: was the call for action heard?. *Lancet*, 367(9521):1541– 1547. DOI: 10.1016/S0140-6736(06)68587-5.
- Maitland, K. et al. 2011. Mortality after Fluid Bolus in African children with severe infection. *New England Journal of Medicine*, 364(26):2483–2495.
- Medicine Mondiale. 2008. *Acuset IV Flow Controller*. Available: <http://www.medicinemoniale.org/PROJECTS/Acuset+IV+Flow+Controller.html>. [2019, May 06].
- OAG. 2015. *Efficiency of operations in regional referral hospitals in Uganda*. Available: <http://www.oag.go.ug/wp-content/uploads/2016/07/Efficiency-of-Operations-of-Regional-Referral-Hospitals.pdf> [2019, May 06].
- Pedagogy Infusion Online Learning System. 2017. *DripAssist – A new, simple tool to enhance the age-old practice of gravity infusion*. Available: <https://www.pedagogyeducation.com/Infusion-Campus/Student-Union/Campus-Blog/March-2017/DripAssist-A-New,-Simple-Tool-to-Enhance-the-Age-O.aspx> [2019, May 06].
- Slusher, T., Vaucher, Y., Zamora, T. & Curtis, B. 2012. Feeding and fluids in the premature and sick newborns in the low- middle income countries. In: *Contemporary Pediatrics*. InTech. Available: <https://www.intechopen.com/books/contemporary-pediatrics/feeding-and-fluids-in-the-premature-and-sick-newborn-in-the-low-middle-income-countries> [2019, May 06].
- Ssekitoleko, S., Niyitanga, P., Ocheng, M., Makobore, P.N., & Rolfe, P. 2015. *Design of a low-cost electronically controlled gravity-feed infusion set. Conference Proceeding: AFRICON*. Addis Ababa, Ethiopia. 989–994.
- WHO. 2010. *Maternal, newborn and child survival*. Geneva: World Health Organization.

WHO. 2011. *Maternal and child health: Uganda*. Available:

<https://www.who.int/pmnch/media/membernews/2011/ugandabackgroundpaper.pdf> [2019, May 06].

WHO. 2015. *Intragency list of medical devices for essential interventions for reproductive, maternal, newborn and child health*. Available:

https://www.who.int/medical_devices/publications/interagency_med_dev_list/en/ [2019, May 06].

Yock, P., Zenios, S. & Brinton, T. 2010. *Biodesign: The process of innovating medical technologies*.

Cambridge: Cambridge University Press.

Chapter 16

A Prototype Metabolic Cage for Rats and Mice for Biomedical Research in Nigeria

O.A. Adejumobi, C.J. Diji, M.K.C. Sridhar, A.O. Coker, N. Idusuyi,
C.G. Achi, O.O. Omotosho, T.O. Omobowale & A.O. Olorunnisola

Introduction

Animal experimentation is a regular feature of biomedical research and training. The common laboratory animals used include rats, mice, guinea pigs, rabbits, frogs, cats, dogs, monkeys, pigeons and hamsters (Badyal & Desai, 2014). These animals are typically used for research relating to drug discovery, the endocrine system, cosmetic testing (mutagenicity, phytotoxicity, genotoxicity, allergy, etc.) and toxicology. Ethics and animal use regulations require humane handling and reduction of pain of experimental animals (Flecknell, 2002).

For biomedical research requiring the collection of urine and faecal samples from laboratory animals, samples should not be contaminated with feed and water. Such research may involve analysis of metabolites and toxic products, or assessment of the state of vital organs by urinalysis. Urine and faecal analyses enable a researcher to know the health or physiological status of the animal (Kurien et al., 2004). There is therefore a need to find means of collecting uncontaminated urine and faecal samples, and metabolic cages provide such a means. These cages allow for separate collection of urine and faeces for analysis. Housing laboratory animals in metabolic cages enhances studies on the pharmacological, pharmacodynamic and toxicological effects of new substances, drugs and feed. Veterinary clinicians and biomedical researchers, therefore, often require metabolic cages for research on small and large laboratory animals.

Metabolic cages are commercially available and are produced using different materials, including plastic and polycarbonated stainless steel (Kurien et al., 2004). A general requirement of such a cage is that it must have a compartment with a wire mesh floor to allow urine and faeces to be collected in the funnel chamber below. The faeces roll down the side of the funnel into a collecting chamber or mesh. The feed chamber is usually located outside the cage and constructed in such a way as not to allow feed to get into the cage or resting chamber and thereby contaminate urine and faeces. The water bottle is calibrated and located outside the cage; it is usually provided with a spillage collecting funnel linked to a tube to prevent contamination of urine and faeces in the main chamber.

A major constraint in Nigeria is the fact that these laboratory cages are not readily available because of their cost. Most clinicians, researchers and institutions that require the cages import them, and a unit typically costs more than US\$500. A number of local researchers have, therefore, devised

different methods for the collection of urine and faecal samples. Some have used crude wire mesh housing placed on bowls, while others have used wooden boxes with wire mesh and net to collect samples. These methods, however, may impose a lot of stress on laboratory animals, thereby altering experimental results (Eriksson et al., 2004).

The aim of this project was to design and fabricate a safe, compact and affordable metabolic cage for small animal experimentation especially for rats and mice, that would meet the requirements of end-users including biomedical researchers.

Needs assessment

A needs assessment indicated that a metabolic cage with a unit cost of less than US\$100 would be acceptable to the end users, including nutritionists, pharmacologists, physiologists, biochemists and research students. The cage should be constructed to prevent trauma to the laboratory animal.

Design parameters

The design parameters for the cage as specified by the users are outlined below.

- It should be able to adequately separate urine and faecal samples and prevent contamination from water and feed.
- It should be made of materials that are resistant to corrosion, easy to clean and can be autoclaved.
- The component parts should be easy to detach and assemble for ease of cleaning and disinfection.
- Provision should be made for adequate ventilation in the cage.

Prototype

The component parts of the prototype metabolic cage that was developed are presented in Figures 1 to 6. Stainless steel was used in the construction of the cage stand, housing and floor. This is because it is readily available in Nigeria, relatively inexpensive and resistant to corrosion from urine and water soiling. Provision was made for the collection and separation of urine and faecal samples for analysis, as well as for water spillage and feed contamination control. Urine collection is done by a calibrated tube, which is placed beneath the cage and allows for the measurement of urine volume. Provision was also made for the measurement of feed consumption and quantity of water supplied or consumed. The quantity of feed supplied can be compared with what remains in order to obtain the daily consumption. The quantity of water consumed daily can be determined by subtracting the quantity of water left in the water bottle from the quantity supplied. Safety standards were followed for the housing compartment, these include the choice of non-corrosive, non-toxic stainless steel, medium gauge wire mesh of 1–2mm diameter to prevent injury to the feet of the

animals, and welding and folding of the joints and edges to prevent injury to the animals. The wire mesh will provide adequate ventilation. Feeding, watering, and spillage outlet facilities were provided to prevent cross-contamination. The components of the cage are detachable, and therefore easy to clean and replace when necessary.

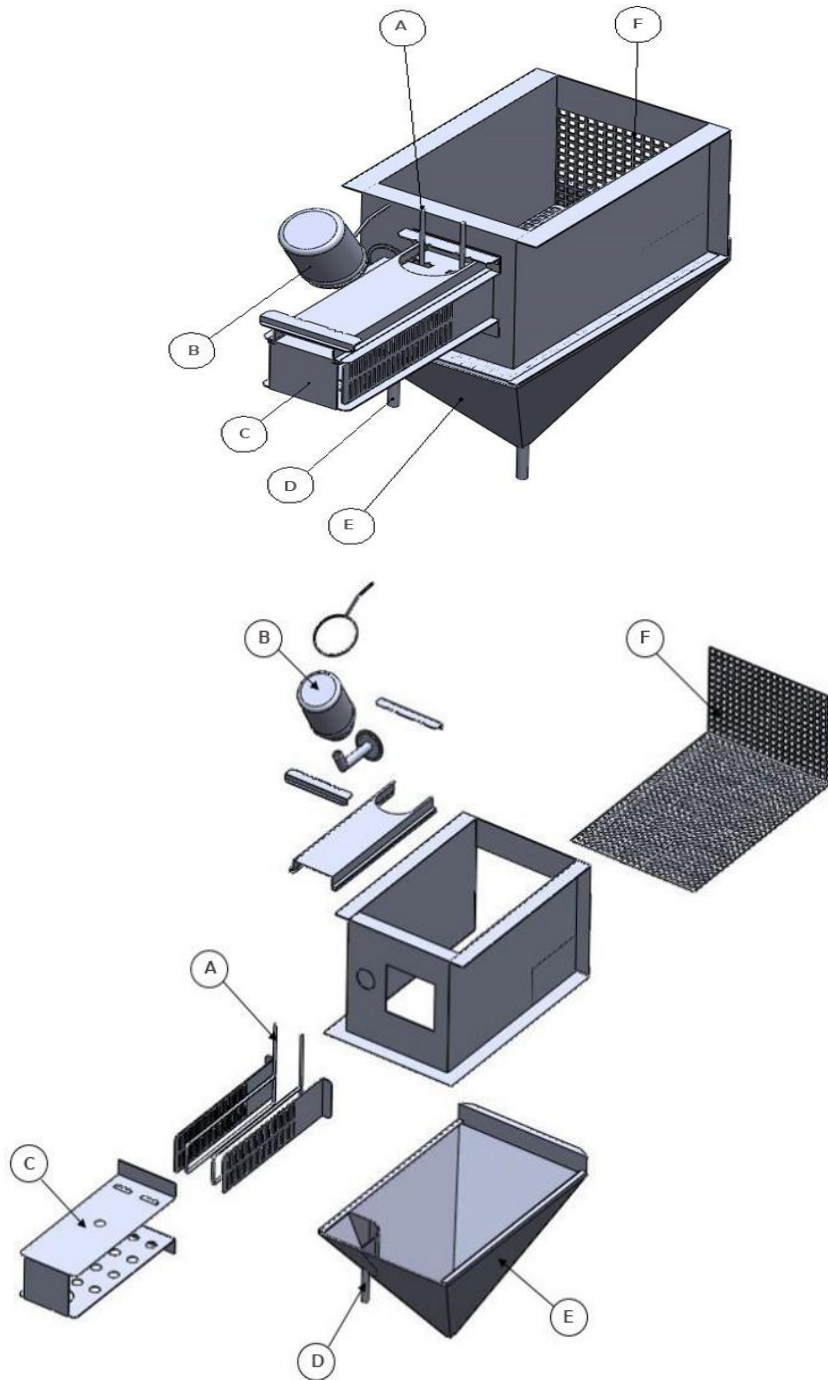

Figure 1: Views of the prototype metabolic cage. A: adjuster (for adjusting the resting compartment to suit the size of animal), B: water bottle, C: resting compartment, D: water drainage pipe, E: base hopper (funnel for collecting faeces), F: wire mesh.

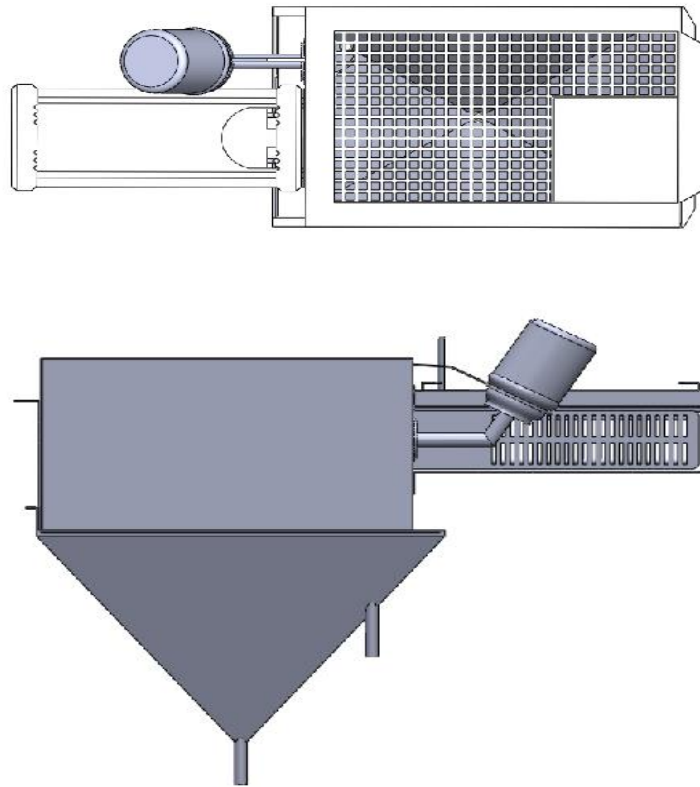

Figure 2: Top view (top) and side view (bottom) of prototype metabolic cage.

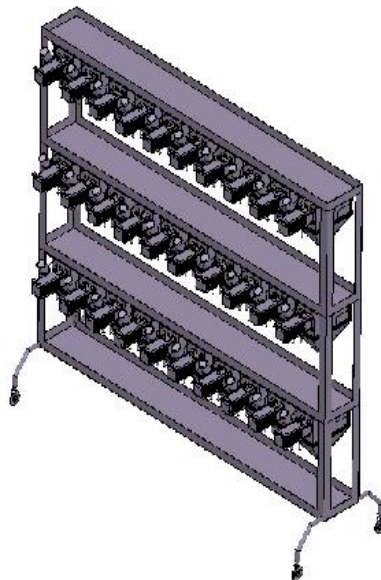

Figure 3: 30-unit metabolic cage stand with cages. Cages are connected to a rack attached to the bottom of a horizontal plate. The horizontal plates serve as cover for the cages and as base on which urine collecting jars are arranged in alignment with the urine collecting outlets of the cages above them. The stand has wheels for mobility.



Figure 4: Top, left: side view of the metabolic cage with open slits (blue arrow) on the resting compartment for ventilation; adjustable side plates (green arrow) to suit rodent size; and playing, feeding and drinking unit (black arrow), where feeding and drinking accessories are fixed.

Top, right: upper part of cage, which is attached to cage stand; wire mesh (red arrow) on which the rodents stand; and resting compartment (blue arrow).

Bottom: base of cage with resting compartment (black arrow); and wire mesh (blue arrow) on floor of cage.

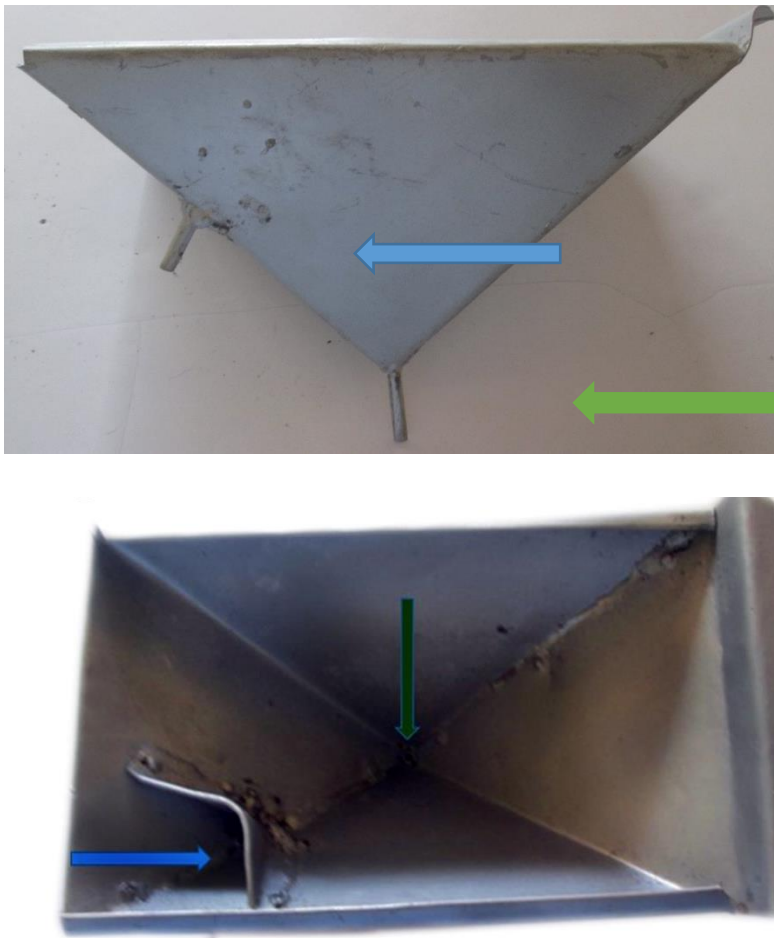

Figure 5: Top: side view of base hopper, spilled water outlet pipe (blue arrow) and urine outlet pipe (green arrow).

Bottom: Inside view of the base hopper with openings for spilled water outlet (blue arrow), and urine outlet (green arrow). The urine outlet prevents urine contamination by water drops from the drinking bottle while the animals drink from it.



Figure 6: Rodent drinking bottle with water spillage control nipple.

Cost Analysis

The total cost for the manufacturing of a unit of the prototype metabolic cage for rats and mice was US\$80, which met the requirement of the end users. The unit cost is expected to go down with increased production.

Conclusion

A prototype of a compact, detachable and affordable metabolic cage for small animal experimentation has been developed for biomedical research in Nigeria. The cage meets end-user requirements in terms of cost, functionality and safety. Larger-scale production of the cage is expected to bring down its unit cost and facilitate medical and biomedical research in Nigeria.

Acknowledgement

The authors are grateful for a seed award for the study under a grant from the Fogarty International Center of the National Institutes of Health (D43TW009374), and to Ray Rabtech Engineering Workshop for its manufacturing contributions.

References

- Badyal, D. & Desai, C. 2014. Animal use in pharmacology education: the changing scenario. *Indian Journal of Pharmacology*. 46(3):257–265.
- Eriksson, E., Royo, F., Lyberg, K., Carlsson, H.E. & Hau, J. 2004. Effect of metabolic cage housing on immunoglobulin A and corticosterone excretion in faeces and urine of young male rats. *Experimental Physiology*. 89(4): 427–433. DOI: 10.1113/expphysiol.2004.027656.
- Flecknell, P. 2002. Replacement, reduction and refinement. *ALTEX*. 19(2): 73–8.
- Kurien, B.T., Everds, N.E. & Scofield, R.H. 2004. Experimental animal urine collection: a review. *Laboratory Animals*. 38: 333-361.

Part 4

Ethical, Legal and Regulatory Considerations for Biomedical Engineers

Chapter 17

Biomedical Engineering Ethics

O. Ewaleifoh, O. Adeleye, A.O. Balogun, S.O. Adetona,
K.O. Soetan, S.O. Adeosun & A.A. Osuntoki

Introduction

Biomedical engineering remains one of the most dynamic disciplines in the world, standing at the intersection of engineering innovation and health care delivery. The growth of biomedical engineering can be seen in its increasing scope and pervasive application; from cellular and tissue engineering to biomaterial design for heart and neural implants. While exciting, this rapid growth of biomedical engineering raises several critical ethical questions that must be understood and resolved.

Biomedical engineering is unique as an engineering specialty, in that it is a synthesis of engineering principles and medical practice. The unique professional identity of biomedical engineering necessitates a set of ethical frameworks that are sensitive to both medical and engineering standards. Thus, whereas engineering ethics is narrowly focused on 'safety' and medical ethics on 'patient care' (Burgess et al., 2013), biomedical engineering ethics occupies the intersection of safety and patient care, beginning at scientific experimentation and design, and extending through medical practice and administration. Understanding the history of engineering ethics and biomedical ethics is thus essential to understanding the evolution and future of modern biomedical engineering ethics.

The goal of this chapter is to stimulate awareness of the need for ethical thinking in biomedical engineering, to trace the origins and essential fundamentals of engineering and biomedical ethics, and finally to highlight some considerations for Africa, where biomedical engineering is still in its infancy and regulatory policies remain limited.

Engineering ethics

While the origins of medical ethics can be traced to the centuries old Hippocratic Oath, the origins of engineering ethics are more recent and can be traced to the 2nd of September 1914 when the American Society for Civil Engineers (ASCE) defined six principles of engineering ethics focused primarily on an engineer's business obligations to his or her clients and employers. While progressive, it is noteworthy that these early engineering ethical canons made no mention of the engineer's responsibility to his or her community or the public at large. However, in response to the evolving social landscape and expectations in the 1960s and 70s as well as the United Nations sustainable development campaign, these canons were retooled to reflect a more socially

DOI: <http://dx.doi.org/10.15641/0-7992-2544-0>

<https://openbooks.uct.ac.za/bmeafrica>

responsible engineering ethos focused heavily on the engineer's role in the world and public safety, as reflected below (ASCE, 2011):

1. *Engineers shall hold paramount the safety, health and welfare of the public and shall strive to comply with the principles of sustainable development in the performance of their professional duties.*
2. *Engineers shall perform services only in areas of their competence.*
3. *Engineers shall issue public statements only in an objective and truthful manner.*
4. *Engineers shall act in professional matters for each employer or client as faithful agents or trustees, and shall avoid conflicts of interest.*
5. *Engineers shall build their professional reputation on the merit of their services and shall not compete unfairly with others.*
6. *Engineers shall act in such a manner as to uphold and enhance the honour, integrity, and dignity of the engineering profession and shall act with zero-tolerance for bribery, fraud, and corruption.*
7. *Engineers shall continue their professional development throughout their careers, and shall provide opportunities for the professional development of those engineers under their supervision.*
8. *Engineers shall, in all matters related to their profession, treat all persons fairly and encourage equitable participation without regard to gender or gender identity, race, national origin, ethnicity, religion, age, sexual orientation, disability, political affiliation, or family, marital, or economic status.*

While this most recent iteration of the engineering code of ethics as articulated by the ASCE is an improvement over earlier versions, it still represents an unacceptably low ethical threshold for biomedical engineering (Monzon & Monzon-Wyngaard, 2009). For whereas traditional engineering focuses on the design, applications and manipulation of inert materials and inanimate objects, biomedical engineering has a broader scope that includes biological materials and human subjects – necessitating a higher ethical standard. Even more progressive than the ASCE's 2011 canon is the National Society of Professional Engineers (NSPE) code of ethics which advocates expansive socially responsible engineering ethics. Still, the more progressive engineering ethics code of the NSPE fails to meet the stringent ethical standards of medical practice that are expected of the biomedical engineer.

Medical ethics

The content and structure of modern biomedical ethics has been shaped largely by contemporary forces such as legal and social events. Thus, despite the fact that the central ethos of the Hippocratic Oath 'first do no harm' had been articulated centuries earlier in medicine, biomedical research remained largely unregulated until the 1970s. This unregulated medical research and practice resulted in wonderful medical advancements, but also led to grotesque human experimentation

that would most certainly be considered criminal today. Scientists freely experimented with potential new treatments on their patients, sometimes with fatal or groundbreaking consequences.

In 1789 a country physician and surgeon from Gloucestershire England named Edward Jenner followed the anecdotal observation of a local milkmaid that “she could not get the small pox because she had already had the cowpox”, and injected his young son with pig pox producing an immune reaction against small pox (Burns, 2003). Following up on this observation, in 1796 Jenner inoculated James Phipps, an eight-year-old boy and the son of Edward Jenner's gardener, with pus obtained from cowpox blisters from the hand of a milkmaid who had caught cowpox from a cow (Williams, 1959). This dramatic act resulted in inoculation against small pox and introduced the golden age of vaccination that we still enjoy today. These invaluable studies by Edward Jenner saved millions of lives and pushed science forward. However by contemporary ethical standards, studies such as these are unacceptable as they violate several fundamental ethical principles as will be discussed below.

Unregulated biomedical experimentation such as Edward Jenner's cowpox inoculation was widespread until 1914, when the US Food and Drug Administration (FDA), founded in 1906, began instituting policies to limit the sale of some narcotics. Still, in the face of limited empirical evidence and hostile resistance from business interests, the efficacy and scope of the FDA in setting ethical standards for medical practice remained severely limited for decades, with detrimental consequences.

The Tuskegee syphilis experiment of the 1930s remains a classic case study of unregulated medical experimentation. On July 26, 1972 the Associated Press broke the story that for over 40 years, the US Public Health Services had maintained a study of untreated black males infected with syphilis, and the study was still ongoing (Howell, 2017). The world reacted with outrage and horror, wondering how this could have happened and for so long. However, in 1932 when the study was initiated, conversations on medical ethics had hardly begun. The demand for a syphilis test had grown, driven by laws requiring syphilis testing for marriage certificates, registering newborns, military recruitment, industrial physical examinations, and admissions to hospitals (Roy, 1995). To better understand the disease etiology and develop more accurate tests, human subjects were needed for both clinical observation and antibody development. The Tuskegee study was initiated with the specific objective of better understanding the natural life cycle of syphilis and to develop diagnostic tools and treatments to manage the disease (Roy, 1995; Howell, 2017).

Starting in 1932, 600 black men were unwittingly recruited and misinformed about procedures to be performed as part of the syphilis study. Over the next 40 years, clinical data and biological samples were collected from these research subjects both to understand the natural course of syphilis and to develop new diagnostic tools for the detection of the disease. It is noteworthy that while unethical and immoral, the Tuskegee study was not illegal at that time, as the National Venereal Disease Control Act of 1938 had expanded the scope of the state to conduct human

research (Roy, 1995). In response to a class action law suit in 1974, 70 surviving members of the Tuskegee syphilis human experiment received settlements; for most of the original study cohort however, this was too little too late (Howell, 2017).

Studies like Tuskegee were widespread during this era, not just in the United States but around the world. As the Tuskegee syphilis study unfolded in Alabama, Nazi scientists also experimented with war prisoners in Germany and occupied territories across Europe during World War II (Park & Grayson, 2008). After the war, these human medical experimentations were ruled as crimes against humanity and perpetrators (mostly research physicians) were convicted in the Nuremberg trials. In the collective determination to protect future human subjects from criminal human experimentation, a 10-point document entitled the Nuremberg Code, was articulated by the tribunal to guide future experiments with human subjects (Shuster, 1997; Park and Grayson, 2008). Whereas the Hippocratic Oath passively encouraged physicians to work in the interest of the patient, this new Nuremberg Code asserted that the consent of the patient is paramount, introducing a key pillar of modern biomedical ethics – informed consent. The Nuremberg Code thus provided the first explicit articulation of criteria that must be fulfilled before human experimentation can proceed (Shuster, 1997):

1. *The voluntary consent of the human subject is absolutely essential.*
2. *The experiment should be such as to yield fruitful results for the good of society, unprocurable by other methods or means of study, and not random and unnecessary in nature.*
3. *The experiment should be so designed and based on the results of animal experimentation and knowledge of the natural history of the disease or other problem under study that the anticipated results will justify the performance of the experiment.*
4. *The experiment should be so conducted as to avoid all unnecessary physical and mental suffering and injury.*
5. *No experiment should be conducted where there is an a priori reason to believe that death or disabling injury will occur; except, perhaps, in those experiments where the experimental physicians also serve as subjects.*
6. *The degree of risk to be taken should never exceed that determined by the humanitarian importance of the problem to be solved by the experiment.*
7. *Proper preparations should be made and adequate facilities provided to protect the experimental subject against even remote possibilities of injury, disability, or death.*
8. *The experiment should be conducted only by scientifically qualified persons. The highest degree of skill and care should be required through all stages of the experiment of those who conduct or engage in the experiment.*
9. *During the course of the experiment the human subject should be at liberty to bring the experiment to an end if he has reached the physical or mental state where continuation of the experiment seems to him to be impossible.*

A human subject, in modern research language, is a living individual from whom a researcher conducting a study obtains data, samples or other personal information through intervention or interaction with the human. Interventions could refer to physical contact for data collection and alteration of the subject or their environment for possible reaction. Interaction could mean formal or informal discussion between researcher and participant (Howell & Obado-Joel, 2016).

Although the Nuremberg Code was developed in response to Nazi atrocities, and subsequently proved invaluable to modern medical ethics, it was largely ignored for a few decades after its articulation until it was revived and expanded as the Declaration of Helsinki by the World Medical Organization in 1964 (Shuster, 1997; Park & Grayson, 2008). The Helsinki declaration is an internationally accepted guide for the conduct of ethical medical research. Similar to the Nuremberg Code from which it evolved, the declaration of Helsinki includes respect for individuals, their right to self-determination and the right to make informed decisions. Thus when a research participant is incompetent, physically or mentally incapable of explicitly giving consent, or is underage, abundant allowance should be provided for surrogate consent to be obtained from an individual authorized to act in the subject's best interest.

Unlike the Nuremberg Code which was relatively abstract and philosophical, the Helsinki Declaration was more concrete and specifically addresses clinical research, providing detailed prescriptive steps for the medical community to regulate itself. Beyond its specific prescriptions for ethical medical research, the Helsinki declaration is 'active' and continues to undergo revisions as new ethical challenges emerge. The current edition of the Helsinki declaration from 2013 serves as the basis of most Institutional Ethics Review Boards, and contains both general principles like the Nuremberg Code as well as specific prescriptions such as the ethical use of placebo and the need for local institutional review boards (Shuster, 1997; WMA, 2013).

Informed consent

At the heart of modern biomedical ethics is informed consent, a concept introduced in the Nuremberg Code and contained in the Declaration of Helsinki. Despite the growing interest and popularity of informed consent as a principle of biomedical ethics, the question – what is informed consent – remains particularly complex for both practical and theoretical reasons. Does simply obtaining a participant's signature alone guarantee informed consent? What is the standard required for consent to be considered informed? This question is important for practical reasons because if we use overly loose criteria such as a signed consent form, informed consent becomes too easy to obtain and loses its moral significance. On the other hand if we use overly demanding criteria for informed consent such as complete understanding and full disclosure, informed consent becomes

almost impossible to obtain. To resolve this dilemma local institutional policies and rules, governed by institutional ethics review boards, set local standards of consent (Howell, 2017).

The challenge of vulnerable populations in biomedical research

One major contribution of the Declaration of Helsinki was the discussion of how to treat vulnerable populations during biomedical research and clinical practice. Vulnerable populations can be broadly considered as subjects or participants not sufficiently informed or able to make self-protective decisions or actions and thus likely to be misused by coercion or ignorance in the course of biomedical research. Vulnerable populations include but are not limited to children, the elderly, the mentally disabled, prisoners, the infirm, the uneducated and the poor (Burns, 2003; Park & Grayson, 2008). Although pervasive, the ethical treatment of the vulnerable has not always been a priority.

It is worth noting that efforts to prevent the exploitation of vulnerable populations also present a major practical dilemma. For instance, restrictions on research on children have resulted in a dramatic under-representation of children in most clinical trials. A recent estimate suggests that as much as 80% of medicines prescribed by pediatricians have not been systematically studied in pediatric populations for dosage, efficacy and risk because of the limited clinical studies in pediatric populations – sometimes resulting in fatal consequences (Fost, 2005; Park & Grayson, 2008).

Privacy and confidentiality

The researcher must respect and maintain the privacy of human subjects and the confidentiality of their information or data. The need for privacy and confidentiality is among greatest challenges of biomedical research. For many research participants, the loss of privacy can have significant consequences including loss of career, insurance, job, or family, as well as stigma. Beyond protecting the privacy of research subjects, maintaining privacy and confidentiality helps maintain research integrity. Consequently every possible measure must be taken to protect the confidentiality and privacy of every research subject. This means no sensitive information on research subjects must be revealed outside the confines of a research study and when such information is shared, this must be done using the ‘need-to-know’ principle, meaning each member of the research team should only know the identity of participants when absolutely necessary to support their role in carrying out the study (Howell & Obado-Joel, 2016). Beyond applying the ‘need-to-know’ principle, additional measures such as anonymizing participant data, data encryption, using passwords, and safe storage, must be strictly enforced. In addition, certain regions and institutions have more specific privacy rules that provide specific security provisions for safeguarding medical information. In these

cases, it is the duty of the ethical researcher to be both thoroughly familiar with such local privacy rules and to implement them as the loss of participant privacy and confidentiality can have fatal consequences.

Research on animals

Significant successes and breakthroughs in health care delivery have been made possible by scientific research using animals, for example the treatment of diabetes and leukaemia, and heart transplants. Animals that have been used include mice, rats, guinea-pigs, hamsters, rabbits, cats, dogs, ferrets, equids, pigs, goats, sheep, cattle, primates, birds, reptiles, amphibians, and fish-rats, guinea pigs, sheep, frogs, dogs, cats, and primates (CBRA, 2018).

Risks and uncertainty in the results of administering untested and unproven treatments on human subjects has necessitated the use of animals in research studies. However, with the use of research animals, harm to the animals must be minimised while maximising the benefits to healthcare. With these principles in mind, research on animal subjects is governed by institutional ethics review boards, in a similar manner as for research on human subjects. The study protocol must ensure that the number of animals used is minimised and if possible, appropriate alternatives should be used (e.g. computer models, tissue and cell cultures). Animal models are used in medical research because of the biological resemblance of animals to humans. Because research animals have shorter a life span than humans, studies can be done across their life span and across generations; in addition their environment (diet, temperature, lighting) can be controlled more easily than with humans (Bateson et al., 2004). Animal models give valuable insight into human biological processes and provide effective experimental flexibility and control that are difficult to obtain in humans.

However, these advantages have not been without resistance as those against the use of animals in research have stated that using animals for humans are inappropriate, citing the differences between humans and animals. Reference is made to the case of the limb defects observed in children of women who took the drug thalidomide during pregnancy, the damaging effects of which were not predicted in animal studies. More recently, it has been pointed out that the use of animals in research contributes to the high failure rate of drug trials as drugs that work in animals might simply not work in humans, and in addition, several human diseases and mutations simply cannot be studied in animals due to interspecies differences (Akhtar, 2015).

Still, the use of animal models for research in place of human subjects has been immensely beneficial to both humans and animals (CBRA, 2018). Medicines and vaccines developed for humans are now used to treat animals, for example vaccines for rabies and distemper in dogs and cats, feline leukaemia, infectious hepatitis virus, tetanus, and heartworm. Other benefits include the preservation of nearly extinct species of the California condor and the tamarins of Brazil, owing to new reproductive techniques.

In the face of immense benefits derived from animal research, the three R's are proposed for ethical animal research: replacement, reduction and refinement (Flecknell, 2002). According to these widely accepted standards, ethical animal research must constantly seek replacement alternatives for animals. For instance, the studies should where possible be performed in a different system such as induced pluripotent stem cells instead of animals. If animals must be used, a reduction approach must be considered, namely to use the lowest number of animals to answer the research question. Finally the ethical animal researcher must seek ways to refine the protocol to ensure the least amount of pain and harm to each animal during the study. The ethical researcher must find new ways to adopt the three R's during research with animals.

Ethical principles in the communication of research

Following the successful conduct of research, the next important task of the scientist is to communicate their work effectively and accurately. This responsibility of communicating scientific information with integrity presents new ethical challenges for the researcher. Specifically, ethical scientific communication must avoid plagiarism, fabrication and falsification (Kaiser, 2014). Fabrication has been defined as recording or reporting data or results that have been made up. Falsification entails the manipulation of research materials, equipment, or processes, or altering or omitting data or results, resulting in inaccurate representation of the research in the research records. Plagiarism is the appropriation of the ideas, methods, results or words or others without giving due credit. Since integrity and truth are the currency of science, plagiarism, fabrication and falsification are regarded as egregious scientific communication misconduct and can have significant personal and professional consequences.

A case of biomedical engineering ethics failure

The preceding sections introduced the concepts of engineering ethics and biomedical ethics. The long-term goal of this chapter is stimulate contemplation on how best to navigate complex ethical issues. The quintessential biomedical engineering ethics case below, on the failure of the Björk-Shiley heart valve, provides material for such contemplation. The description below is adapted from (Blot et al., 2005; Monzon & Monzon-Wyngaard, 2009).

Heart failure remains a leading cause of death in many countries around the world. Dysfunction in the valves leading into and out of the heart is a major contributor to heart failures. In 1976 the Björk-Shiley convexo-concave prosthetic heart valve (also known as BSCC) was developed and introduced to the global market to provide effective relief for patients with diseased native valves. After its adoption in 1978 the BSCC heart valve became the most popular prosthetic valve for over decade. Shortly after introduction to the market however, fractures of the outlet struts of the BSCC valve, resulting in functional anomalies and often death, began to be reported. While the obvious biomedical engineering objective was to create a reliable implantable device that opened-closed in patients several thousand times a day for years, internal investigations later revealed the BSCC

valves were known by the manufacturers to be substandard with poor welding and quality control. Furthermore, during clinical trials, the valve was reported to show material fatigue leading to weld fractures. The manufacturer altered its welding and quality control procedures, but the faulty BSCC valves were not withdrawn from the market, nor were patients informed of eventual failures. Complicating matters further, the FDA, responsible for biomedical regulation, delayed recommending removal of the valve from the market, which led to more disastrous outcomes. Pfizer, the parent company of the manufacturer, reached a settlement with affected patients in 1992, which included patient compensation and funds set aside for research to identify recipients of heart valves at risk of fracture. By December 2003, outlet strut fractures had been reported in 633 BSCC valves (0.7% of 86 000 valves implanted), often with fatal outcomes.

A more recent study reported that there are still over 7,000 patients worldwide wearing the BSCC heart valve, living with the knowledge of its questionable structural integrity and the possibility of its collapse at any time with fatal consequences (Batts, 2014).

The challenge of biomedical engineering ethics in Africa

We have highlighted several fundamental principles and challenges of biomedical ethics. It is worth noting that while universal, each of these principles and challenges must be adapted to local realities and customs. In Africa, each of the principles and challenges discussed above may assume a richer and more complex role depending on local customs, religions and social structure. Still the principles remain the same. In this spirit, it is the duty of the ethical biomedical engineer to find new ways to adapt these universal principles to local realities. For instance, to truly obtain informed consent when working in a remote community with limited English language, might require translating informed consent forms to local dialects, so as to ensure that local research participants understand what they are participating in, no assumptions can be made. Furthermore, the need to adapt ethical principles such as privacy and confidentiality to local realities is even greater in certain countries, where medical information is stigmatised, and where the revelation of a research participant's personal information such as HIV status or sexual orientation might have severe personal, even fatal, consequences. In this context biomedical engineering ethics requires an understanding of the general ethical principles of participant privacy and confidentiality as well as an understanding of local laws and participant risks.

Conclusion

Modern science is neither pure nor infallible, but a continuous struggle towards clarity; a struggle against imperfect methodology as well as psychological, technical and social limitations (Kaiser, 2014). In light of these limitations the task of the biomedical engineer, like that of any scientist, is to struggle honestly and ethically. An early commitment to ethical biomedical research and clinical practice can provide an excellent long-term guide to help navigate the rapidly evolving field of biomedical engineering. The consequences of poor biomedical engineering ethics can be

devastating and long lasting, both for individuals and for communities. The public faith in science can easily be shattered if behaviour emerges suggesting scientific misconduct.

While this chapter has highlighted a few major topics in ethics, a sea of questions remains and new questions continue to emerge daily. A few of these questions worth contemplating include: Privacy: how do we maintain patient privacy in the era of big data? Patent rights: who owns the rights to advancements derived from patient specimens? Regulations: what happens when local regulations, laws and policies lag behind biomedical engineering innovations? Augmentation, eugenics and life extension: as advances in biomedical engineering continue to improve our capacity to implant new devices, edit undesirable genes and prolong life artificially, should there be a limit to these advances?

Modern biomedical engineering ethics is continuously evolving, driven by forces of local law, culture, evolving social consciousness, and morality. Ethical questions in biomedical research can be difficult as revealed by the Tuskegee syphilis study, where the study was both legal and unethical. This dilemma makes it imperative for the ethical biomedical engineer to uphold a standard higher than local laws but grounded in ethical principles. The pioneers of biomedical engineering in Africa, for whom this book is intended, will have the opportunity not just to contribute to the science of biomedical engineering, but also to shape its public image and ethical landscape. A commitment to the principles of ethics discussed here should provide a stable first step towards a culture of ethical biomedical engineering.

References

- Akhtar, A. 2015. The flaws and human harms of animal experimentation. *Cambridge Quarterly of Healthcare Ethics*. 24(4):407–419. DOI:10.1017/S0963180115000079.
- ASCE. 2011. *Ethics codes collections*. CSEP Library: American Society of Civil Engineers. Available: <http://ethics.iit.edu/ecodes/node/4093> [2019, May 06].
- Bateson, P., Biggs, P., Cuthbert, A., Cuthill, I., Festing, M., Keverne, E.B., King, S., Page, C. et al. 2004. *The use of non-human animals in research: a guide for scientists*. London: The Royal Society. Science Advice Section.
- Batts, G. 2014. The Björk–Shiley Convexo–Concave heart valve experience from the perspective of the supervisory panel. *American Journal of Cardiology*. 113(12):2088–2089. DOI: 10.1016/j.amjcard.2014.03.031.
- Blot, W.J., Ibrahim, M.A., Ivey, T.D., Acheson, D.E., Brookmeyer, R., Weyman, A., Defauw, J., Smith, J.K. et al. 2005. Twenty-five-year experience with the Bjork–Shiley convexoconcave heart valve: a continuing clinical concern. *Circulation*. 111 (21):2850–2857. DOI:10.1161/circulationaha.104.511659.
- Burgess, R.A., Davis, M., Dyrud, M.A., Herkert, J.R., Hollander, R.D., Newton, L., Pritchard, M.S. & Vesilind, P.A. 2013. Engineering ethics: looking back, looking forward. *Science and Engineering Ethics*. 19(3):1395–1404. DOI:10.1007/s11948-012-9374-7.
- Burns, J.P. 2003. Research in children. *Critical Care Medicine*. 31(3 Suppl):S131-136. DOI: 10.1097/01.ccm.0000054905.39382.58.

- CBRA. 2018. Why are animals necessary in biomedical research? Available: <https://cabiomed.org/CSBR/pdf/fs-whynecessary.pdf> [2019, May 06].
- Flecknell, P. 2002. Replacement, reduction and refinement. *Altex*. 19(2):73–78.
- Fost, N. 2005. Gather ye shibboleths while ye may. *American Journal of Bioethics*. 5(5):14–15. DOI:10.1080/15265160500244983.
- Howell, J. 2017. Race and U.S. medical experimentation: the case of Tuskegee. *Cadernos de Saúde Pública*. 33. Available: http://www.scielo.br/scielo.php?script=sci_arttext&pid=S0102-311X2017001300301&nrm=iso [2019, May 06].
- Howell, E. & Obado-Joel, J. 2016. Human subjects protection in the African context. *African Evaluation Journal*. 4(1). DOI: <http://dx.doi.org/10.4102/aej.v4i1.106>.
- Kaiser, M. 2014. The integrity of science – lost in translation? *Best Practice & Research: Clinical Gastroenterology*. 28(2):339–347. DOI: 10.1016/j.bpg.2014.03.003.
- Monzon, J.E. & Monzon-Wyngaard, A. 2009. Ethics and biomedical engineering education: the continual defiance. *Conference Proceedings: IEEE Engineerirng in Medicine & Biology Society*. 2009:2011–2014. DOI:10.1109/iembs.2009.5333435.
- Park, S.S. & Grayson, M.H. 2008. Clinical research: protection of the “vulnerable”? *Journal of Allergy and Clinical Immunology*. 121(5):1103–1107. DOI: 10.1016/j.jaci.2008.01.014.
- Roy, B. 1995. The Tuskegee Syphilis Experiment: biotechnology and the administrative state. *Journal of the National Medical Association*. 87(1):56–67.
- Shuster, E. 1997. Fifty years later: the significance of the Nuremberg Code. *New England Journal of Medicine*. 337(20):1436–1440. DOI:10.1056/nejm199711133372006.
- Williams, G. 1959. *Virus hunter*. New York: Knopf.
- WMA. 2013. World Medical Association Declaration of Helsinki: ethical principles for medical research involving human subjects. *Journal of the American Medical Association*. 310(20):2191–2194. DOI:10.1001/jama.2013.281053.

Chapter 18

Intellectual Property Protection and Commercialisation

Y. Karanja & R.L. Murphy

Introduction

Developing a successful health technology requires several critical steps in order to achieve success. The starting point is an innovative idea with market potential, meaning that after the idea has been technically developed, it then must have the potential to be accepted by the intended end-users. To ensure acceptance, the idea needs to be tested by involving the end user and/or interested stakeholders, particularly in the case of medical devices intended for clinical use, as patient safety is at stake (Manbachi et al., 2018). These stakeholders can also provide valuable feedback during the iterative process of creating a product from the idea and creating product prototypes. Intellectual property protection may need to be sought to prevent the concept from being used and perhaps even marketed by another party. Intellectual property protection is also important for acquiring funding which will assist the company to create a working market-ready form of the product because protection of the intellectual property provides potential funders with a guarantee of exclusive market opportunities once the product is fully developed. Depending on the type of product, another critical step may include regulatory approval which may have to be sought before the product is allowed into the market.

This chapter presents an overview of the intellectual property rights that can be sought for a new innovation and discusses ways of commercialising a product after intellectual property protection has been obtained. It concludes with factors biomedical engineers should consider when turning a health technology idea into a product.

Intellectual Property Management

Intellectual property (IP) refers to the legal rights awarded for the use of human intellect in the development of something new or original in the industrial, scientific, literary or artistic fields (WIPO, 2004a). Intellectual property rights protect creations and ideas, giving the creator(s) and other producers of the intellectual goods or services recognition for, as well as control of the use of, their creation and its commercialisation (Fisher, 2001; WIPO, 2004b).

Intellectual property laws and rules are socially and economically important as the success of many companies depends on them (Fisher, 2001). Obtaining investment for an idea or concept that is not protected can be difficult. The creator is incentivised to protect their creation to guarantee a competitive advantage upon commercialising it. While intellectual property law can drive innovation, it may also limit it, because IP rights limit the use of certain technologies by other

people or companies (Flexman & Lazareck, 2007). A balance needs to be struck to foster economic development as well as future research (Spyropoulos, 2007).

In the sections below, the types of intellectual property rights and the steps in intellectual property development and protection are discussed.

Intellectual property can be categorised either as industrial property which consists of trademarks, patents, industrial designs and geographic indications, or as copyright (WIPO, 2004b). In some instances, multiple forms of protection can apply to an invention or creation.

Trademarks

A trademark is a word, phrase or symbol used to identify goods or services manufactured or supplied by a business. Trademarks can be awarded for the brand name, slogan, logo or shape and packaging of the product (Fisher, 2001, WIPO, 2004b). A trademark protects against counterfeiting by preventing the use of similar signs to market inferior products or services.

A trademark is obtained upon filing an application for registration with the national trademark office. If protection needs to be sought internationally an application needs to be filed at each national trademark office of interest (WIPO, 2004a). Alternatively, one can use the World Intellectual Property Organization's (WIPO) Madrid System which is a cost-efficient solution for registering and managing worldwide trademarks (WIPO, 2018a). A registered trademark can be protected for a lifetime if it is renewed every 10 years upon payment of a renewal fee. Trademarks can be sold, bought or licensed.

Patents

A patent is a right awarded for inventions (Fisher, 2001). The invention needs to be a product or process that is a new and non-obvious way of doing something or offers a new and non-obvious technical solution to a problem (WIPO, 2004b).

Patents protect the use of the invention and how it functions and last 20 years from the date of application (Streissguth, n.d.). In most countries, an annual renewal fee must be paid to keep a patent valid. In instances where the innovation is disruptive and has multiple inventions associated with it, an omnibus patent application should be considered (Capron & Wells, 2016).

Patents grant the owner exclusive rights to use, sell or license the invention. It also allows the patent holder to exclude others from manufacturing, using, copying, importing, exporting or selling the invention. When the patent expires, its protection ends and the invention enters the public domain making it available for commercial exploitation by others. The exclusive rights only relate to commercial exploitation of the invention, they do not prevent a person from running experimental work using the technological information from the patent specification (WIPO, 1997). Patenting

therefore does not protect against improving on the existing invention or discovering a different solution to satisfy the same market need. The patent owner is required to make all information regarding their invention available publicly. This enriches the body of technical knowledge in the world, promoting further creativity and innovation (WIPO, 2004b).

Patents are granted by national or regional patent offices. Regional patent offices include (WIPO, 2018b):

- African Intellectual Property Organization (OAPI)
- African Regional Intellectual Property Organization (ARIPO)
- Eurasian Patent Organization (EAPO)
- European Patent Organisation (EPO)
- Patent Office of the Cooperation Council for the Arab States of the Gulf (GCC Patent office)

The process of application differs from one regional office to the next. Filing an application with ARIPO involves specifying the member states in which protection is being sought. In OAPI, a single patent application is required when seeking protection in all member states while with the EPO the countries are selected after the patent has been granted.

Conditions of patentability

To be eligible for patent protection, an invention needs to meet several criteria, including that it must be: 1) useful, 2) novel, 3) inventive (non-obvious), 4) contain patentable subject matter (see below), and 5) have a comprehensive invention disclosure (WIPO, 2004a).

Patentable subject matter

Patent protection is available for inventions from all technology fields which can be categorised as: process, machine, manufacture, composition of matter or any new or useful improvement thereof (Rich, 1960; WIPO, 2004a).

In several countries computer software inventions, usually protected under copyright law, can be patentable. The computer software is patentable if its application is technical (“technical effect”) such as instructing a person skilled in the art on how to solve a particular problem using technical means (WIPO, 2004a). In some countries, such as the United States, a software package itself can be patentable even without a technical effect.

Fields of technology exempted from the scope of patentable subject matter in most countries are (WIPO, 2004a):

- Discoveries of materials or substances that already exist in nature.
- Mathematical methods and scientific theories.

- Human or animal treatment methods or diagnostic methods.
- Business schemes, rules or methods.
- Plant and animals and biological processes to produce plants and animals.
- Inventions where the commercial exploitation would contravene public order or morality.

Business schemes may be patentable in the United States.

Industrial applicability

A patentable invention cannot be purely theoretical, it must have a practical purpose. If the invention is intended to be a product, then it should be possible to fabricate it. If the invention is intended to be a process, it should be possible to demonstrate it in practice (WIPO, 2004a).

Novelty

An invention is considered as new if it has not been presented in the prior art anywhere in the world; which is all the knowledge that exists on the area prior to the relevant filing of the patent application (WIPO, 2004a). Knowledge on the prior art could exist either in writing or as documented oral disclosure.

The three ways in which prior art is disclosed are (WIPO, 2004a):

- By description of the invention in published writing or publication.
- By description of the invention in spoken words.
- Using the invention in public, referred to as disclosure by use.

Inventiveness

To be patentable, an invention must also be inventive. This means that it must *not be obvious to a person generally skilled in the art who has knowledge of prior solutions*. This test is very subjective and often a sticking point in getting an invention through the patent system.

Inventorship

The individuals who contribute to the innovative concept are referred to as inventors. Inventorship is a legal determination which is based on the contribution to the concept. In a patent application, the “true and only” inventors must be listed (Gattari, 2005). The omission of an inventor(s) or the inclusion of persons not involved in the inventive step is regarded as fraud and could result in the patent being nullified.

The invention process has two steps; first, the conception of the idea and second, the reduction of the idea into practice (Gattari, 2005). Reduction involves representing the invention in a physical

form. Inventorship focuses on the conception step, therefore, an individual who only spent time and effort reducing the invention is not considered an inventor but an enabler.

Joint inventorship results when two or more people collaborate on an invention, with each contributing to the subject matter. There is no specification in the law of the lower limit of contribution required to qualify as a joint inventor; only that the contribution is significant and inventive (Gattari, 2005). A contribution is significant if it helped make the work patentable, meaning novel and non-obvious.

In the United States, each joint inventor can sell or license their share of the patent without the permission of any other joint inventor. This, however, does not hold true in all countries.

Invention disclosure

Invention disclosure is a confidential document written by the creator of the invention to determine whether patent protection should be sought for the described invention, discovery, research tool, process, know-how or software (University of Texas at Austin, n.d.). In most cases, the invention disclosure is the first official record of the invention. An invention disclosure addresses the technical aspects of the invention while highlighting its novelty and non-obvious nature. It should clearly state the science behind the invention, its advantages over prior technologies, its potential drawbacks and the scope of use (Silverman, 1994).

The invention disclosure may be used to file for a provisional patent application, initiating the patenting and commercialisation process. To facilitate this, the invention disclosure needs to include the technical specifications of the invention. The technical specifications must contain a description of the invention and the manner and process of making and using it in full and exact details that can be understood by a person skilled in the art (Silverman, 1994; WIPO, 2004a). Full disclosure is required for a patent to be granted, meaning that a person skilled in the art should be able to recreate the invention without undue experimentation. It is important to note that it may not be necessary to disclose the “best method or design” but merely “a method or design”.

Public disclosure

Public disclosure of an invention involves making it readily available in enough detail that an individual with average technical knowledge in the area would be able to make and use the invention. Public disclosure could also include selling or offering to sell a prototype or showing or telling the ideas to a person who is not a collaborator or inventor of the technology and is not bound by a non-disclosure agreement (University of Texas at Austin, n.d.).

In most countries, patent rights are lost upon first public disclosure or publication. In the United States, however, the United States Patent and Trademark Office allows one year from the date of first public disclosure for one to file a patent (Silverman, 1994).

Patents are generally published by the respective patent offices. This usually takes place around 18 months from the first patent filing.

International Patent Classification (IPC)

The international patent classification is a hierarchical system used to classify patents depending on the technical area of application (WIPO, 2018c). The IPC has eight technology sections with about 70,000 subdivisions (Spyropoulos, 2007; WIPO, 2018c). This system assists with finding patent documents for research on prior art or in the development of technology. Other patent classification systems also exist.

Copyright

Copyright law protects original forms of expression such as, but not limited to: literary works, films, music, artistic works, computer programmes, databases and technical drawings (WIPO, 2004b). It is obtained automatically when the work is presented in a tangible medium without the need for registration. The right holder of the work can authorise or prevent:

- The reproduction of the work in any form.
- Its broadcasting.
- Its translation into other languages.
- Its public performance and communication to the public.
- Its adaptation.

Despite registration not being necessary, a copyright can be registered at the national or regional copyright office. Registration of the copyright is advantageous in that it provides proof of ownership and legal recourse in case of infringement. Copyright registration is effective on the date of submission of the completed application, filing fee and copies of the work being registered (Haskins, 2015). The duration of the copyright protection is the life of the creator(s) plus a number of years after their death. Copyright can be passed down by inheritance.

Industrial or registered designs (Design Patents)

Industrial or registered design protects the ornamental and aesthetic appearance of a product (WIPO, 2004b). In the United States it is referred to as “design patent” (Horbal, 2014). Industrial design refers to the three-dimensional (shape) or two-dimensional (pattern or colour) features of the product. Industrial designs are applied to a wide range of products such as technical and medical instruments, jewellery, house wares, vehicles, textiles and architectural structures. Designs protected in this way need to be new or original and non-functional, i.e. for aesthetic purposes (WIPO, 2004b). In some countries, such as South Africa, it is possible to register a functional design. It differs from a true patent in that a functional design still protects the appearance of an article, only here the appearance is dictated by the function it is to perform, e.g. a shoe tread.

Industrial designs are protected as they add to the appeal of a product increasing its commercial value and marketability. The owner is, therefore, protected against unauthorised copying or imitation of the design.

If an industrial design is considered novel or original, in that it has not previously been disclosed in public, an application for registration can be filed at the regional or national IP office. The term of protection is generally for 5–15 years, and is limited to the country in which

the protection was granted. Sometimes maintenance fees are required to keep the design in force to the end of its term. In USA design patents last 14 years from the date of approval without any maintenance fee (Streissguth, n.d.).

Trade secrets

Trade secrets protect commercially available information such as food recipes or marketing strategies in an attempt to conceal them from competitors in the industry (Fisher, 2001). Information protected in trade secrets could be patentable if it is novel and non-obvious. Trade secrets are protected without registration for an unlimited period of time. There are, however, some conditions that need to be met in order for the information to be protected as a trade secret by Article 39 of the Agreement on Trade-Related Aspects of Intellectual Property Rights (TRIPS Agreement), which has 162 member nations (International Trademark Association, 1997) which protects against the unauthorised use of undisclosed information (Makoko & Olivier, 2017):

- It must have commercial value because it is secret.
- The information must be secret.
- It must be subject to reasonable steps by the holder to keep it secret.

If a product or process can easily be reverse engineered, an IP strategy would rather rely on patents. If it cannot be reverse engineered, then it may be beneficial to keep the information secret.

Geographical indications

Geographical indications are signs placed on products from a specific geographical origin and possess qualities or reputation that are due to that origin (WIPO, 2013). Geographical indication prevents the use of the sign for products that do not meet the standard. However, it does not protect against the product being made by replicating the same technique set out in the standards (WIPO, 2013). Geographical indications are used for agricultural products, foodstuffs, wine and spirits, handicrafts and industrial products (WIPO, 2013). Implementation of geographic indications is governed by the TRIPS Agreement in Articles 21-24 (International Trademark Association, 1997).

Steps in Intellectual Property Protection

With the variety of IP available, the first step would be to conduct an audit to determine the IP, registered or unregistered, for which one is eligible (Bridgett, 2015). Thereafter, it is essential to protect the brand, slogan, symbol, or company name as a trademark. Trademark databases can be checked to avoid using existing or protected trademarks.

If an invention meets the conditions of patentability, some factors need to be considered before filing (European Patent Office, 2011):

- Is the patent necessary or can a combination of other IP applications protect the invention?
- Is the cost of patenting (including annual costs) justifiable when compared to the earnings from the invention?
- What is the life cycle of the invention? The patenting process takes 3 to 4 years and in technological fields where products change rapidly, applying for a patent may be a limitation.
- The timing of the application needs to be planned. If it is filed too early the product may not be ready for commercialisation, with most of the patent lifespan spent trying to create a marketable product (this holds true particularly for medical devices and pharmaceuticals where clinical trials need to be factored into the development timeline). If the application is filed too late, someone else may file first. In addition, the patenting process is a sequence of events determined by international conventions and treaties; once started they cannot be delayed.
- The patent owner is responsible for enforcing the patent, which will incur additional costs.

If patenting is justifiable, a priority application is filed in at least one country, typically the country of residence of the inventor. If it is necessary to apply for jurisdiction in other countries, this needs to be done within 12 months of first filing. One can either file directly in other countries at this point, or file an international patent application with the Patent Cooperation Treaty (PCT). With the PCT one can seek patent protection in over 150 countries depending on the application. With this single application, multiple patent applications are being made in different countries of interest.

The PCT process has two main phases, the international phase and the national phase. The international phase begins with filing and submitting the international application to a PCT-affiliated patent office. After filing a PCT, an international search by an International Searching Authority (ISA) identifies patents, publications and technical literature that relate to the invention and writes an opinion on the potential patentability of the invention. After 18 months from the earliest filing date, the contents of the international application are publicly disclosed. At the end of the international phase, about 30 months from the earliest filing date, is the national phase. At this stage, the applicant must select the countries where protection is sought. This can be done by filing the PCT patent specification at the individual patent offices. Regardless of the outcome of the PCT search report and opinion, the patent application will still be examined by each patent office individually; in most countries this would include a full patentability examination. However, the benefit of filing a PCT is that it postpones the decision to choose countries until 30 months after the first filing, which has a cash flow benefit for most companies and allows them more time to assess which markets are to be protected.

Commercialisation

The innovation process involves the ideation or conception phase, the design and development phase, the prototype phase and the production, marketing and commercialisation phase (Manbachi et al., 2018; WIPO, 1997). Commercialisation is therefore the final step of the innovation process. At this stage the invention is introduced to the market and can begin to generate income to compensate the innovators and manufacturers for their efforts.

Finding an innovative solution to a problem does not guarantee commercial success. Interaction with various stakeholders during the innovation and commercialisation stages is usually required. Networking and building formal networks with key players in industry, venture capitalists and business angels is essential for creating a successful commercialisation strategy (Ismail, Omar & Majid, 2011). There are various avenues an inventor could use to commercialise; they include:

- Licensing the rights to the invention.
- Assigning or selling the patent rights.
- Starting their own business as a start-up or spin-off.

The following sections will describe these commercialisation paths in more detail.

Licensing

Licensing is the leasing of a legally protected property such as a trademark, copyright or patent to another party (CIPC, 2018; WIPO, 1997). The contractual agreement between the owner of the property (licensor) and the commercial partner (licensee) grants the licensee permission to use the property. Sometimes the licensee is allowed to sub-license the IP to a manufacturer. In exchange, the licensee must pay the licensor a fee or royalties for the access. Specific terms and conditions may be attached to the use such as the purpose of use (limited to certain applications or methods of use of the technology), a defined territory or nation, and a defined time (CIPC, 2018; Ismail, Omar & Majid; 2011; WIPO, 1997). Licences can be non-exclusive, where the licence may be granted to several companies, or exclusive to a single company (Ismail, Omar & Majid, 2011).

Assignment

Assignment is the sale of the IP transferring ownership of the IP to an assignee. This is a business strategy for those who prefer a lump-sum payment over smaller royalty payments over time (CIPC, 2018). The assignor loses all control of over the intellectual property upon payment, but the assignment agreement may include terms that allow for the IP to “fall” back to the assignor in an event where the assignee is not successfully commercialising the IP.

Start-up and spin-off companies

A start-up is a newly formed company which focuses on a product that is not being offered in the market or an alternative to a product in the market that the founders believe is inferior (Fontinelle, 2017; Robehmed, 2013).

In the initial stages, start-up companies have higher expenses than their revenue levels. This is due to the focus on development, testing and marketing of the product. Financing the start-up through loans, government funding, grants from non-governmental organisations or angel investors is essential for their success (Manbachi et al., 2018; Robehmed, 2013). Incubators and accelerators provide start-ups with capital, advice and work space (Manbachi et al., 2018; Robehmed, 2013).

A spin-off or spin-out is the creation of an independent company by a parent company or organisation (Financial Times, n.d.). In many cases, this refers to a company formed by a university to commercialise an invention designed by its academics or students. The disruptive nature of the IP is an important factor in the decision to start a company. In some cases, licencing might be a better option.

Additional considerations for biomedical engineers

One of the most important stages in bringing the products of biomedical engineering to the market, is obtaining regulatory approval. Regulatory approval could take years to obtain and requires a significant amount of money. This is because thorough preclinical tests followed by clinical evaluations are required to prove the safety and efficacy of the invention. Only if these tests are successful can one file an application for, and be granted, regulatory approval.

The adoption of an invention by the health care sector may take some time due to the resistance presented by clinicians to change (Wang, Butner & Darzi, 2006). Some technologies may require clinicians to move away from an established technique or process, introducing a new learning curve. In addition, reimbursement, for example via insurance, needs to be considered in parallel with the regulatory and clinical strategies to ensure that the product is affordable and accessible to its target market. Thus, the road to establishing a health technology company or bringing a health technology product to market, can be costly and long.

For academic biomedical engineers, the relationship with the university and the inventor must be clarified before any disclosure of an invention is made. A defined institutional policy benefits all parties as the inventor is guaranteed not only intellectual and academic rewards, but financial ones as well. The institution benefits by ensuring that its innovations are developed to maximize society's use in addition to promoting economic growth. They will also benefit financially in the event a product is successfully commercialized while retaining some of their most talented and productive faculty. For universities, profit should not be a motivator in bringing research to the market as it is not the primary mission of a university, the time lines to development are long, and it is near impossible to predict which discoveries will result in significant licensing fees, start-up companies or initial public offerings (IPOs).

The timeline for development of a successful commercial biomedical product from a university inventor may take as long as 15–20 years (Figure 1). The steps involved include:

1. *Research.* Whether funded locally or by an extramural source, this critical first step is essential in the development process. The university should nurture research activities that may lead to innovations that can benefit society. Only a small fraction of the research activities in a university setting will result in a commercial success, however without research, there is no such success. It is almost impossible to select “winners” at the basic research level.
2. *Disclosure.* Inventors need to be educated about the benefit of initial disclosure of their product or invention. Eagerness to publish or present innovative results prior to disclosure can invalidate any future patent claim.

3. *Patents.* Not every disclosure warrants a patent submission. Approximately one half of disclosures will require a patent. Further development of the product continues after patent application.
4. *License.* Once a product or invention has been successfully developed to at least the prototype phase, the inventor has two options: 1) license the product to a commercial entity that can refine development and bring the product to market, or 2) form a start-up company which will continue the development and commercialisation. The licensing approach is certainly the easiest where the licensee takes on the development risks and costs, and the licensor (the university and inventor) accept a royalty in return for giving up the product rights. The start-up company approach is much longer and riskier for the inventor and requires starting a company, raising funds, clinically validating the product, performing market analyses and launching the product into the marketplace. Successful start-ups may be purchased or merged, or may raise more funds through an IPO. While the start-up approach is much more difficult and riskier, when successful, it is typically more profitable.
5. *Profits.* Figure 1 shows the typical time lines from research to profits at universities. In a robust academic research environment, many millions of dollars may be invested in research, resulting in, for example, 1000 disclosures. Of the 1000 disclosures, approximately 500 will typically be patentable. Of the patented products in such an environment, as many as 150 could be expected to be licensed and up to 15 new companies started. Of all the licensed products, only 1 or 2 would be expected to generate an annual licensing fee. Of the 15 start-up companies formed, it would be reasonable to expect that one IPO would occur.

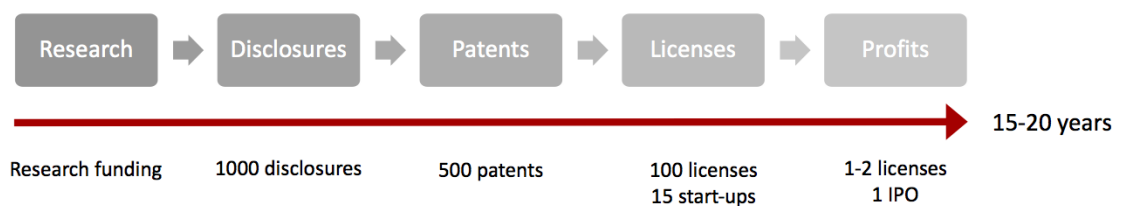

Figure 1. Adapted, with permission, from material provided by Professor Alicia Loffler, Innovation and New Ventures Office, Northwestern University.

Summary

Developing novel biomedical products including drugs, devices, assays, and equipment is a lengthy process that starts with an innovative idea that potentially meets a critical medical need. Research universities worldwide are filled with experienced and talented researchers capable of developing their innovative ideas into useful and valuable medical products. The process is long and high-risk, but rewarding on many levels. The university role ranges from educating the innovators to developing prototypes. Universities may even assist in licensing and start-up activities. A robust

development pipeline involves identification and protection of the intellectual property and a clear, well defined partnership between the institution and its inventors.

Acknowledgements

The authors are grateful to Mr Philip Hoekstra from Research Contracts & Innovation at the University of Cape Town and Professor Alicia Loffler, Associate Provost for Innovation and New Ventures at Northwestern University in Evanston, Illinois, USA for their insights on intellectual property protection.

References

- International Trademark Association. 1997. *Protection of geographical indications and trademarks*. Available: <http://www.inta.org/Advocacy/Pages/ProtectionofGeographical-IndicationsandTrademarks.aspx>
- Bridgett, N. 2015. *Four step guide to protecting your intellectual property internationally*. Design Council. Available: <https://www.designcouncil.org.uk/news-opinion/four-step-guide-protecting-your-intellectual-property-internationally> [2019, May 06].
- Capron, A. & Wells, R. 2016. *How digital health startups can leverage intellectual property*. HIT Consultant Media. Available: <https://hitconsultant.net/2016/01/18/digital-health-startups-intellectual-property/> [2019, May 06].
- CIPC. 2018. *Commercialising your IP*. Companies and Intellectual Property Commission. Available: <http://www.cipc.co.za/index.php/trade-marks-patents-designs-copyright/commercialising-your-ip/> [2019, May 06].
- European Patent Office, 2011. *The patenting process*. Available: <https://www.epo.org/learning-events/materials/inventors-handbook/protection/patents.html> [2019, May 06].
- Financial Times. n.d. *Definition of spin-off*. [ft.com/lexicon](http://lexicon.ft.com/lexicon). Available: http://lexicon.ft.com/Term?term=spin_off [2019, May 06].
- Fisher, W. 2001. Theories of intellectual property. In: *New essays in the legal and political theory of property*. S. Munzer, ed. Cambridge University Press. 168–199.
- Flexman, J.A. & Lazareck, L. 2007. Biomedical engineering and society: Policy and ethics. *Conference Proceedings: IEEE Engineering in Medicine & Biology Society*. 6156–6158.
- Fontinelle, A. 2017. *What exactly is a startup?* Investopedia. Available: <https://www.investopedia.com/ask/answers/12/what-is-a-startup.asp> [2019, May 06].
- Gattari, P.G. 2005. Determining inventorship for US patent applications. *Intellectual Property & Technology Law Journal*. 17(5):4.
- Haskins, J. 2015. *Understanding the copyright registration process*. Available: <https://www.legalzoom.com/articles/understanding-the-copyright-registration-process> [2019, May 06].
- Horbal, P. 2014. *The difference between patents and industrial designs*. Bereskin & Parr. Available: <http://www.bereskinparr.com/doc/the-difference-between-patents-and-industrial-designs> [2019, May 06].
- Ismail, K., Omar, W.Z.W. & Majid, I.A. 2011. The commercialisation process of patents by universities. *African Journal of Business Management*. 5(17):7198.

- Makoko, M. & Olivier, D. 2017. *What are trade secrets and how do we protect them?* golegal. Available: <https://www.golegal.co.za/protect-trade-secrets/> [2019, May 06].
- Manbachi, A., Kreamer-Tonin, K., Walch, P., Gamo, N.J., Khoshakhlagh, P., Zhang, Y.S., Montague, C., Acharya, S. et al. 2018. Starting a medical technology venture as a young academic innovator or student entrepreneur. *Annals of Biomedical Engineering*. 46(1):1–13.
- Rich, G.S. 1960. The principles of patentability. *Journal of the Patent and Trademark Office Society*. 42:75.
- Robehmed, N. 2013. *What is a startup?* Forbes. Available: <https://www.forbes.com/sites/natalierobehmed/2013/12/16/what-is-a-startup/#695a4540440c> [2019, May 06].
- Silverman, A.B. 1994. Writing an effective invention disclosure. *JOM*. 46(4):70.
- Spyropoulos, B.P. 2007. Design and implementation of a course on intellectual property rights for graduating biomedical engineering students. *Conference Proceedings: World Congress on Medical Physics and Biomedical Engineering*. 3798–3802.
- Streissguth, T. n.d. *What is the lifespan of a patent?* Legalzoom. Available: <http://info.legalzoom.com/lifespan-patent-20560.html> [2019, May 06]
- University of Texas at Austin. n.d. *Invention disclosure: #2 in the 8 steps of tech commercialization*. Available: <https://research.utexas.edu/otc/process-of-technology-commercialization/invention-disclosure-2-in-the-8-steps-of-tech-commercialization/> [2019, May 06].
- Wang, Y., Butner, S.E. & Darzi, A. 2006. The developing market for medical robotics. *Proceedings of the IEEE*. 94(9):1763–1771.
- WIPO. 1997. *Introduction to commercialization of patented inventions different options: manufacturing, licensing patent rights, selling patent rights*. Available: https://www.wipo.int/meetings/en/doc_details.jsp?doc_id=637 [2019, May 06].
- WIPO. 2004a. *WIPO intellectual property handbook*. Available: <https://www.wipo.int/about-ip/en/iprm/> [2019, May 06].
- WIPO. 2004b. *What is intellectual property?* Available: <https://www.wipo.int/about-ip/en/> [2019, May 06].
- WIPO. 2013. *Geographical indications: An introduction*. Available: <https://www.wipo.int/publications/en/details.jsp?id=272> [2019, May 06].
- WIPO. 2018a. *Madrid – The international trademark system*. Available: <https://www.wipo.int/madrid/en/> [2019, May 06].
- WIPO. 2018b. *Examination by a regional patent office*. Available: <https://www.wipo.int/patents/en/topics/worksharing/regional-patentoffices.html> [2019, May 06].
- WIPO. 2018c. *International patent classification (IPC)*. Available: <https://www.wipo.int/classifications/ipc/en/> [2019, May 06].

Chapter 19

Medical Device Regulation in Africa

T. Saidi & T.S. Douglas

Introduction

Medical devices facilitate the diagnosis and treatment of diseases to improve patients' health and quality of life. They range from simple but essential items to sophisticated equipment. The use of medical devices for patient care occurs in different settings such as the bedside, rural health clinics, or large, specialised hospitals (Cheng, 2003). Due to the nature of their use in the health sector, the manufacture and subsequent entry of medical devices into the market is held to a higher standard than for any other product (McAllister & Jeswiet, 2003). It is therefore imperative to define the requirements for the design, development and manufacture of medical devices to ensure that products that reach the market are safe, effective and of good quality, while restricting entry of products that pose risks.

Various countries across the world have established regulatory bodies that guide the medical device industry. For example, medical devices in the USA are regulated under the Medical Device Amendments of 1976, which stipulate the requirements for ensuring safety and effectiveness in the production, registration and marketing of devices (Gottlieb, 2011; Kramer, Xu & Kesselheim, 2012). According to these regulations, manufacturers of high-risk devices such as heart valves are required to demonstrate safety and effectiveness before they can be marketed (Kramer, Xu & Kesselheim, 2012; Sorenson & Drummond, 2014). In the Europe Union, the Medical Device Regulation of 2017 sets the required standards for design, safety and performance for medical devices (EU, 2017). However, the regulation of medical devices is still rudimentary in many developing countries, where regulatory controls are not yet well established to prevent the importation or use of sub-standard devices (Lamph, 2012). It is against this background that this chapter explores medical device regulation in Africa.

The chapter is based on a review of literature extracted using keywords linked to medical device regulation in selected African countries. The documents include reports from the World Health Organisation, journal articles and newspapers. We draw heavily on grey literature because the regulation of medical devices is evolving and relevant documents often appear in the form of reports and communications by government agencies and national and international coordinating bodies. The chapter commences with an overview of international regulations and standards for medical devices.

Since the medical device industry is capital intensive, costing governments a substantial amount of money (Cheng, 2003; Moorthy, 2016), we focus on the ten African countries with the highest GDP – Kenya, Nigeria, Egypt, Sudan, Morocco, Angola, Algeria, Tanzania, Ethiopia and South Africa (World Bank, 2017). An overview is provided of the medical device regulations of these countries, and the implications for the development of their domestic medical device industries are considered.

International regulations and standards

The World Health Organisation promotes the regulation of medical devices across the world. In 2007, it adopted World Health Assembly Resolution 60.29, which encourages the promulgation of national or regional guidelines for good manufacturing and regulatory practices and establishment of surveillance systems and other measures aimed at ensuring quality, safety and efficacy of medical devices (WHO, 2011). The regulatory system is anchored in medical device classification focusing on perceived hazards.

Countries across the world use different classification schemes for medical devices and these depend on design complexity, use characteristics, and potential for harm if misused. Topics such as the degree of invasiveness, the duration of contact, and the body system affected are given attention (Cheng, 2003). In support of World Health Organisation initiatives to minimise regulatory barriers, the Global Harmonisation Task Force proposed regulatory classes for medical devices (GHTF, 2007). These classes determine the level of assessment required; Class I applies to medical devices that pose the lowest potential risk and may not need a licence, and Class II demands the manufacturer's declaration of device safety and effectiveness, while devices presenting a greater potential risk that calls for a rigorous assessment, fall under Class III and Class IV. The drive was towards standardisation of regulations as the founding members of GHTF namely Australia, Canada, Japan, the European Union and the USA used different classification systems (Cheng, 2003). For example, the USA categorises medical devices into three classes while Canada and Japan assign four classes (Altenstetter, 2012). The European Union classifies medical devices into three classes with Class II being sub-divided into IIa and IIb (Cheng, 2003; Greenspan, 2013). The Global Harmonisation Task Force was disbanded in 2012 and replaced by the International Medical Device Regulators Forum which is aimed at accelerating harmonisation and convergence to achieve greater uniformity between national regulatory systems (Tamura & Kutsumi, 2014). The World Health Organisation in 2014 adopted a resolution (WHA 67.20) for strengthening the regulatory system for medical products (WHO, 2017).

Quality standards are applied to the design, manufacturing and distribution of medical devices. Such standards are aimed at ensuring that customers receive products that meet both regulations and safety expectations (Cheng, 2003; Mitra, 2016). For example, compliance with the ISO 13485 quality management system, which prioritises risk reduction and safety, is a requirement for producing medical devices with a risk classification above Class I (Brown et al., 2008; Mitra, 2016).

ISO 9001 specifies a quality management system for consistent provision of products and services that meet customer and regulatory requirements (Schlickman, 2003). Donors and purchasing organisations, such as the United Nations and the Global Fund, commonly require medical devices to be manufactured at a site compliant with ISO 13485 or ISO 9001 (UNFPA, 2015). With the procurement of medical devices being driven by conformity to regulations, manufacturers who are in possession of ISO 13485 and/or ISO 9001 have an edge in the market over those who do not (Cheng, 2003; Hoyle, 2017).

Regulation of medical devices in Africa

In Kenya, the regulation of medical devices is the responsibility of the Pharmacy and Poisons Board which is a regulatory authority established under the Pharmacy and Poisons Act, Chapter 244 (WHO, 2017). Its core mandate is to regulate the practice of pharmacy and the trade in drugs, poisons, medical products and health technologies (Rugera et al., 2014; WHO, 2017). All imported medical devices are subject to pre-export verification of conformity to standards through a programme implemented by the Kenya Bureau of Standards (KEBS, 2017). It is mandatory for importers of medical devices in Kenya to obtain certificates of conformity for their cargo prior to applying for import permits from the Pharmacy and Poisons Board through the Kenya National Single Window Electronic System (Technofreight, 2017). The regulation of imports in Kenya is important as the country relies heavily on products brought from other countries (Lilech, 2014).

In Nigeria, the regulation of medical devices is the responsibility of the National Agency for Food and Drug Administration and Control under the provisions of Act CAP F33 LFN 2004 and the accompanying guidelines (NAFDAC, 2005). According to NAFDAC, medical devices must be registered first before they are manufactured, imported, exported, advertised, sold or distributed in Nigeria (WHO, 2017). The regulations are aimed at controlling unscrupulous entry of imported products into the country. Foreign manufacturers are required to provide evidence that they are licensed to manufacture medical devices for sale in the country of origin and that the imported medical devices do not contravene the laws of the country of origin (NAFDAC, 2005). With regard to the import of a new medical device, evidence is needed to the effect that the product is registered in the exporting country and the ingredients are approved. To facilitate monitoring and evaluation of the medical devices that are imported to Nigeria, the regulations require representation of foreign manufacturers by a duly registered company or individual with facilities to effect recall of imported products when necessary (Erhun, Babalola & Erhun, 2001). In addition, a trademark registration is a required before a medical device is licensed.

With regard to Egypt, the registration and approval of medical devices require compliance with the Central Administration of Pharmaceutical Affairs, a division of the Egyptian Ministry of Health that oversees the country's medical device market (Gad et al., 2016). A specialised committee for the study of manufactured and imported medical devices and equipment has the mandate of controlling the registration process. The committee is made up of experts with a medical

background from different specialities such as ophthalmology, orthopaedics, surgery, cardiology, pharmacy and biomedical engineering (US. Department of Commerce, 2006). The key task of the committee is to review and approve applications for the manufacture and/or importation of medical devices. Evaluation of applications includes particular attention to the intended use of the medical device and establishing whether there is a real need and benefit for patients (Gad et al., 2016). The Medical Device Safety Department within the Central Administration of Pharmaceutical Affairs is a separate entity tasked with regulating the medical device market in Egypt (WHO, 2017). The importation of used and refurbished medical devices is banned in Egypt and an importer is required to present an original certificate from the manufacturer indicating the production year of the equipment and that it is new and safe (US. Department of Commerce, 2006). Although medical device market access in Egypt is uncomplicated if there is proof of authorisation to sell a product in a reference country, the system has shortfalls in terms of ensuring patient safety and enabling fast access to innovations; for example, the interim nature of medical device legislation, lack of transparency, and poor management of electronic databases, combined with pervasive corruption, present formidable barriers in the regulation of medical devices in Egypt (Gad et al., 2016).

In Sudan, the regulation of medical devices is undertaken by the National Medicines and Poisons Board (WHO, 2017). This regulatory body is responsible for the implementation of medical device regulations in collaboration with the Department of National Health Technology Management and Assessment (FMoH, 2011; Omer, 2016). Medical devices are regulated under the Pharmacy, Poisons, Cosmetic and Medical Devices Act 2001, which controls the sale, distribution and supply of medical devices (Ali & Omer, 2012). The regulation of medical devices stretches from pre-market approval to post-market surveillance. The regulation of medical devices in Sudan is similar to that for medicines, food, and other medical products (Omer, 2016). The regulation makes provisions for donated medical devices which are issued a temporary import license and are required to meet general criteria covering equipment quality, safety, compliance with specifications and standards, non-obsolescence, and appropriateness of the medical device for the user environment (FMoH, 2011). There is emphasis on safeguarding quality with respect to donations, and when the quality is unacceptable in the donor country, the device is also considered inappropriate as a donation.

The importation and registration of medical devices in Morocco is the responsibility of the Moroccan Ministry of Health through the Medical Devices Advisory Committee (Samadi, 2015). Medical devices other than radiation equipment require approval from the Ministry of Health showing compliance with Moroccan health standards. The country recognises certifications provided by the FDA. About 20 percent of imported medical equipment in Morocco is used or reconditioned. Importers of used medical devices are required to provide Moroccan buyers with FDA authorisation, technical documentation and directions for use of the product, electro-technical and radiation safety certification, and documentation on previous maintenance (Harper, 2003). Prior to 2015, registration was compulsory for all second-hand medical equipment within

12 months of purchase. There is a new law under consideration which calls for banning the purchase of used medical devices and equipment in the country (Berrami, 2016). The regulations for medical devices lack a risk-based classification (MD24, 2015). Instead, they are classified by function according to the duration of use, degree of invasiveness, means of use (surgical or not), activity, and use on the body (WHO, 2014).

Angola has developed regulations for medicines and other pharmaceutical products which apply across the public and private sector, but the country does not have a comprehensive regulatory system that is specific to medical devices (Thumm et al., 2013). Medical devices are regulated by the National Pharmaceutical Policy of 2010, which stipulates the registration, roles and responsibilities of different actors and requirements for quality assurance (Thumm et al., 2013). The National Directorate for Pharmaceuticals and Equipment, which falls under the Ministry of Health in Angola, is the regulatory body that sets the criteria for the entry of pharmaceuticals and medical equipment in the country (Nogueira, 2017). The Health Inspection Office of the Ministry of Health ensures that the medical devices imported into the country meet required norms and standards.

Medical devices in Algeria are regulated by the Directorate of Pharmacy in collaboration with the National Laboratory for the Control of Pharmaceutical Products, which falls under the supervision of the Ministry of Health and Population (Samadi, 2015). The classification system of medical devices is similar to the EU system (Classes I, IIa, IIb and III). It is a requirement that medical devices be registered and manufacturers with no local presence are required to appoint a local authorised representative responsible for the registration process and submission of the documentation to the Directorate of Pharmacy (THEMA-MED, 2015). Medical devices require approval before being placed on the market and imports must meet conformity requirements (WHO, 2017).

In Tanzania, the Food and Drugs Authority regulates the quality, safety and performance of medical device (Lissel et al., 2016). The regulatory provisions for medical devices in Tanzania are stipulated in the Food, Drugs and Cosmetics (Control of Medical Devices) Act of 2015 which controls the registration of medical products. According to the Act, no person shall sell, manufacture, import or export, distribute, provide as a grant or gift or offer for sale any medical device unless it is registered by the authority (TFDA, 2016). Medical devices in Tanzania are classified into class A, B, C and D depending on the level of risk, which is in line with the principles of medical device classification as stipulated by the Global Harmonisation Task Force on medical devices (WHO, 2016a). The approval of a medical device for registration is on condition that its availability is in the public interest, it is safe, efficacious and of acceptable quality, and its manufacturing premises and operations comply with good manufacturing practices (Ndamugoba, 2017).

Medical devices in Ethiopia are regulated by the Food, Medicine and Healthcare Administration and Control Authority of Ethiopia (Gebreab & Wolyei, 2014). Medical devices are classified based on risk to the human body. An agency agreement is required between the manufacturer of a medical device for registration and the agent responsible for the import, distribution, and sale of the product in Ethiopia (FMHACA, 2014). The authorisation process for medical devices in Ethiopia includes inspection of the manufacturing premises, assessment for good manufacturing practice compliance, and conducting laboratory testing where applicable (Suleman et al., 2016). A manufacturer of medical devices in Ethiopia is required to attest that the product complies fully with all applicable essential principles for safety and performance (FMHACA, 2014).

In South Africa, medical devices are regulated by the newly enacted Medicines and Related Substances Amendment Act, 14 of 2015 (Kirby, 2017). The Act provides for the establishment of the South African Health Products Regulatory Authority, a body in charge of regulatory oversight for medicines, medical devices, complementary medicines, foodstuffs, cosmetics, and related substances (Gray & Vawda, 2016). The regulation of medical devices is based on a four-tier, risk-based classification system for obtaining device licences for manufacturers, importers and distributors. The distribution of medical devices and in vitro diagnostic devices (IVDs) in South Africa is subject to regulations depending on the level of risk and the intended use (Eisenhart, 2016). Only registered products are sold in South Africa as the regulation does not allow a manufacturer, wholesaler or distributor of medical or IVD devices to manufacture, act as a wholesaler of, or distribute, any medical device or IVD without a valid licence (Khan, 2017).

Implications for the development of the medical device industry in Africa

The establishment of medical device regulations is an important step towards better health for a country's population. The question then becomes how the regulations are formulated and implemented to support the local medical device industry. An overview of the regulation of medical devices in the ten countries discussed in this chapter reveals some interesting insights which may influence the development of African medical device industries.

The regulations described in this chapter have a strong focus on imports. This is not surprising given heavy reliance on medical devices from developed countries. For example, South Africa, Nigeria and Egypt, which are considered to be the largest markets and economies in Africa, continue to be dominated by the supply of orthopaedics, prosthetics, patient aids and consumables from the USA (Nagel, 2017). Few local companies manufacture products for the domestic and export markets. The regulatory approval process for medical devices in Africa is lengthy, not transparent and skewed towards controlling of entry into the market of substandard imports which are a risk to health (McNerney & Peeling, 2015).

None of the ten African countries discussed have specific regulations or regulatory bodies dedicated to medical devices. Instead, the regulations are presented broadly to cover medicines, foodstuffs, cosmetics, and related substances. Although established regulatory frameworks such as that of the FDA are broad in their approach to regulation, encompassing many types of product, they however have divisions and trained personnel for the regulation of medical devices specifically. This is not the case with the African countries reviewed, as they likely lack the resources and a critical mass of skilled personnel to focus solely on the regulation of medical devices. Under such conditions, the regulatory bodies may fail to cope with registrations of medical devices, which would result in delays and ultimately lack of access to medical devices by the public.

Medical device regulations in Africa are designed along the framework of models used in developed countries. For example, the requirements for importation and exportation of medical devices in South Africa, Algeria, Kenya and Ethiopia are similar to the internationally recognised certification/registration programmes of the European CE Mark, the US FDA and the Australian Hybrid Therapeutic Goods Administration. This is important in that it aligns African countries with a harmonised framework for medical device regulation. The World Health Organisation encourages the harmonisation of medical device regulation, towards standardisation to promote uniformity between national medical device bodies. In an era of globalisation, this facilitates cooperation among regulators and the industry, particularly with regard to audits, submission requirements, use of international standards, and exchange of safety information, and leverages experience gained over time.

Beyond regulations, much could be done to promote the development of medical device industries in African countries. An example is preferential procurement of domestically manufactured medical devices, as part of wider industrial policy (Deloitte & Touche, 2014). This would involve allocating some government spending to domestic manufacturers to increase demand for home-grown products and enhance the level of local content on the market. Furthermore, measures can put in place to enhance the technology and production capacity of the local industry. In Ethiopia, Ghana, Kenya and Tanzania, a World Health Organization framework for local production and access to essential medical products is being implemented to stimulate innovation and provide appropriate technical assistance, towards establishing a viable and competitive domestic medical device industry (WHO, 2016b). Thus African governments can play a leading role in encouraging the development of their domestic medical device industries, not only by establishing medical device regulations and providing adequate resources for their implementation, but also through broader policy considerations.

References

- Ali, G.K. & Omer, A.M. 2012. Pharmaceuticals in Sudan: development in regulations, governance and implementation of national drug policies. *African Journal of Pharmacy and Pharmacology*. 6(1):1–12.
- Altenstetter, C. 2012. Medical device regulation in the European Union, Japan and the United States. Commonalities, differences and challenges. *Innovation: The European Journal of Social Science Research*. 25(4):362–388.
- Berrami, H. 2016. *Healthcare resource guide: Morocco*. Available: https://2016.export.gov/industry/health/healthcareresourceguide/eg_main_092016.asp. [2019, May 20].
- Brown, A., Eatock, J., Dixon, D., Meenan, B.J. & Anderson, J. 2008. Quality and continuous improvement in medical device manufacturing. *The TQM Journal*. 20(6):541–555.
- Cheng, M. 2003. *Medical device regulations: global overview and guiding principles*. Available: <https://apps.who.int/iris/handle/10665/42744> [2019, May 14].
- Deloitte & Touche. 2014. *Research to guide the development of strategy for the medical devices sector of South Africa*. Available: <http://www.samed.org.za/DynamicData/LibraryDownloads/60.pdf> [2019, May 14].
- Eisenhart, S. 2016. *South African medical device regulatory system set for implementation*. Cape Town. Available: <https://www.emergogroup.com/blog/2016/08/south-african-medical-device-regulatory-system-set-implementation> [2019, May 14].
- Erhun, W., Babalola, O. & Erhun, M. 2001. Drug regulation and control in Nigeria: the challenge of counterfeit drugs. *Journal of Health & Population in Developing Countries*. 4(2):23–34.
- EU. 2017. Regulation (EU) 2017/745 of the European Parliament and of the Council of 5 April 2017 on medical devices, amending Directive 2001/83/EC, Regulation (EC) No 178/2002 and Regulation (EC) No 1223/2009 and repealing Council Directives 90/385/EEC and 93/42/EEC. *Official Journal of the European Union*. Available: <https://www.emergogroup.com/sites/default/files/europe-medical-devices-regulation.pdf> [2019, May 14].
- FMHACA. 2014. *Guideline for registration of medical devices*. Available: <http://apps.who.int/medicinedocs/documents/s23057en/s23057en.pdf>. [2019, May 20].
- FMoH. 2011. *Health technology management policy (medical devices)*. Available: http://www.fmoh.gov.sd/Health-policy/Sudan-HTA&M-Policy_final.pdf [2019, May 14].
- Gad, M., Kriza, C., Fidler, A. & Kolominsky-Rabas, P. 2016. Accessing the medical devices market in Egypt and Saudi Arabia: a systematic review of policies and regulations. *Expert Review of Medical Devices*. 13(7):683–696.
- Gebreab, S. & Wolyei, A.R. 2014. *Regulatory overview: Ethiopia*. Available: www.idc-dx.org/download/file/fid/470 [2019, May 14].
- GHTF. 2007. *Summary technical documentation for demonstrating conformity to the essential principles of safety and performance of medical devices (STED)*. SG1/N011R17. Global Harmonization Task Force.
- Gottlieb, S. 2011. *How the FDA could cost you your life*. Available: <https://www.wsj.com/articles/SB10001424052970204831304576597200095602270> [2019, May 14].
- Gray, A. & Vawda, Y. 2016. Health policy and legislation. *South African Health Review*. 2016(1): 3–15.

- Greenspan, D.C. 2013. Regulation of medical devices: current status. In *An introduction to bioceramics*. L. L. Hench, Ed. [Singapore]: World Scientific. 549–560.
- Harper, S.R. 2003. *Global import regulations for pre-owned (used and refurbished) medical devices*. Washington, DC.: Office of Microelectronics, Medical Equipment, and Instrumentation, International Trade Administration/Trade Development, US Department of Commerce.
- Hoyle, D. 2017. *ISO 9000 Quality systems handbook – updated for the ISO 9001: 2015 standard: increasing the quality of an organization’s outputs*. London: Routledge.
- KEBS. 2017. *To all importers of medical devices, food supplements, medical cosmetics, herbal products and other allied healthcare borderline products* [Press release]. Available: <http://www.tecnofreight.net/wp-content/uploads/2017/06/13025840R-Final-artwork-KEBS-PPB-Advert.pdf>. [2019, May 20].
- Khan, J. 2017. *Regulation of medical devices in South Africa*. Available: <https://www.linkedin.com/pulse/regulation-medical-devices-south-africa-jesca-khan> [2019, May 14].
- Kirby, N. 2017. *A new regulatory regime for medicines comes into force in SA*. Available: <https://www.timeslive.co.za/news/2017-06-15-a-new-regulatory-br-regime-for-medicines-br-comes-into-force-in-sa/> [2019, May 14].
- Kramer, D.B., Xu, S. & Kesselheim, A.S. 2012. Regulation of medical devices in the United States and European Union. *The New England Journal of Medicine*. 366 (9): 848–855.
- Lamph, S. 2012. Regulation of medical devices outside the European Union. *Journal of the Royal Society of Medicine*. 105(1_suppl):12–21.
- Lilech, H. 2014. *Healthcare resource guide: Kenya*. Available: <https://2016.export.gov/industry/health/healthcareresourceguide/kenya084198.asp> [2019, May 14].
- Lissel, A., Ottenberg, F., Bracio, B.R., Ravizza, A., De Maria, C., Ahluwalia, A., Di Pietro, L. & Trommler, P., 2016, August. Status and solutions to medical device regulations for improving the healthcare landscape in Africa. In *2016 38th Annual International Conference of the IEEE Engineering in Medicine and Biology Society (EMBC)* 4329–4332.
- McAllister, P. & Jeswiet, J. 2003. Medical device regulation for manufacturers. *Proceedings of the Institution of Mechanical Engineers, Part H: Journal of Engineering in Medicine*. 217(6):459–467.
- McNerney, R. & Peeling, R.W. 2015. Regulatory in vitro diagnostics landscape in Africa: update on regional activities. *Clinical Infectious Diseases*. 61(suppl 3):S135–S140.
- MD24. 2015. *Registration of medical devices to the moroccan ministry of health*. Available: <http://www.sante.gov.ma/Pages/Accueil.aspx>. [2019, May 20].
- Mitra, A. 2016. *Fundamentals of quality control and improvement*. Portland, OR.: John Wiley & Sons.
- Moorthy, S. 2016. Medical devices manufacturers feel let down by budget. *The Hindu*. Available: <http://www.thehindubusinessline.com/economy/medical-devices-manufacturers-feel-let-down-by-budget/article8305435.ece> [2019, May 14].
- NAFDAC. 2005. *Guidelines for registration of imported drug products in Nigeria NAFDAC/RR/002/00*. Available: <http://digicollection.org/hss/documents/s17115e/s17115e.pdf> [2019, May 14].
- Nagel, F. 2017. *South Africa – medical devices*. Available: <https://www.export.gov/article?id=South-Africa-medical-devices> [2019, May 14].

- Ndamugoba, S. 2017. *Importation of medical drugs and medical devices to Tanzania*. Available: <https://www.abcattorneys.co.tz/importation-medical-drugs-medical-devices-tanzania/> [2019, May 14].
- Nogueira, C. 2017. *Angola – healthcare*. Available: <https://www.export.gov/apex/article2?id=AngolaHealthcare>. [2019, May 20].
- Omer, A.M. 2016. Evaluation of national drug policy in Sudan: regulatory privatisation, social welfare services and its alternatives. *Pharmaceutical and Biological Evaluations*. 2(6):271–283.
- Rugera, S.P., McNERney, R., Poon, A.K., Akimana, G., Mariki, R.F., Kajumbula, H., Kamau, E., Mpwawenimana, S. et al. 2014. Regulation of medical diagnostics and medical devices in the East African community partner states. *BMC Health Services Research*. 14(1):524.
- Samadi, F. 2015. *Regulatory requirements of medical devices in MENA countries*. Available: https://dgra.de/media/pdf/studium/masterthesis/master_samadi_f.pdf [2019, May 14].
- Schlickman, J.J. 2003. *ISO 9001: 2000 quality management system design*. London: Artech House.
- Sorenson, C. & Drummond, M. 2014. Improving medical device regulation: the United States and Europe in perspective. *The Milbank Quarterly*. 92(1):114–150.
- Suleman, S., Woliyi, A., Woldemichael, K., Tushune, K., Duchateau, L., Degroote, A., Vancauwenberghe, R., Bracke, N. et al. 2016. Pharmaceutical regulatory framework in Ethiopia: a critical evaluation of its legal basis and implementation. *Ethiopian Journal of Health Sciences*. 26(3):259–276.
- Tamura, A. & Kutsumi, H. 2014. Multiregional medical device development: regulatory perspective. *Clinical Journal of Gastroenterology*. 7(2):108–116.
- Technofreight. 2017. *Kenya: new regulation on import of medical devices and other products*. Available: <http://www.tecnofreight.net/en/kenya-new-regulation-import-of-medical-devices/> [2019, May 14].
- TFDA. 2016. *The Tanzania Food, Drugs and Cosmetics Regulations, 2015*. Dar Es Salaam: Government of Tanzania. Available: https://www.tfda.go.tz/index/sites/default/files/GN_315_REGULATIONS.pdf [2019, May 14].
- THEMA-MED. 2015. *Medical device registration in Algeria*. Available: <http://www.thema-med.com/en/medical-device-registration-algeria/> [2019, May 14].
- Thumm, M., Gaparayi, P., Goredema, W. & Tjipura, D. 2013. *Assessment of the medicines regulatory system in Angola: report. submitted to the US Agency for International Development by the Systems for Improved Access to Pharmaceuticals and Services (SIAPS) Program*. Available: <http://apps.who.int/medicinedocs/en/d/Js21700en/> [2019, May 14].
- UNFPA. 2015. *Policy and procedures for regular procurement*. Available: [https://www.unfpa.org/sites/default/files/resource-pdf/Policy and Procedures for Regular Procurement Rev_4 April 2015.pdf](https://www.unfpa.org/sites/default/files/resource-pdf/Policy_and_Procedures_for_Regular_Procurement_Rev_4_April_2015.pdf) [2019, May 14].
- US. Department of Commerce. 2006. *Medical device regulatory requirements for Egypt*. Available: [https://www.trade.gov/td/health/Egypt Medical Devices Regulatory Profile 2007.pdf](https://www.trade.gov/td/health/Egypt_Medical_Devices_Regulatory_Profile_2007.pdf) [2019, May 14].
- WHO. 2011. *First WHO global forum on medical devices: context, outcomes, and future actions*. Available: <https://apps.who.int/iris/handle/10665/70668> [2019, May 14].
- WHO. 2014. *Medical devices regulatory systems at country level: Morocco*. Available: http://www.who.int/medical_devices/countries/mar.pdf. [2019, May 14].
- WHO. 2016a. *Medical devices regulatory systems at country level – Tanzania*. Available: http://www.who.int/medical_devices/countries/regulations/tza.pdf [2019, May 14].

WHO. 2016b. *Promoting and supporting local manufacturing of quality medical products in developing countries*. Available: http://www.who.int/phi/publications/1651_phi_brochure_130515.pdf [2019, May 14].

WHO. 2017. *Global atlas of medical devices: WHO medical devices technical series*. Available: http://www.who.int/medical_devices/publications/global_atlas_meddev2017/en/ [2019, May 14].

World Bank. 2017. *Economy and growth: world development indicators*. Available: <https://data.worldbank.org/data-catalog/GDP-ranking-table> [2019, May 14].

Part 5

Situating Biomedical Engineering within the Health System

Chapter 20

Healthcare Technology Management

A. K. Oloyo, S. Nwaneri, S. Gbenle,
F. Ipinnimo, C. Mutswangwa & A.A. Osuntoki

Introduction

Technologies play a significant role in healthcare, and their effective management is crucial to the realization of quality healthcare. Healthcare technology management (HTM) is the systematic process of planning for and managing healthcare technology assets to enable the highest quality of care at the best cost. These tasks are multidisciplinary in nature and are carried out by qualified healthcare professionals, typically clinical engineers in partnership with others (Dyro, 2004). The overall goal of HTM is to ensure that the appropriate technologies are deployed to solve healthcare problems using suitable, cost effective, safe, functional equipment at minimal risk to users, patients and the environment.

This chapter provides an overview of the functions of HTM and concludes with some considerations for HTM in Africa.

Healthcare technology management functions

The HTM role includes finding ways to produce, procure and implement technology that is not only cost-effective but also complies with manufacturing, government, health and safety requirements. For healthcare facilities, this implies ensuring that the most cost-effective technology that makes the best use of the available resources is acquired (Bronzino, 1992) and managed for optimal performance to provide the health services mandated. The procurement and replacement of healthcare technologies require technology assessment for the identification of suitable equipment. Infrastructure and equipment installation projects require effective project management. Proper management of assets is required to achieve optimal utilisation of equipment. Appropriate and effective use of healthcare technologies can only be achieved if technical and medical personnel receive adequate training in operating and maintaining equipment. These main functions of HTM are described in further detail in the sections below.

Healthcare technology assessment

Healthcare technology assessment is a systematic approach to the identification of technologies that are applicable to a given health problem (Banta, 2003). It also examines the short and long-term consequences of the application of a healthcare technology (Sullivan et al., 2009).

The WHO (2014) describes healthcare technology assessment as systematic evaluation of both the direct, intended consequences and the indirect, unintended consequences of health technologies. Such evaluation informs policies and decision making regarding the use of technology in health care. Healthcare technology assessments are conducted by interdisciplinary groups through the utilization of explicit analytical frameworks that draw from a variety of approaches that include but are not limited to epidemiology and clinical and health economics (Dankó, 2014).

Healthcare technology assessments are carried out for various reasons; for example, ensuring that healthcare technologies conform to regulatory standards for quality, safety and performance, determining if the technologies comply with design and production process requirements (Vincent et al., 2015) and ensuring that they produce the desired health gain and offer value for money (WHO, 2014).

Project management

Project management is the management of temporary activities within specific duration, cost, quality and risk parameters to achieve desired objectives. Of interest to HTM are infrastructure and technology related projects. Examples include the design and construction of healthcare facilities and the installation of equipment.

The application of project management to healthcare processes and structures is important as it enables healthcare facilities to run more efficiently, the direct result being more affordable and higher quality of care to patients. Research articles have been published on the application of project management techniques in healthcare in African settings. For example, researchers in Nigeria have developed a model for minimizing project time, cost and risk based on specific constraints in an X-ray machine installation project (Nwaneri & Anyaeche, 2014). The purpose was to find the most efficient project schedule that balanced project parameters.

Asset management

Healthcare technology assets represent significant capital expenditure. The management of these valuable resources towards ensuring that healthcare technology is selected appropriately, used correctly and to maximum capacity, and lasts as long as possible, is a financial imperative (Gaylin et al., 2011) as healthcare technologies are important and integral components of the healthcare service delivery system. Quality healthcare services can only be provided when these technologies are in good working condition to provide a fully functional and operational environment (Erasmus, Poluta & Weeks, 2012). Thus, the effective management of healthcare technology contributes to increased health sector efficiency, and ultimately to improved health outcomes and to a sustainable health service.

Healthcare technology asset management is implemented through a coordinated set of practices and procedures. Monitoring and understanding the lifecycle of healthcare technologies allow management to forecast when to introduce a new service or product to achieve the delivery of effective and transformative healthcare. Effective asset management ensures that healthcare technology equipment is subjected to rigorous safety and performance testing prior to initial clinical use, after repair, as well as routinely according to a schedule. One of the essential instruments used in the management of healthcare technology is an asset register, which provides up-to-date records on the physical location of the device, the actual state of the device, i.e. whether it is functional or not, and the availability of spare parts.

Asset management also includes the responsibility of deciding how best to maintain a healthcare facility's equipment. This can be in the form of in-house maintenance, utilisation of vendor or manufacturer services on a contractual or an as-needed basis, and/or through maintenance insurance (Bronzino, 1992). It is assumed that responsible personnel are equipped with the relevant management skills and technical expertise that allow them to determine the optimal lifespan of health technologies and manage the replacement and upgrading of equipment.

Technical education and training

Effective HTM requires that users of medical equipment are adequately trained in, and informed about potential risks associated with, the use of healthcare technology; thus users should receive periodic operator training in addition to their initial training on newly acquired or unfamiliar equipment; this may be from in-house departments or outsourced service providers (Bronzino, 1992).

Healthcare technology management in Africa

A discrepancy in the coverage of essential health care services is especially evident between developing and developed countries, particularly in the development and management of, and access to, healthcare technology (Erasmus, Poluta & Weeks, 2012). Availability, geographical access, acceptability and affordability are some of the barriers that affect developing and low income countries (Jacobs et al., 2011) and hamper healthcare technology implementation, utilisation and innovation. The poor and marginalized in these countries are even less likely to receive effective healthcare than the better off who have the alternative of engaging in medical tourism (O'Donnell, 2007). This is in stark contrast to sustainable development goal number 3 (SDG3) of good health and well-being for all at all ages (WHO, 2015).

A study on HTM governance by Hounbo et al. (2017) in Benin provides an illustration of such challenges. The authors identified many flaws inherent in Benin's HTM system and specifically cited high prices paid by the government for health technologies.

They also identified other challenges such as insufficient staff to manage equipment and monitor supplier prices, unavailability of spare parts, lack of maintenance budgets, and unequal distribution of equipment across health care facilities. The majority of stakeholders interviewed in the study believed the country's HTM system was deficient in all respects. Furthermore, they found that the relevant policy makers were not forthcoming in addressing HTM problems and that a high degree of politicization influenced public sector decision-making.

Such conditions are prevalent in many African countries. The Ouagadougou Declaration signed by 46 ministers of health in Africa has proposed a framework that outlines generic interventions for addressing the health systems challenges faced by the African countries (WHO. AFRO, 2008). For health technologies, the framework proposes the development of formulae for the purpose of determining the requirements and forecasting of essential technologies and infrastructure; and the creation of transparent and accountable procurement systems.

In order to address the healthcare technology challenges of low-and-middle-income countries in Africa, the implementation of this framework requires training of biomedical equipment technicians, clinical engineers and biomedical engineers; these professionals play complementary roles in supporting effective healthcare delivery (Mohedas et al., 2015). Clinical engineers play a critical role in HTM implementation and in advancing patient care, through the application of engineering and management skills to healthcare technology (ACCE, 1992; Hossain et al., 2015) their functions include design and development of medical devices, maintenance, project management, education, safety, development of healthcare systems, and asset management (Bronzino, 2014). Biomedical equipment technicians "support, service and repair medical equipment including installation, calibration, inspection, preventative maintenance and repair of general biomedical and related technical equipment" (Mohedas et al., 2015:34).

While clinical engineers, biomedical engineering technicians and biomedical engineers may follow distinct training and career pathways, biomedical engineering degree programmes in African countries often have been introduced with the purpose of producing graduates able to satisfy the HTM needs of national health facilities, by training biomedical engineering technicians and clinical engineers. A recent survey of undergraduate engineering students in Ghana revealed that most of the students anticipated a career path related to HTM, particularly in the maintenance, procurement or sale of hospital equipment (Mohedas et al., 2015).

It is imperative for African countries to develop workable strategies to manage health technologies. A critical requirement is the presence in African hospitals of well-trained HTM personnel, who are able to assess technology needs, respond appropriately by procuring suitable technologies, and manage their implementation, utilisation and maintenance, for delivery of health services to suit population needs.

References

- ACCE. 1992. *ACCE definition*. Available: <https://accenet.org/about/Pages/ClinicalEngineer.aspx> [2019, May 14].
- Banta, D. 2003. The development of health technology assessment. *Health Policy*. 63(2):121–132.
- Bronzino, J.D. 1992. Clinical engineering: evolution of a discipline. In *Clinical engineering*. Y. David, W.W. von Maltzahn, M. R. Neuman, J. D. Bronzino, Eds. Boca Raton, FL.: CRC Press. 20–28.
- Bronzino, J.D. 2014. *Management of medical technology: a primer for clinical engineers*. Stoneham MA: Butterworth-Heinemann.
- Dankó, D. 2014. Health technology assessment in middle-income countries: recommendations for a balanced assessment system. *Journal of Market Access & Health Policy*. 2(1):3181.
- Dyro, J.F. 2004. Introduction to medical devices: utilization and service. *Clinical engineering handbook*. J.F. Dyro, Ed. Burlington, NJ.: Elsevier Academic Press. 371–372.
- Erasmus, L., Poluta, M. & Weeks, R. 2012. Integrated assessment and management of healthcare infrastructure and technology. *Innovate*. 7:22–30.
- Gaylin, D.S., Moiduddin, A., Mohamoud, S., Lundeen, K. & Kelly, J. A. 2011. Public attitudes about health information technology, and its relationship to healthcare quality, costs, and privacy. *Health Services Research*. 46(3):920–938.
- Hossain, M.A., Sharun, S., Rashid, M., Islam, M. & Ahmad, M. 2015. Necessity of clinical engineers to improve present health technology management in developing countries. *Modern Applied Science*. 9(12):220.
- Houngbo, P., Coleman, H., Zweekhorst, M., De Cock Buning, T., Medenou, D. & Bunders, J. 2017. A model for good governance of healthcare technology management in the public sector: learning from evidence-informed policy development and implementation in Benin. *PloS ONE*. 12(1): e0168842.
- Jacobs, B., Bigdeli, M., Annear, P. L. & Van Damme, W. 2011. Addressing access barriers to health services: an analytical framework for selecting appropriate interventions in low-income Asian countries. *Health Policy And Planning*. 27(4):288–300.
- Mohedas, I., Kaufmann, E.E., Daly, S.R. & Sienko, K.H. 2015. Ghanaian undergraduate biomedical engineering students' perceptions of their discipline and career opportunities. *Global Journal of Engineering Education*. 17(1):34–41.
- Nwaneri, S. & Anyaeche, C.O. 2014. An investigation of time-cost-risk trade-off in the installation of x-ray machine using response surface methodology. *Nigerian Journal of Technology*. 33(4):482–489. DOI: 10.4314/njt.v33i4.8.
- O'Donnell, O. 2007. Access to health care in developing countries: breaking down demand side barriers. *Cadernos de Saúde Pública*. 23:2820–2834.
- Sullivan, S.D., Watkins, J., Sweet, B. & Ramsey, S.D. 2009. Health technology assessment in health-care decisions in the United States. *Value in Health*. 12(s2): S39–44. DOI: 10.1111/j.1524-4733.2009.00557.x.
- Vincent, C.J., Niezen, G., O'Kane, A.A. & Stawarz, K. 2015. Can standards and regulations keep up with health technology? *JMIR mHealth and uHealth*. 3(2):e64. DOI:10.2196/mhealth.3918.
- WHO. 2014. *Health intervention and technology assessment in support of universal health coverage*. Available: <https://apps.who.int/iris/handle/10665/162870> [2019, May 14].

WHO. 2015. SDG 3: *Ensure healthy lives and promote wellbeing for all at all ages*. Available: <https://www.who.int/sdg/targets/en/> [2019, May 14].

WHO. AFRO. 2008. *The Ouagadougou declaration on primary health care and health systems in Africa: achieving better health for Africa in the new millennium*. Available: <https://www.afro.who.int/publications/ouagadougou-declaration-primary-health-care-and-health-systems-africa> [2019, May 14].

Introduction

Healthcare Technology Management (HTM) is the most prominent biomedical engineering-related activity in Zimbabwe. Little to no medical device development currently takes place, primarily due to the country's economic priorities and to limited understanding of the potential role of a local medical device industry. A strong bias of clinicians towards internationally branded and certified equipment has also had a negative impact on local development activities.

Medical technology adopted in Zimbabwe's public sector is predominantly donor driven, with equipment, systems and methods of implementation being dictated by donors. The private sector has more autonomy, but few entities can afford new equipment, and therefore refurbished equipment is a common choice. Donor funded or refurbished equipment, however, presents a technology management challenge in the form of short life cycles. Skills gaps, inadequate technical support, locally unavailable spare parts and disposal challenges also add to the difficulty in managing healthcare technology, both in the public and in the private sector.

This chapter provides an overview of HTM in Zimbabwe. The HTM role is discussed, models of HTM support and training are presented, and the role of regulatory bodies is reviewed.

The HTM role and its challenges

The anchoring professional role for HTM in Zimbabwe is that of the biomedical engineering technician (BMET).

Established clinical facilities typically employ BMETs of strong electronic and mechanical aptitude who receive on-the-job training. Everyday activities include equipment, air-conditioning, plumbing and lighting repairs, first line support for major equipment and related software systems, communication with suppliers for support, as well as assisting suppliers with installation, commissioning and decommissioning of hospital equipment. The BMET team is headed up by a more experienced technician who typically has 8 or more years of experience with general service and maintenance of the equipment. No medical device development activities take place.

In the private sector, procurement is a collaborative exercise between a more experienced technical staff member, often referred to as the chief or head BMET, and staff with financial, executive and end-user roles within the hospital. The role of the head BMET is crucial in the procurement process, and involves research and engagement of suppliers of equipment to establish technical specifications and cost, and to guide internal decision making. Part of the procurement exercise also involves workshop and conference attendance to understand product ranges and technological advances, as well as attending demonstrations by various potential suppliers, especially for new equipment.

The availability of foreign currency for procurement is key, especially for larger equipment, but is not always guaranteed. This implies an unpredictable wait time for allocation and remittance to foreign suppliers who have strict 100% payment policies prior to shipment. While technical planning remains one of the functional areas of BMETs, planning for repairs, replacements and associated down-time is unpredictable where foreign imports are concerned.

Another major procurement-related challenge faced by BMETs is that of unforeseen failure on commission. Technical manuals are often excluded from shipments as they provide a future source of income for the supplier. While this makes business sense for the supplier, the scarcity of local agents to assist with troubleshooting further increases clinical down-time. This consequently incapacitates in-house BMETs who revert to bringing in technicians from the supplier company to resolve what is sometimes discovered to be a minor technical fault.

Power supply quality and load shedding cause frequent failure of operational equipment. This escalates the cost of repairs and maintenance. Voltage fluctuations cause a myriad of electronic faults, which result in the bulk of the work carried out by BMETs being related to repair and replacement of damaged parts. Additionally, unforeseen phase rotations on the power grid cause problems for larger three-phase equipment, which relies on the correct phase sequence delivery for functionality. Facilities with reasonable cash flow invest in the installation of voltage regulators, phase correction units, and uninterruptible power supplies where possible. However, facilities without budget for such investments continue to run equipment on inconsistent and/or poor-quality power supply, shortening equipment lifespan.

Given the limited scope of work imposed on BMETs by the structural and health system challenges they face, there is heavy reliance on support services for the equipment for which the BMETs are responsible.

Models of HTM support

Two loosely defined models are observed to support the activities of the BMET, referred to here as *Outsourced Services* and *Shared Services*.

Outsourced services

Where there is a skills gap internal to a healthcare service company or clinical facility, services are contracted out to an external company. This includes both foreign and domestic services. For locally available expertise such as artisanry, architectural design, construction, power upgrades and corrections, equipment installations, computer networking and telephony configurations, local companies may be contracted for once-off major projects and/or ongoing support.

Foreign contracted services are usually manufacturer-based. One such example is the country's single private radiation therapy treatment centre, established in 2016, Oncocare Zimbabwe¹. Oncocare outsources major installations, repair, calibration and servicing of its linear accelerator through the Swedish equipment supplier, ELEKTA, which has a sizeable footprint for cancer treatment equipment in Africa. To complement the remote technical support of the manufacturer, staff operating the equipment and systems receive training on troubleshooting and correctly communicating faults for assistance from BMETs who are also manufacturer trained.

Medical facilities with foreign parent companies rely on foreign based agents of the parent company or sister companies for repairs and maintenance, unless repairs are minor and parts are locally available. Such is the case with Lancet Zimbabwe², which has no in-house trained staff and receives support from the Lancet Laboratories group. However, it is possible that with such a model, travel and accommodation costs for foreign staff may exceed repair costs. Down-time is sometimes unpredictable as several factors, such as the availability of spare parts at the supplier, transportation, and import expenses and restrictions, all affect overall down-time.

Outsourcing typically follows a needs-based approach. Alternatively, annual maintenance contracts (AMCs) and/or service level agreements (SLAs) are employed. These routes are often reserved for preventative maintenance of more complex equipment or services and training of first line support personnel where available. In other cases, such contracts are used to secure a priority response for major faults.

More established clinical practices have such agreements with South African manufacturers and suppliers such as TECMED Africa as well as South African satellite offices of foreign companies. Traditional medical equipment giants in the industry also offer and strongly encourage such

¹ Oncocare Zimbabwe Cancer Treatment Centre, 1 Walmer Drive, Harare, Zimbabwe, <http://oncocare.co.zw/>

² Lancet Clinical Laboratories Zimbabwe, www.lancet.co.zw

agreements. However, challenges presented by the shortage of US dollars in the economy attract tighter terms of agreement, such as 100% payment prior to dispatch of skilled personnel.

Strong commercial objectives of the private sector compel agreements that ensure maximal use of assets and adequate support. A generally sound appreciation of AMCs and/or SLAs for fields using complex, high-valued equipment can therefore be argued for the private sector. This is seen at oncology, radiology and pathology service centres across the country, whose business is highly dependent on uptime of equipment and related systems. Relationships between clients and manufacturers allow for a degree of training of resident BMETs on an ongoing basis.

Contracts established at time of sale ensure maximum up-time and safe operation of equipment. A common strategy employed by healthcare facilities, however, is to wait out a warranty period before drafting and signing contracts of agreement. Such contracts outside the warranty period can be costly, with the result that some facilities take on the risk of running without necessary measures for quality assurance, maintenance and repair, which impacts on service delivery when equipment or systems are down.

Shared services

In the shared services model, one unit provides services to multiple facets of the healthcare facility, with the aim of consolidating business operations. This may extend to a group of healthcare facilities that share services through an established shared services centre. In addition, costs are shared between various cost centres in the healthcare enterprise or group of facilities. Typical services that can be shared include human resources management, information technology, security, procurement, logistics and legal services. Typing pools, which are a common establishment in various clinical entities for the generation of patient reports, may also be a shared service.

The challenge presented by this model, is striking a balance between priority response, efficient use of skilled labour, and cost containment. Where efficient systems are in place in healthcare facilities with more experienced technical staff, the mean time between failures can be so long that it may not justify full-time employment of staff within one company. The skills-to-equipment ratio therefore needs to be taken into consideration.

Training

Formal BMET training methods and curricula are increasingly being introduced in Zimbabwe. In-service training is available and academic programmes are emerging.

In-service training is typically conducted by more senior technical personnel. Technicians with instrumentation, information technology, telecommunications, and electrical or electronic engineering qualifications are typically recruited. Activity towards device development is limited, as technicians spend years in training to bridge the gap between engineering/information technology and medicine.

Manufacturer-based training is offered by suppliers and/or manufacturers of various technologies at a cost to the company. Levels of training vary depending on the technical competence of the resident technicians and engineers. Conditions of SLAs are also considered, where training is limited to areas excluded in the agreement.

Student attachments or internships offer technical development and clinical exposure to students studying towards mechanical, electronics and instrumentation qualifications. Students are often from smaller technical training institutions. Employment prospects post-training are a large deciding factor for students considering technical attachments in a clinical setting. In general, internship programs lack structure and post-internship retention rates are low.

Academic programmes offering formal training to address the BMET training gap are being introduced, particularly at institutions with a technical bias. The Harare Institute of Technology (HIT), for example, has introduced a BTech in Biomedical Engineering, housed in the Electronics department, with strong ties to large clinical facilities in the public sector.

Regulatory bodies

The Medicines Control Agency of Zimbabwe (MCAZ) is a statutory body established by the Medicines and Allied Substances Control Act of parliament (MASCA) [Chapter 15:03]. MCAZ follows guidelines of the International Organization for Standardization (ISO) as well as WHO guidelines to ensure quality, safety and efficiency. The MCAZ Chemistry and Medical Devices Laboratories have been accredited by the Southern African Development Community Accreditation Service.

Medical device regulation in Zimbabwe is done by the medical device regulation unit housed in MCAZ. The unit's mandate is to ensure quality and market safety of medical devices. While regulations for imports and exports of medical equipment have been drafted by MCAZ, they have not yet been implemented. As there are no formal regulations as yet, government tenders reference the CE mark or FDA approval. However, MCAZ is progressing towards a tiered risk-based approach for classifying medical devices based on priority, with the initial focus being in-vitro diagnostic devices.

Due to the infectious disease burden, mainly HIV/AIDS, malaria and TB, as well as clinician protection imperatives, the primary focus of MCAZ medical device regulation since 1998 has been imported male condoms and latex gloves. Standards applied include ISO 4074 for natural rubber

latex male condoms and ISO 11193 for single-use medical examination gloves. New brands entering the country are also registered through MCAZ. Standards applied to other MCAZ activities include ISO 17025 for verifying competence of testing and calibration laboratories.

MCAZ is generally mandated with regulating all clinical trials, and with product testing as well as participating in research, documentation and policy creation, with healthcare technologies included in the scope. The body would therefore form a natural link with academic, scientific, clinical, government and industrial bodies to support the development of a medical device industry in Zimbabwe.

There is also scope for the regulatory body, in collaboration with local distributors and service providers, to play a more active role in the standardization of donor-based purchases for more focused management of healthcare technologies. The WHO has highlighted the challenges associated with donated medical devices, and offers guidelines for the planning and coordination of donations³. With thorough assessment of equipment and regulation of donation protocols, Zimbabwe and other African countries may be able to mitigate the problem of inheriting equipment with a short life-cycle and unpredictable operational safety.

Radiation protection

The Radiation Protection Authority of Zimbabwe (RPAZ) came about in 2014 through the Radiation Protection Act of Parliament [Chapter 15:15]. Legislation and guidelines have been formalized for ionizing radiation emitting devices.

RPAZ provides regulatory inspection to ensure compliance of radiation sources to legal guidelines and provides dosimeter services to all personnel exposed to ionizing radiation. Licensing of radiation services is also provided, authorizing protection and safe use of radiation sources based on Section 4 of the Radiation Protection Act [Chapter 15:15].

RPAZ is one of the few bodies to have conducted thorough needs assessment for ionizing radiation equipment across Zimbabwe, from which standards were developed for accreditation, installation and training as well as company registrations.

Although RPAZ is a well-established regulatory authority, there is still room for tighter regulation towards calibration and annual maintenance of equipment. This would improve HTM repair and maintenance standards of radiation equipment, as would partnerships between RPAZ, MCAZ and suitably identified research and training institutions.

³ “Medical device donations: considerations for solicitation and provision” available at http://www.who.int/medical_devices/management_use/manage_donations/en/

Conclusion

At present, Zimbabwe is focused on appropriate management of healthcare technologies, while other aspects of biomedical engineering have not yet been explored. Attention to the broader field of biomedical engineering could benefit the healthcare system by addressing the context-specific health technology needs of the country. Biomedical engineering education, strategic collaboration, expansion of regulatory activities, and streamlined management of existing technologies, would contribute to the overall growth of biomedical engineering and improve the availability and implementation of medical devices.

Acknowledgements

The author would like to especially acknowledge the advisory role played by the following in the preparation of this chapter: Ms G Mahlangu, Director-General, Medicines Control Authority of Zimbabwe; Mr J Kanhenga, Utano Africa and Khula Capital Trust Investment Partner; Mr J Banga, Technical Manager, The Avenues Clinic Medical Investments; Dr T Chimhundu-Sithole, Anaesthetist; Dr S Mukonoweshuro, CEO of Ultra-Med Health Care; Eng. E Rashai, Chairperson, UZ Electrical Engineering; Dr T Marisa, Researcher, UZ Electrical Engineering; Mr S. Chikutye, Laboratory Manager, Lancet Clinical Laboratories, Zimbabwe; Dr W. Kadzatsa, Radiation Oncologist.

Chapter 22

Mobile Health for Africa

B. Malila, T.E.M. Mutsvangwa & T.S. Douglas

Introduction

Africans are faced with limited access to healthcare services, a lack of financial resources dedicated to healthcare, a shortage of skilled healthcare professionals, a shortage of medical instruments and equipment, and poorly maintained health facilities (Latif et al., 2017). Telemedicine, the use of telecommunication and information technologies to provide healthcare from a distance, is one of the strategies used to address the shortage of healthcare professionals and improve access to healthcare services in rural, remote areas and poorly resourced communities. The uptake of telemedicine in developing regions such as Africa has been hampered by poor telecommunication infrastructure, especially in rural areas where it is needed most, as well as high service costs, limited awareness among healthcare workers and the patient community, and lack of government support (Mars, 2013). The evolution of telecommunications from fixed to mobile networks has resulted in renewed interest in the provision of healthcare services using telecommunication systems.

The African continent has seen a tremendous increase in mobile subscriptions and network penetration, which is expected to reach 50% by 2020 (GSMA, 2017). Mobile technologies have the potential to bring telecommunication services into almost every household globally, a feat that was not possible with fixed telecommunication systems. Mobile technologies can overcome the hurdle of infrastructure cost that has hampered the full adoption of telemedicine. This is because access networks built using wireless technologies are much cheaper than those based on wired technologies, on which telemedicine was initially based. Furthermore, broadband wireless technologies offer improved network capacity and better quality of service.

The use of mobile networks and devices by healthcare workers and in the healthcare system (mobile health or mHealth) has changed clinical practice and has the potential to improve the public health system (Latif et al., 2017); such devices make it possible to disseminate health information, gather intelligence on disease outbreaks, perform remote diagnosis of diseases, and provide health education to healthcare professionals as well patients. The World Health Organisation defines mHealth as “medical and public health practice supported by mobile devices such as mobile phones, patient monitoring devices, personal digital assistants (PDAs) and other wireless devices” (WHO. Global Observatory for eHealth, 2011).

These devices may embed programmable sensors such as gyroscopes, cameras, microphones, touch sensitive screens, ambient light sensors, proximity sensors, accelerometers, and global positioning systems. These sensors can be used to gather behavioural and physiological information. Most manufacturers of mobile devices now offer software development kits which allow developers to create novel mHealth applications. Such applications are supporting the drive towards maintaining wellness, rather than caring for the sick. A comprehensive outline of the applications of these sensors in the medical field is given by (Latif et al., 2017). Incorporation of connectivity capabilities such as Wi-Fi and Bluetooth enable the devices to connect to external networks, thus increasing their information distribution capabilities.

The decreasing costs of internet-enabled smartphones also make mHealth a powerful platform for extending healthcare services to poor people in Africa. mHealth therefore has the potential to assist African countries towards achieving the third United Nations Sustainable Development Goal, namely achieving wellness for all at all ages by 2035 (United Nations, 2017). Several initiatives to address the health challenges in Africa using mobile technologies already exist (Latif et al., 2017). However, despite the promise of mHealth, most of the implementations have either been unscalable or unsustainable.

In this chapter, we identify the opportunities driving the adoption of mobile technologies to address healthcare challenges in Sub-Saharan Africa and discuss the hurdles that have been identified in the realisation of sustainable and scalable mHealth initiatives.

Opportunities for mHealth

There is strong evidence that millions of people in Africa suffer and eventually die from diseases for which effective treatment and prevention are possible. According to a WHO report published in 2017, 15,000 children under the age of five died every day in 2016, and children in Africa are 15 times more likely to die than those in developing countries. Diarrhoea and malaria are among the leading causes of death (WHO, 2017). mHealth has the potential to assist governments in preventing the spread of diseases and deliver quality healthcare to all citizens. This can be achieved by creating awareness through dissemination of health information to the public and health professionals, surveillance of disease outbreaks to minimise transmission, training healthcare professionals, and using remote diagnosis and treatment to increase the effectiveness of the few skilled medical practitioners. This section reviews the use of mHealth to achieve these goals.

Health education and awareness

Education is an essential component of promoting health and preventing disease. Lack of knowledge about disease prevention, detection and treatment is a contributor to morbidity and mortality (Mechael, 2009).

mHealth presents an opportunity for improving the health literacy of populations through raising disease awareness and management, as well as awareness of available interventions and treatments.

Mobile devices have proved to be an effective tool for disseminating health education information around the world (O'Donovan et al., 2015). In South Africa, the MomConnect project has successfully been used to provide health-related information to more than 1.8 million South African mothers, and is being extended to provide HIV-related information to HIV patients (Pillay, 2015). The global initiative “Malaria No More”, which has saved millions of lives among people suffering from malaria through traditional diagnosis, prevention and vaccine management, is now combining its efforts with mHealth to drive life-saving results (Potyraj, 2016).

The VAS321 project, launched in Malawi to provide maternal health information to expecting mothers, has recorded a 14% increase in knowledge about appropriate breast feeding and a 22% improvement in breastfeeding behaviour (Larsen-Cooper et al., 2016). The Grameen Foundation launched the Mobile Midwife project in Ghana in 2014. The project uses SMS and interactive voice recording to deliver information about hygiene, nutrition, malaria, and immunisation. Due to positive feedback from consumer surveys, the project was adapted for implementation in Nigeria (GSMA, 2016). A project aimed at providing HIV/AIDS awareness in Uganda resulted in a 40% increase in the number of people signing up for HIV/AIDS tests (Latif et al., 2017).

While text messaging has been successfully used for mHealth, the use of internet-based instant messaging tools on mobile phones, such as WhatsApp, is emerging. Such tools can facilitate quick teleconsultation, information sharing and decisions to start treatment (Giordano et al., 2017). In South Africa, UNICEF launched WhatsApp messaging among youths to share information about HIV/AIDS and teenage pregnancy (Tshuma, 2016). In Malawi, WhatsApp is being used to assist community health workers in mobilising health resources (Pimmer et al., 2017). WhatsApp has also been piloted for use on the MomConnect project in South Africa (Praekelt, 2017).

The shortage of doctors in Africa has resulted in some unqualified people operating as professional medical doctors. An mHealth project designed to create awareness of fake doctors has been launched in Kenya (Gicheru, 2016).

Clinical decision support

Clinical decision support systems (CDSS) are computer applications that use information, rules within information databases, and patient and clinical data to improve clinical decision-making on prevention, care, diagnostics and prescription by healthcare professionals (Musen et al., 2014). Mobile technologies are currently being developed to extend the reach of CDSS to rural and remote areas, enabling healthcare professionals to make life-saving decisions and allowing patients to make appropriate choices regarding their own healthcare.

The tools used in CDSS include computerised alerts, reminders to patients and care givers, patient-specific data reports, diagnostic support and documentation templates, among others (Bakibinga et al., 2017). In Africa, CDSS are particularly important given the shortage of healthcare workers. CDSS are currently being used for supporting patients suffering from diseases such as HIV/AIDS and diabetes, supporting maternal healthcare, and assisting community health workers with disease monitoring and ensuring treatment adherence by patients (Garten, 2016).

Several CDSS have been implemented in Sub-Saharan Africa. These include:

- OpenMRS, a system supporting personalised care for patients suffering from TB, bronchitis and hypertension, which uses an app installed on a mobile phone to collect data about a patient's disease symptoms, analyse the data and provide information to the patient on how to access healthcare services (Bediang et al., 2010);
- a system aimed at improving the management of adherence to malaria treatment in rural facilities in Kenya, which was used to send SMS messages daily to patients for six months, and resulted in a 37% improvement in adherence to treatment (Zurovac et al., 2011);
- a handheld mobile device used in South Africa to screen HIV/AIDS patients for further treatment (Marc, 2009);
- an aftercare module designed for voluntary community-based health workers to provide therapeutic counselling to people living with HIV/AIDS (Bediang et al., 2010);
- the Uganda Health Information Network (Källander et al., 2013);
- the Partnership for Maternal, New-born and Child Health in Nairobi, Kenya, which aims to strengthen the healthcare delivery system in urban informal settlements, with a focus on improving the health of pregnant women and new-born babies (Bakibinga et al., 2017);
- Moby App, an Android-based system to support health workers by providing them with information to help prevent mother-to-child HIV infection (EGPAF, 2016); and
- a CDSS to reduce the number of avoidable visits by patients to a hospital in Malawi, which allowed villagers to communicate with physicians before visiting the hospital, leading to reduced patient travel costs (Latif et al., 2017).

An image-based mHealth CDSS for diagnosis of latent tuberculosis is in development at the University of Cape Town (Dendere et al., 2017). The system, consisting of a mobile app and algorithms installed on a computer, uses a smartphone to capture 2D images of the tuberculin skin test (TST) induration and transfer them to a remote database. The size of the induration is determined using algorithms that analyse the images and provide a diameter of the induration as an output. A pilot study has shown agreement between app-based and clinician measurements of the TST response. The app, which can be used by health workers or patients themselves, has the potential to provide decision support to clinicians and reduce the need for patients to return to clinics for assessment of the TST response.

A comprehensive review of more studies on CDSS in Sub-Saharan Africa, covering maternal health, TB, malaria, HIV, hypertension and childhood illnesses is given in (Adepoju et al., 2017). The decision systems include algorithms for incorporating data, individualised alerts and reminders and one-way text messages.

Disease outbreak surveillance

Disease surveillance is the continuous scrutiny of the occurrence of diseases and health-related events, and has been recognized as an effective strategy for prevention and control of epidemic-prone diseases (Adepoju et al., 2017). In most African countries, disease surveillance and notification involves immediate notification of epidemic-prone diseases, and monthly notification of those targeted for elimination and eradication (Kebede et al., 2010). Successful surveillance requires ongoing systematic collection, curation, analysis and interpretation of data on disease occurrence, as well as cooperation by healthcare institutions in identifying outbreaks, and dissemination of information.

Many disease outbreaks in Africa have been caused by lack of, or late, reporting. Studies have shown that failure to report disease outbreaks by health workers is attributed to lack of knowledge of existing reporting networks and of diseases to be reported (Kebede et al., 2010). While most countries have implemented successful surveillance systems which include training for healthcare workers, most of the systems are still paper-based (Isere et al., 2015; Kaboré et al., 2001). The high penetration rates and increasing adoption of mobile devices in Sub-Saharan Africa has the potential to enhance the development of effective disease surveillance systems in the region. Efforts to migrate some of these systems are already underway. Some of the initiatives are summarised below.

The WHO has ongoing projects for strengthening the early warning, alert and response systems (EWARS) for disease outbreaks in South Sudan, Ethiopia and Nigeria (Wamala, 2017). The web-based system, which replaces paper-based standardized data tools, strengthens the surveillance of and response capacities to disease outbreaks. The system allows real-time information sharing when disease thresholds are exceeded. The information is shared by all stakeholders via email, SMS and voice messaging using mobile phones. Epidemiological bulletins and other information are also frequently published automatically.

The Ebola disease which broke out in seven West African countries in 2013 resulted in 25,000 infections and nearly 11,000 deaths (Sacks et al., 2015). Controlling the epidemic required community engagement, identification of contacts, monitoring of symptoms, timely lab responses, patient isolation, treatment of new infections, and decent burials. Real-time availability of data to coordinate these activities was critical.

This was accomplished by the establishment of a real-time informatics system in Guinea (Sacks et al., 2015). The system comprised a mobile application and business intelligence software, enabling health workers to trace infected individuals.

Nigeria has a well-established national disease surveillance system, the strengthening epidemic response system (SERS), which allows community health workers to detect and report disease outbreaks. To improve the performance of the system, the government migrated it to a digital mobile platform, mSERS, in March 2017. This made it possible for most of the reporting to be done using mobile phones. A report released in November 2017 showed an annual increase in reported cases of Lassa fever and cholera. This was attributed, not to increasing outbreaks compared to the previous year, but rather to the effectiveness of the mSERS system (Nigeria Centre for Disease Control, 2017).

In 2015, the government of Rwanda invested in an early warning system to strengthen the country's response to natural disasters due to climate change. This would minimize the health risks associated with natural disasters such as floods and drought (Vital Wave Consulting, 2009). The project makes use of mobile phones as a communication tool that can reach over 5 million people, out of a total country population of 11.5 million. In case of emergency, warning information is quickly shared among people in the affected areas using SMS messages.

Point-of-care diagnostic and treatment support

Healthcare facilities in developing countries tend to be located centrally in major towns, with limited facilities in rural, remote, and underserved communities, leaving them more vulnerable to treatable diseases. Low-cost point-of-care diagnostic, treatment and monitoring tools could improve the delivery of healthcare services to individuals in such settings, and efforts have been made in this direction (McNerney, 2015; Sharma et al., 2015; Ertola et al., 2016). Most of the proposed solutions address cost, portability and ease of use. A report by OpenMind identifies seven studies where low-cost devices have been proposed for disease diagnosis in poor countries (OpenMind, 2015). They include blood-based devices used for testing diabetes, malaria, E. coli, hepatitis, influenza, sickle-cell anaemia and dengue. Some of these devices can be connected to mobile phones; adding mobility and internet access to the devices. This would assist healthcare workers in providing remote diagnosis and treatment to populations with limited access to healthcare facilities. It could also give healthcare workers real-time access to remote databases. The United States Agency for International Development (USAID) has published some successful implementations of mHealth initiatives in Africa for remote diagnosis and treatment support (Levine et al., 2015).

Training health workers

In most African countries, community health workers are the first line of defence against illness (Levine et al., 2015). Effective delivery of health services requires that these workers be equipped with the appropriate knowledge. Mobile phones are being used widely in developing countries to improve the knowledge of healthcare workers. Examples include:

- The HealthWiki, an online searchable database of health information, which is accessible via a mobile device (Hesperian Health Guidelines, 2018) and allows users to browse information on a range of health topics (Levine et al., 2015);
- Learning about Living, a collaborative pilot project in Nigeria for training volunteer health workers to interact with Nigerian youth, teaching them about AIDS, sex, personal development and living skills (Garten, 2016);
- OppiaMobile, an open source interactive mobile learning platform for delivering learning content in low-resource communities with poor internet connectivity (Vintimilla-Tapia et al., 2017), which is being tested in Ethiopia to deliver Ministry of Health approved training materials to healthcare workers (Levine et al., 2015); and
- mHealth for Community-Based Family Planning, which allows healthcare workers in the Shinyanga region of Tanzania to access information using their mobile phones, and receive reminders to follow up on their patients or to confirm successful referrals to healthcare facilities (Levine et al., 2015).

Disease management

mHealth is an effective tool for providing remote monitoring services for improved disease management (GSMA, 2017). Remote diagnosis, management and intervention before acute phenomena such as heart failure can lower hospital admission and utilisation costs. Diseases such as HIV/AIDS and TB have lengthy treatment periods and require strict adherence to treatment for positive results. Treatment effectiveness in such cases can be improved by ensuring reliable drug supply and sending reminders to patients to ensure adherence to treatment, while prompt messages can be sent to care givers to intervene in case of non-compliance. Quality of care can be improved by giving care givers and patients tools to manage disabilities associated with chronic diseases. Remote collection and analysis of patient data can help improve disease management and accelerate research innovations. Finally, remote monitoring has the potential to reduce the need for hospitalisation. While remote patient monitoring initiatives in Europe and the Americas are more established than is the case in Africa (Kahn, 2010), several initiatives have been established in Africa and research into implementation is also on-going (Haas, 2016). Below are examples that have integrated other technologies with mobile applications.

A system for remote monitoring of foetal heart rate was implemented in South Western Uganda (Mugenyi et al., 2017). The system consists of a battery-powered device that uses Doppler technology to obtain foetal cardiotocographs (CTG) and connects wirelessly to an android device which displays the results and sends them to a cloud-based storage system via a mobile network. Clinicians can access the information via a password-protected website. An evaluation of the device showed that 92% of CTGs were successfully recorded and stored. The pregnant women reported liking the device, as well as high levels of comfort, system flexibility, ease of use and time-saving. Education of the participants resulted in improved correct and safe usage.

A system for remotely monitoring high blood pressure patients has been implemented in Ghana (Sarfo et al., 2016). The system consists of a pill box that records medication intake and a blood pressure monitoring device. The intake record and blood pressure readings are sent to a smartphone via Bluetooth connectivity. The smartphone, in turn, sends the information to a remote database.

Challenges for adoption of mHealth

Despite the promising opportunities for mHealth in Sub-Saharan Africa and the increasing number of pilot projects and case studies, adoption of mHealth is slow. Challenges associated with successful adoption include low health literacy, the cost of mobile devices, language and culture barriers, limited healthcare infrastructure, limited internet connectivity, lack of coordination, and other socio-economic obstacles. This section discusses some of these challenges.

Low literacy

With low levels of health literacy, an individual cannot understand consent forms, medicine labels and other healthcare information. Most countries in Sub-Saharan Africa have low general literacy rates, making it difficult for individuals to be health literate. According to a UNESCO report published in 2017, the average literacy in Sub-Saharan Africa is 75%, compared to 93% for the rest of the world (UNESCO, 2017). Low literacy impedes the impact of health education. In developed countries with high literacy rates, education campaigns to promote immunization and other preventative health services have been used effectively to improve health and prevent diseases (Nutbeam, 2000).

The WHO defines health literacy as “the cognitive and social skills which determine the motivation and ability of individuals to gain access to, understand and use information in ways which promote and maintain good health” (Kickbusch, Pelikan & Apfel, 2013). Health literacy is therefore more than the ability to read pamphlets and successfully make appointments, but being able to access health information, understand the relevant information, appraise or judge the information and apply it to make informed decisions (Kickbusch, Pelikan & Apfel, 2013; Mayagah & Wayne, 2009).

Just as low literacy is related to low health status, low health literacy contributes to overall socioeconomic disadvantage (Kickbusch, Pelikan & Apfel, 2013).

mHealth technologies have the capability to avail health information to large populations. However, if the individual cannot process the information and make sense of it, this negatively impacts the effectiveness of mHealth interventions designed to improve healthcare delivery. mHealth can therefore bring health resources to the neglected, but cannot solve the problem of health illiteracy which leads to low utilization of mHealth services (Albertain et al., 2014).

The health literacy problem could be mitigated with the development of interactive voice and video mHealth applications which would not require users to read, but would enable them to view and listen to instructions in their own language. However, such services would require high quality, low cost networks, which are only promised by next generation technologies (Latif et al., 2017).

Language and cultural barriers

The language diversity in most African countries limits the potential of mHealth projects. Most of the target populations in rural and resource-limited areas are more comfortable communicating in their own languages. mHealth projects implemented in English can potentially have limited impact or even adverse results due to misunderstanding between patients and healthcare practitioners. However, most app developers are currently making efforts to translate their mHealth apps to local languages (Pillay, 2015).

In addition to the language barrier, cultural beliefs and tradition can also have a negative impact on uptake of services. For example, a project for improving maternal health in rural pregnant women in Malawi was viewed as satanic by some of the local villagers who questioned how the system knew the mothers' exact delivery dates (Nyemba-Mudenda & Chigona, 2017). Some husbands prevented their wives from participating in the project. The cultural barrier could be mitigated by educating the communities before project implementation. However, this could result in additional project costs.

Poor health facilities and infrastructure

As evidenced in most of the studies summarised above, mHealth can provide access to healthcare services to larger proportions of society, resulting in more people being aware of their health conditions and realising the need to seek medical attention. However, most health systems in Africa suffer drug shortages, limited medical practitioners and limited healthcare facilities, and could not cope with increased demand from a more informed population. Other challenges include shortage of medical equipment and poor referral systems e.g. unreliable ambulance services.

From an mHealth project implemented in Malawi, it is reported that pregnant women preferred to deliver their babies in the comfort of their homes under supervision of community healthcare workers, rather than go to understaffed hospitals where they would sleep on the floor while waiting to deliver (Nyemba-Mudenda & Chigona, 2017).

Limited network infrastructure

Despite the hype about increasing mobile network coverage in Africa, coverage gaps still exist in many rural communities (Latif et al., 2017). According to the GSMA mobility report of 2016, 3G networks cover only 50% of the population in Africa compared to a global average of 78% (GSMA, 2016). Africa is therefore home to an uncovered population of 0.6 billion people (GSMA, 2016). The mobile coverage gap is viewed as an economic rather than a technical challenge. The coverage gaps usually exist in rural locations with low population densities and low per capita income levels. Full 3G/4G coverage is only expected in 2020 in Sub-Saharan Africa (Mzekandaba, 2015). Furthermore, infrastructure such as electricity provision and high-capacity fixed communication networks may be non-existent. The lack of fixed telecommunication infrastructure such as fibre optic cables limits access to internet services, on which mHealth services ride (Albaptain et al., 2014).

For network operators, the revenue opportunities in rural areas would be lower than in urban areas, while operational costs can be significantly higher (GSMA, 2016). These business challenges could be addressed through infrastructure sharing between mobile operators and cooperation with government in sharing the cost and risk of investing in rural and remote locations. In addition, the unknown cost-effectiveness of large-scale deployment and maintenance of mHealth projects and the management challenges which remain underestimated, threaten the success of mHealth projects (Aranda-Jan et al., 2014). Careful assessment of mHealth projects is therefore required before implementation.

Cost of mobile devices and services

Cost is one of the challenges in the implementation of mHealth projects in the developing world, including Africa. Despite the decreasing cost of mobile devices, many people in Africa may still be unable to afford a mobile phone or pay for mobile or internet services (Kaplan, 2006). Community mobile phones have been used in some mHealth projects to mitigate the shortage of devices (Nyemba-Mudenda & Chigona, 2017). However, in case of emergency, access to these shared devices can be a challenge. In very poor communities, personal health monitoring would also be unaffordable on shared devices for which access is charged by the minute.

Other mobile device requirements such as battery life negatively impact the quality of mHealth services delivered. Most mHealth applications are complex and require significant battery power.

Since many rural areas with no access to electricity rely on solar systems to charge their devices, developing power-aware applications is critical (Nyemba-Mudenda & Chigona, 2017).

Government involvement and integration with existing health systems

Some of the challenges for mHealth implementation are related to government and existing health systems. Government support is of fundamental importance for the success of mHealth projects, as their political responsibility is to create optimal conditions for implementation of the required mHealth infrastructure and regulatory frameworks. Some of the reasons why mHealth is not given priority on the political agenda include lack of evidence of scalability, lack of evidence of long-term impact on health outcomes, and the need to justify the use of public funds (Gicheru, 2016). Project scaling can be difficult in poorly organized health systems, and mHealth cannot be used as a “treatment” for poor health systems (Mechael et al., 2010).

Healthcare providers should also develop the cultural and organizational capacity required to manage mHealth information (Leon et al., 2012). Lack of these skills can result in late reporting, incomplete data collection and insufficient feedback from mHealth implementations. There must also be capacity to use the collected data. The benefits of mHealth can only be fully realised if individuals are assured of the privacy of their health information, and if governments are confident that the information is secure, and its integrity maintained. It is therefore important to develop systems and strategies for ensuring the security, integrity and privacy of health information.

Conclusion

The main drivers for mHealth in Africa include high mobile penetration, increasing mobile subscriptions and the high burden of disease. Several opportunities for implementing mHealth projects exist in providing health education and creating awareness, personalised and remote patient monitoring, disease surveillance, and building clinical decision support systems. Possible challenges to full-scale and sustainable deployment include low health literacy levels; poor network, power supply and hospital infrastructures; socio-cultural barriers; and lack of political will by governments to support mHealth projects. Most mHealth projects in Sub-Saharan Africa do not advance beyond the pilot stage. To build scalable and sustainable mHealth systems that will enable the region to meet the UN Sustainable Development Goal 3 of health and well-being for all by 2030, there is need to foster strong public-private partnerships, to develop mHealth systems that can be easily integrated into existing healthcare systems, and to develop health information systems that ensure the security, integrity and privacy of patient data.

References

- Adepoju, I., Albersen, B.J.A., De Brouwere, V., van Roosmalen, J. & Zweekhorst, M. 2017. mHealth for clinical decision-making in sub-Saharan Africa: a scoping review. *JMIR mHealth and uHealth*. 5(3): e38. DOI: 10.2196/mhealth.7185.
- Albabbain, A.F., AlMulhim, D.A., Yunus, F. & Househ, M.S. 2014. The role of mobile health in the developing world: a review of current knowledge and future trends. *Journal of Selected Areas in Health Informatics*. 4(2):10–15.
- Aranda-Jan, C.B., Mohutsiwa-Dibe, N. & Loukanova, S. 2014. Systematic review on what works, what does not work and why of implementation of mobile health (mHealth) projects in Africa. *BMC Public Health*. 14(1):188. DOI: 10.1186/1471-2458-14-188.
- Bakibinga, P., Kamande, E., Omuya, M., Ziraba, A.K. & Kyobutungi, C. 2017. The role of a decision-support smartphone application in enhancing community health volunteers' effectiveness to improve maternal and new-born outcomes in Nairobi, Kenya: quasi-experimental research protocol. *BMJ Open*. 7(7). DOI:10.1136/bmjopen-2016-014896.
- Bediang, G., Bagayoko, C.O. & Geissbuhler, A. 2010. Medical decision support systems in Africa. *Yearbook of Medical Informatics*. 47–54.
- Dendere, R., Mutsvangwa, T., Goliath, R., Rangaka, M.X., Abubakar, I. & Douglas, T.S. 2017. Measurement of skin induration size using smartphone images and photogrammetric reconstruction: pilot study. *JMIR Biomedical Engineering*, 2(1): e3. DOI: 10.2196/biomedeng.8333.
- Elizabeth Glaser Paediatric Aids Foundation. 2017. *Strengthening health systems for a sustainable HIV response in Tanzania*. Available: <http://www.pedaids.org/resource/strengthening-health-systems-for-a-sustainable-hiv-response-in-tanzania/> [2019, May 14].
- Ertola, J.P., Figueira, S., Carlsen, M., Palaniappan, U. & Rondini, K. 2016. Low-cost electrocardiogram device for preventive health care in rural populations of developing countries. *IEEE Global Humanitarian Technology Conference, 13–16 October 2016*. 646–655. DOI: 10.1109/GHTC.2016.7857347.
- Garten, M. 2016. *Compendium of mHealth projects*. *mHealth Compendium*. Available: http://www.globalproblems-globalsolutions-files.org/unf_website/assets/publications/technology/mhealth/mHealth_compendium_full.pdf [2019, May 29].
- Gicheru, C. 2016. *Dodgy doctors tool claims new successes in Kenya*. Available: <https://ijnet.org/en/blog/dodgy-doctors-tool-claims-new-successes-kenya> [2019, May 14].
- Giordano, V., Koch, H., Godoy-Santos, A., Dias Belangero, W., Esteves Santos Pires, R. & Labronici, P. et al. 2017. WhatsApp messenger as an adjunctive tool for telemedicine: an overview. *Interactive Journal of Medical Research*, 6(2):e11. DOI: 10.2196/ijmr.6214.
- GSMA. 2016. *Unlocking rural coverage: enablers for commercially sustainable mobile network expansion*. London: GSMA Intelligence.
- GSMA. 2017. *Global mobile trends*. London: GSMA Intelligence.
- Haas, S. 2016. *mHealth Compendium, special edition: reaching scale*. Available: <http://www.comminit.com/hiv-aids-africa/content/mhealth-compendium-special-edition-2016-reaching-scale> [2019, May 14].
- Hesperian Health Guidelines. 2018. *Hesperian HealthWiki*. Beckley, California. Available: <http://hesperian.org/about/projects/> [2019, May 14].

- Isere, E.E., Fatiregun, A.A. & Ajayi, I.O. 2015. An overview of disease surveillance and notification system in Nigeria and the roles of clinicians in disease outbreak prevention and control. *Nigerian Medical Journal: Journal of the Nigeria Medical Association*, 56(3):161–168. DOI: 10.4103/0300-1652.160347.
- Kaboré, A., McDonnell, S. & Perkins, B.A. 2001. *Technical guidelines for integrated disease surveillance and response in the African region*. 1-229. Harare: WHO Regional Office for Africa & World Health Organization.
- Kahn, J.G., Yang, J.S. & Kahn, J.S. 2010. 'Mobile' health needs and opportunities in developing countries. *Health Affairs*, 29(2): 252–258. DOI: 10.1377/hlthaff.2009.0965.
- Kaplan, W.A. 2006. Can the ubiquitous power of mobile phones be used to improve health outcomes in developing countries? *Globalization and Health*, 2(1):9. DOI: 10.1186/1744-8603-2-9.
- Kebede, S., Duales, S., Yokouide, A. & Alemu, W. 2010. Trends of major disease outbreaks in the African region, 2003–2007. *East African Journal of Public Health*, 7(1):20–29.
- Kickbusch, J., Franklin, A. & Agis D. 2013. *Health literacy: the solid facts*. Available: <http://www.euro.who.int/en/publications/abstracts/health-literacy.-the-solid-facts> [2019, May 14].
- Larsen-Cooper, E., Bancroft, E., Rajagopal, S., O'Toole, M. & Levin, A. 2016. Scale matters: a cost-outcome analysis of an m-health intervention in Malawi. *Telemedicine and e-Health*, 22(4):317–324. DOI: 10.1089/tmj.2015.0060.
- Latif, S., Rana, R., Qadir, J., Ali, A., Ali Imran, M. & Younis, M.S. 2017. Mobile health in the developing world: review of literature and lessons from a case study. *IEEE Access*, 5:11540-11556. DOI: 10.1109/ACCESS.2017.2710800.
- Leon, N., Schneider, H. & Daviaud E. 2012. Applying a framework for assessing the health system challenges to scaling up mHealth in South Africa. *BMC Medical Informatics and Decision Making*, 12(1):123. DOI: 10.1186/1472-6947-12-123.
- Levine, A. C., Corbacio, A., Konopka, S., Saya, U., Gilmartin C. & Paradis, J. 2015. *mHealth Compendium Volume 5*. Available: <http://www.comminit.com/usaaid/content/mhealth-compendium-volume-five> [2019, May 20].
- Mars, M. 2013. Telemedicine and advances in urban and rural healthcare delivery in Africa. *Progress in Cardiovascular Diseases*. 56(3):326–335. DOI: 10.1016/j.pcad.2013.10.006.
- Mayagah, K. & Wayne, M. 2009. Promoting health and development: closing the implementation gap. Proceedings of the conference: 7th Global Conference on Health Promotion. 26–30 October 2009. Nairobi, Kenya.
- McNerney, R. 2015. Diagnostics for developing countries. *Diagnostics*. 5(2):200–209. DOI: 10.3390/diagnostics5020200.
- Mechael, P.N. 2009. The case for mHealth in developing countries. *Innovations: Technology, Governance, Globalization*. 4(1):103–118. DOI: 10.1162/itgg.2009.4.1.103.
- Mechael, P., Batavia, H. Kaonga, N., Searle, S., Kwan, A., Goldberger, A., Fu, L. & Ossman, J. 2010. *Barriers and gaps affecting mHealth in low and middle-income countries*. (Policy White Paper). New York: Center for Global Health and Economic Development, Earth Institute, Columbia University.
- Mitchel, M., Lesh, N., Cranmer, H., Fraser, H., Haivas, I. & Wolf, K. et al. 2009 Improving care – improving access: the use of electronic decision support with aids patients in South Africa. *International Journal of Healthcare Technology and Management*. 10(3):156–168. DOI: 10.1504/IJHTM.2009.025819.
- Mugenyi, G.R., Atukunda, E.C., Ngonzi, J. Boatin, A., Wylie, B.J. & Haberer, J.E. 2017. Functionality and acceptability of a wireless foetal heart rate monitoring device in term pregnant women in rural Southwestern Uganda. *BMC Pregnancy and Childbirth*. 17(1):178. DOI: 10.1186/s12884-017-1361-1.

- Musen, M.A., Middleton, B. & Greenes, R.A. 2014. Clinical decision-support systems. In *Biomedical Informatics*. E. Shortliffe & J. Cimino, Eds. London: Springer. 643–674. DOI: 10.1007/978-1-4471-4474-8_22.
- Mzekandaba, S. 2015. *Full 3G/4G coverage in Sub-Saharan Africa only after 2020*. Available: <http://www.itwebafrica.com/networks/333-africa/234562-full-3g4g-coverage-in-sub-saharan-africa-only-after-2020> [2019, May 20].
- Nigeria Centre for Disease Control. 2017. *First report of the Nigeria Centre for Disease Control*. Available: https://ncdc.gov.ng/themes/common/docs/protocols/78_1515412191.pdf [2019, May 20].
- Nutbeam, D. 2000. Health literacy as a public health goal: a challenge for contemporary health education and communication strategies into the 21st century. *Health Promotion International*. 15: 259–267. DOI:10.1093/heapro/153.259.
- Nyemba-Mudenda, M. & Chigona, W. 2017. mHealth outcomes for pregnant mothers in Malawi: a capability perspective. *Information Technology for Development*.24(5): 245–278. DOI: 10.1080/02681102.2017.1397594.
- O'Donovan, J., Bersin, A. & O'Donovan, C. 2015. The effectiveness of mobile health (mHealth) technologies to train healthcare professionals in developing countries: a review of the literature. *BMJ Innovations*, 1(1):33–36. DOI: 10.1136/bmjinnov-2014-000013.
- OpenMind. 2015. *7 Low-cost devices for diagnosing diseases in poor countries*. Available: <https://www.bbvaopenmind.com/en/low-cost-devices-for-diagnosing-diseases-in-poor-countries/> [2019, May 20].
- Pillay, Y. 2015. *MomConnect Project*. UNICEF. Available: https://www.unicef.org/southafrica/SAF_kbs2015_4_1MomConnectHowitworkswhatitachieves.pdf [2019, May 20].
- Pimmer, C., Mhango, S., Mzumara, A. & Mbvundula, F. et al. 2017. Mobile instant messaging for rural community health workers: a case from Malawi. *Global Health Action*. 10(1):1368236. DOI: 10.1080/16549716.2017.1368236.
- Potraj, J. 2016. *mHealth Innovations: lessons from Africa's digital boom*. Available: https://health.oliverwyman.com/2016/10/mHealthInnovations_Lessons.html [2019, May 20].
- Praekelt. 2017. *Praekelt.org pilots Whatsapp for social impact on behalf of MomConnect*. Available: <https://medium.com/mobileforgood/prae-kelt-org-pilots-whatsapp-for-social-impact-19a336f5b04e>. [2019, May 20].
- Sacks, J.A., Zehe, E., Redick, C., Bah, A., Cowger, K., Camara, M. Diallo, A. & Gigo, A.N.I. 2015. Introduction of mobile health tools to support Ebola surveillance and contact tracing in Guinea. *Global Health: Science and Practice*. 3(4):646–659. DOI: 10.9745/GHSP-D-15-00207.
- Sarfo, F.S., Treiber, F., Jenkins, C., Patel, S., Gebregziabher, M., Singh, A., Sarfo-Kantanka, O. & Saulson, R. 2016. Phone-based Intervention under Nurse Guidance after Stroke (PINGS): study protocol for a randomized controlled trial. *Trials*. 17(1):436. DOI: 10.1186/s13063-016-1557-0.
- Sharma, S., Zapatero-Rodríguez, J., Estrela, P. & O'Kennedy, R. 2015. Point-of-care diagnostics in low resource settings: present status and future role of microfluidics. *Biosensors*. 5(3):577–601. DOI: 10.3390/bios5030577.
- Tshuma, S. 2016. *mHealth and young people in South Africa*. Available: https://www.unicef.org/southafrica/resources_19459.html [2019, May 20].

- UNESCO. 2017. *Literacy rates continue to rise from one generation to the next*. Available: http://uis.unesco.org/sites/default/files/documents/fs45-literacy-rates-continue-rise-generation-to-next-en-2017_0.pdf [2019, May 20].
- United Nations. 2017. *The sustainable development goals report*. Available: <https://unstats.un.org/sdgs/files/report/2018/TheSustainableDevelopmentGoalsReport2018-EN.pdf> [2019, May 20].
- Vintimilla-Tapia, P.E., Bravo-Torres, J.F., Gallegos-Segovia, P.L., Ordoñez-Morales, E.F., López-Nores, M. & Blanco-Fernández, Y. 2017. Oppia: a multi-model platform for e-learning. *IEEE XXIV International Conference on Electronics, Electrical Engineering and Computing (INTERCON)* 15–18 August 2017. Cusco, Peru. 1–4.
- Vital Wave Consulting. 2009. *mHealth for development: the opportunity of mobile technology for healthcare in the developing world*. Washington, D.C. and Berkshire, UK: UN Foundation–Vodafone Foundation Partnership.
- Wamala, C. 2017. *WHO strengthens surveillance, alert and response using an innovative electronic system in South Sudan*. Available: <https://www.afro.who.int/news/who-strengthens-surveillance-alert-and-response-using-innovative-electronic-system-south-sudan> [2019, May 20].
- WHO Global Observatory for eHealth. 2011. *mHealth new horizons for health through mobile technologies: second global survey on eHealth*. Available: <http://www.who.int/iris/handle/10665/44607> [2019, May 20].
- WHO. 2017. *Children: reducing mortality*. (Fact sheet no. 178). Available: <https://www.who.int/news-room/fact-sheets/detail/children-reducing-mortality> [2019, May 20].
- Zurovac, D., Sudoi, R.K., Akhwale, W.S., Ndiritu, M., Hamer, D.H., Rowe, A.K. & Snow, R.W. 2011. The effect of mobile phone text-message reminders on Kenyan health workers' adherence to malaria treatment guidelines: a cluster randomised trial. *Lancet* 378(9793):795–803. DOI: 10.1016/S0140-6736(11)60783-6.